

# **Study materials**

## **Physics (Class 11)**

### **Chapter 7: SYSTEM OF PARTICLES AND ROTATIONAL MOTION**

## **SKYLIMIT EDUCATION**

Doltala, Najrul Sarani, Block A, Madhyamgram,

Kolkata-700132

## 7. SYSTEM OF PARTICLES AND ROTATIONAL MOTION

### Single Correct Answer Type

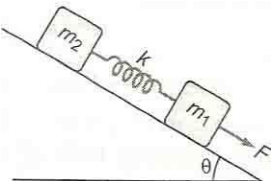
1. A small sphere of mass  $m$ , moving with a constant velocity  $v$ , hits another stationary sphere of same mass. If  $e$  be the coefficient of restitution, then ratio of velocities  $v_1$  and  $v_2$  of two spheres after collision will be  
 a)  $\frac{1-e}{1+e}$       b)  $\frac{1+e}{1-e}$       c)  $\frac{e+1}{e-1}$       d)  $\frac{e-1}{e+1}$
2. Two blocks  $m_1$  and  $m_2$  ( $m_2 > m_1$ ) are connected with a spring of force constant  $k$  and are inclined at an angle  $\theta$  with horizontal. If the system is released from rest, which one of the following statements is/are correct?
- 
- Maximum compression in the spring  
 a)  $\frac{(m_1+m_2)g \sin \theta}{k}$  if there is no friction anywhere
- There will be no compression or elongation in the spring if there is no friction anywhere  
 b)
- If  $m_1$  is smooth and  $m_2$  is rough there will be compression in the spring  
 c)
- Maximum elongation in the spring is  $\frac{(m_1-m_2)g \sin \theta}{k}$  if all the surfaces are smooth  
 d)
3. When a meteorite burns in the atmosphere, then  
 a) The momentum conservation principle is applicable to the meteorite system  
 b) The energy of meteorite remains constant  
 c) The conservation of momentum is applicable to a system consisting of meteorites, earth and air molecules  
 d) The momentum of meteorite remains constant
4. A constant torque acting on a uniform circular wheel changes its angular momentum from  $A_0$  to  $4A_0$  in 4s. The magnitude of this torque is  
 a)  $\frac{3A_0}{4}$       b)  $A_0$       c)  $4A_0$       d)  $12A_0$
5. The moment of inertia of a flywheel having kinetic energy 360 J and angular speed of  $20 \text{ rads}^{-1}$  is  
 a)  $18 \text{ kg m}^2$       b)  $1.8 \text{ kg m}^2$       c)  $2.5 \text{ kg m}^2$       d)  $9 \text{ kg m}^2$
6. If the angular momentum of a rotating body about a fixed axis is increased by 10%. Its kinetic energy will be increased by  
 a) 10%      b) 20%      c) 21%      d) 5%
7. Two discs have same mass and thickness. Their materials have densities  $d_1$  and  $d_2$ . The ratio of their moments of inertia about central axis will be  
 a)  $d_1 : d_2$       b)  $d_1 d_2 : 1$       c)  $1 : d_1 : d_2$       d)  $d_2 : d_1$

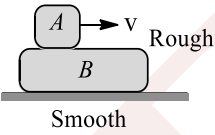

8. If the moment of inertia of a disc about an axis tangential and parallel to its surface be  $I$ , then what will be the moment of inertia about the axis tangential but perpendicular to the surface?  
 a)  $\frac{6}{5}I$                       b)  $\frac{3}{4}I$                       c)  $\frac{3}{2}I$                       d)  $\frac{5}{4}I$
9. Two bodies of 6 kg and 4 kg masses have their velocity  $5\hat{i} - 2\hat{j} + 10\hat{k}$  and  $10\hat{i} - 2\hat{j} + 5\hat{k}$  respectively. Then the velocity of their centre of mass is  
 a)  $5\hat{i} + 2\hat{j} - 8\hat{k}$               b)  $7\hat{i} + 2\hat{j} - 8\hat{k}$               c)  $7\hat{i} - 2\hat{j} + 8\hat{k}$               d)  $5\hat{i} - 2\hat{j} + 8\hat{k}$
10. Two particles of equal mass have velocities  $\mathbf{v}_1 = 4\hat{i}$  and  $\mathbf{v}_2 = 4\hat{j}$   $\text{ms}^{-1}$ . First particle has an acceleration  $\mathbf{a}_1 = (5\hat{i} + 5\hat{j}) \text{ms}^{-2}$ , while the acceleration of the other particle is zero. The centre of mass of the two particles moves in a path of  
 a) Straight line              b) Parabola              c) Circle              d) Ellipse
11. In which case application of angular velocity is useful  
 a) When a body is rotating              b) When velocity of body is in a straight line              c) When acceleration of body is in a straight line              d) None of these
12. A small block of mass  $M$  moves with velocity  $5 \text{ms}^{-1}$  towards another block of same mass  $M$  placed at a distance of 2 m on a rough horizontal surface. Coefficient of friction between the block and ground is 0.25. Collision between the two blocks is elastic, the separation between the blocks, when both of them come to rest, is ( $g = 10 \text{ms}^{-2}$ )  
 a) 3 m                      b) 4 m                      c) 2 m                      d) 1.5 m
13. Two rigid bodies  $A$  and  $B$  rotate with rotational kinetic energies  $E_A$  and  $E_B$  respectively. The moments of inertia of  $A$  and  $B$  about the axis of rotation are  $I_A$  and  $I_B$  respectively. If  $I_A = I_B/4$  and  $E_A = 100 E_B$  the ratio of angular momentum ( $L_A$ ) of  $A$  to the angular momentum ( $L_B$ ) of  $B$  is  
 a) 25                      b)  $5/4$                       c) 5                      d)  $1/4$
14. In a two block system an initial velocity  $v$  (with respect to the ground) is given to block  $A$ . Choose the correct statement.
- 

The increase in momentum of  $B$  is equal to the decrease in momentum of block  $A$
- a) The momentum of block  $A$  is not conserved.              b) The momentum of system of blocks  $A$  and  $B$  is conserved.              c) All of the above three statements.              d) None of the above
15. A solid sphere of mass  $m$  rolls down an inclined plane without slipping, starting from rest at the top of an inclined plane. The linear speed of the sphere at the bottom of the inclined plane is  $v$ . The kinetic energy of the sphere at the bottom is  
 a)  $\frac{7}{10}mv^2$                       b)  $\frac{2}{5}mv^2$                       c)  $\frac{5}{3}mv^2$                       d)  $\frac{1}{2}mv^2$
16. The moment of inertia of a solid sphere of mass  $M$  and radius  $R$  about the tangent on its surface is  
 a)  $\frac{7}{5}MR^2$                       b)  $\frac{4}{5}MR^2$                       c)  $\frac{2}{5}MR^2$                       d)  $\frac{1}{2}MR^2$
17. Torque applied on a particle is zero, then its angular momentum will be  
 a) Equal in direction              b) Equal in magnitude              c) Both (a) and (b)              d) Neither (a) nor (b)



18. Moment of inertia of a circular loop of radius  $R$  about the axis of rotation parallel to horizontal diameter at a distance  $R/2$  from it is  
 a)  $MR^2$                       b)  $\frac{1}{2}MR^2$                       c)  $2MR^2$                       d)  $\frac{3}{4}MR^2$
19. When a uniform solid sphere and a disc of the same mass and of the same radius rolls down an inclined smooth plane from rest to the same distance, then the ratio of the time taken by them is  
 a)  $15 : 14$                       b)  $15^2 : 14^2$                       c)  $\sqrt{14} : \sqrt{15}$                       d)  $14 : 15$
20. A body of mass  $M$  at rest explodes into three pieces, two of which of mass  $M/4$  each are thrown off in mutually perpendicular directions with speeds of  $3\text{ms}^{-1}$  and  $4\text{ms}^{-1}$  respectively. Then the third piece will be thrown off with a speed of  
 a)  $1.5\text{ms}^{-1}$                       b)  $2\text{ms}^{-1}$                       c)  $2.5\text{ms}^{-1}$                       d)  $3.0\text{ms}^{-1}$
21. The moment of inertia of a circular ring of mass  $1\text{kg}$  about an axis passing through its centre and perpendicular to its plane is  $4\text{kg}\cdot\text{m}^2$ . The diameter of the ring is  
 a)  $2\text{m}$                       b)  $4\text{m}$                       c)  $5\text{m}$                       d)  $6\text{m}$
22. A solid disc rolls clockwise without slipping over a horizontal path with a constant speed  $v$ . Then the magnitude of the velocities of points  $A, B$  and  $C$  (see figure) with respect to a standing observer are respectively

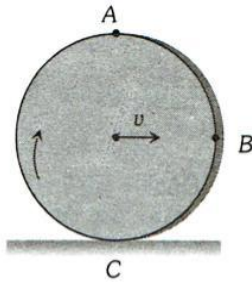

- a)  $v, v$  and  $v$                       b)  $2v, \sqrt{2v}$  and zero                      c)  $2v, 2v$  and zero                      d)  $2v, \sqrt{2v}$  and  $\sqrt{2v}$
23. What remains constant in the field of central force  
 a) Potential energy                      b) Kinetic energy                      c) Angular momentum                      d) Linear momentum
24. A  $2\text{kg}$  mass is rotating on a circular path of radius  $0.8\text{m}$  with angular velocity of  $44\text{rad/sec}$ . If radius of path becomes  $1\text{m}$ . Then the value of angular velocity will be  
 a)  $28.16\text{rad/sec}$                       b)  $35.16\text{rad/sec}$                       c)  $19.28\text{rad/sec}$                       d)  $8.12\text{rad/sec}$
25. A set of  $n$  identical cubical blocks lies at rest parallel to each other along a line on a smooth horizontal surface. The separation between the near surfaces of any two adjacent blocks is  $L$ . The block at one end is given a speed  $v$  towards the next one at time  $t = 0$ . All collision are completely elastic. Then

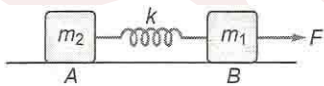

- a) The last block starts moving at time  $t = (n - 1)\frac{L}{v}$                       b) The last block starts moving at time  $t = \frac{(n-1)L}{2v}$                       c) The centre of mass of the system will have a final speed  $v$                       d) The centre of mass of the system will have a final speed  $v/n$
26. A body of mass  $3\text{kg}$  is moving with a velocity of  $4\text{ms}^{-1}$  towards right, collides head on with a body of mass  $4\text{kg}$  moving in opposite direction with a velocity of  $3\text{ms}^{-1}$ . After collision the two bodies stick together and move with a common velocity, which is  
 a) Zero                      b)  $12\text{ms}^{-1}$  towards left                      c)  $12\text{ms}^{-1}$  towards right                      d)  $\frac{12}{7}\text{ms}^{-1}$  towards left



27. Moment of inertia of a thin rod of mass  $M$  and length  $L$  about an axis passing through its centre is  $\frac{ML^2}{12}$ . Its moment of inertia about a parallel axis at a distance of  $\frac{L}{4}$  from this axis is given by  
 a)  $\frac{ML^2}{48}$                       b)  $\frac{ML^3}{48}$                       c)  $\frac{ML^2}{12}$                       d)  $\frac{7ML^2}{48}$
28. A particle of mass  $m = 5$  units is moving with a uniform speed  $v = 3\sqrt{2}$  m in the  $XOY$  plane along the line  $Y = X + 4$ . The magnitude of the angular momentum about origin is  
 a) Zero                      b) 60 unit                      c) 7.5 unit                      d)  $40\sqrt{2}$  unit
29. A torque of 30 N-m is applied on a 5 kg wheel whose moment of inertia is  $2\text{kg} - \text{m}^2$  for 10 sec. The angle covered by the wheel in 10 sec will be  
 a) 750 rad.                      b) 1500 rad.                      c) 3000 rad.                      d) 6000 rad.
30. The moment of inertia of a uniform circular disc of radius  $R$  and mass  $M$  about an axis touching the disc at its diameter and normal to the disc is  
 a)  $MR^2$                       b)  $\frac{2}{5}MR^2$                       c)  $\frac{3}{2}MR^2$                       d)  $\frac{1}{2}MR^2$
31. Two masses of 200 g and 300 g are attached to the 20 cm and 70 cm marks of a light metre rod respectively. The moment of inertia of the system about an axis passing through 50 cm mark is  
 a) 0.15 kg m<sup>2</sup>                      b) 0.03 kg m<sup>2</sup>                      c) 0.3 kg m<sup>2</sup>                      d) Zero
32. A ladder rests against a frictionless vertical wall, with its upper end 6m above the ground and the lower end 4m away from the wall. The weight of the ladder is 500 N and its C.G. at 1/3rd distance from the lower end. Wall's reaction will be, (in newton)  
 a) 111                      b) 333                      c) 222                      d) 129
33. A circular disk of moment of inertia  $I_t$  is rotating in a horizontal plane, about its symmetry axis, with a constant angular speed  $\omega_1$ . Another disk of moment of inertia  $I_b$  is dropped coaxially onto the rotating disk. Initially the second disk has zero angular speed. Eventually both the disks rotate with a constant angular speed  $\omega_1$ . The energy lost by the initially rotating disc to friction is  
 a)  $\frac{1}{2} \frac{I_b I_t}{(I_t + I_b)} \omega_i^2$                       b)  $\frac{1}{2} \frac{I_b^2}{(I_t + I_b)} \omega_i^2$                       c)  $\frac{1}{2} \frac{I_t^2}{(I_t + I_b)} \omega_i^2$                       d)  $\frac{I_b - I_t}{(I_t + I_b)} \omega_i^2$
34. Three masses of 2 kg, 4 kg and 4 kg are placed at the three points (1, 0, 0), (1, 1, 0) and (0, 1, 0) respectively. The position vector of its centre of mass is  
 a)  $\frac{3}{4}\hat{i} + \frac{4}{5}\hat{j}$                       b)  $(3\hat{i} + \hat{j})$                       c)  $\frac{2}{5}\hat{i} + \frac{4}{5}\hat{j}$                       d)  $\frac{1}{5}\hat{i} + \frac{4}{5}\hat{j}$
35. A thin wire of mass  $M$  and length  $L$  is bent to form a circular ring. The moment of inertia about its axis is  
 a)  $\frac{1}{4\pi^2} ML^2$                       b)  $\frac{1}{12} ML^2$                       c)  $\frac{1}{3\pi^2} ML^2$                       d)  $\frac{1}{\pi^2} ML^2$
36. Two bodies of masses 2 kg and 4 kg are moving with velocities 20 ms<sup>-1</sup> and 10 ms<sup>-1</sup> towards each other due to mutual gravitation attraction. What is the velocity of their centre of mass?  
 a) 5 ms<sup>-1</sup>                      b) 6 ms<sup>-1</sup>                      c) 8 ms<sup>-1</sup>                      d) Zero
37. A body is rotating with angular velocity 30 rads<sup>-1</sup>. If its kinetic energy is 360 J, then its moment of inertia is  
 a) 0.8 kgm<sup>2</sup>                      b) 0.4 kgm<sup>2</sup>                      c) 1 kgm<sup>2</sup>                      d) 1.2 kgm<sup>2</sup>
38. A round disc of moment of inertia  $I_2$  about its axis perpendicular to its plane and passing through its centre is placed over another disc of moment of inertia  $I_1$  rotating with an angular velocity  $\omega$  about the same axis. The final angular velocity of the combination of discs is  
 a)  $\frac{I_2 \omega}{I_1 + I_2}$                       b)  $\omega$                       c)  $\frac{I_1 \omega}{I_1 + I_2}$                       d)  $\frac{(I_1 + I_2) \omega}{I_1}$

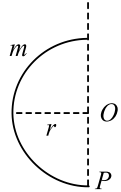

39. A solid sphere is rotating about a diameter at an angular velocity  $\omega$ . If it cools so that its radius reduces to  $\frac{1}{n}$  of its original value, its angular velocity becomes
- a)  $\frac{\omega}{n}$                       b)  $\frac{\omega}{n^2}$                       c)  $n\omega$                       d)  $n^2\omega$
40. Two particles of masses  $m_1$  and  $m_2$  in projectile motion have velocities  $\vec{v}_1$  and  $\vec{v}_2$  respectively at time  $t = 0$ . They collide at time  $t = 0$ . their velocities become  $\vec{v}_1$  and  $\vec{v}_2$  at time  $2t_0$ , while still moving in air. The value of  $|(m_1\vec{v}_1 + m_2\vec{v}_2) - (m_1\vec{v}_1 + m_2\vec{v}_2)|$  is
- a) Zero                      b)  $(m_1 + m_2)gt_0$                       c)  $2(m_1 + m_2)gt_0$                       d)  $\frac{1}{2}(m_1 + m_2)gt_0$
41. A thin wire of length  $l$  and mass  $m$  is bent in the form of semicircle. Its moment of inertia about an axis joining its free ends will be
- 
- a)  $ml^2$                       b) Zero                      c)  $ml^2/\pi^2$                       d) None of these
42. A round uniform body of radius  $R$ , mass  $M$  and moment of inertia  $I$ , rolls down (without slipping) an inclined plane making an angle  $\theta$  with the horizontal. Then its acceleration is
- a)  $\frac{g \sin \theta}{1 + I/MR^2}$                       b)  $\frac{g \sin \theta}{1 + MR^2/I}$                       c)  $\frac{g \sin \theta}{1 - I/MR^2}$                       d)  $\frac{g \sin \theta}{1 - MR^2/I}$
43. The moment of inertia of a circular disc about an axis passing through the circumference perpendicular to the plane of the disc is
- a)  $MR^2$                       b)  $\frac{3}{2}MR^2$                       c)  $\frac{MR^2}{2}$                       d)  $\frac{4}{3}MR^2$
44. A particle is projected with  $200 \text{ ms}^{-1}$ , at an angle of  $60^\circ$ . At the highest point it explodes into three particles of equal masses. One goes vertically upward with velocity  $100 \text{ ms}^{-1}$ , the second particle goes vertically downward with the same velocity as the first. Then what is the velocity of the third particle?
- a)  $120 \text{ ms}^{-1}$  with  $60^\circ$  angle                      b)  $200 \text{ ms}^{-1}$  with  $30^\circ$  angle                      c)  $50 \text{ ms}^{-1}$  vertically upwards                      d)  $300 \text{ ms}^{-1}$  horizontally
45. Two point objects of masses  $1.5 \text{ g}$  and  $2.5 \text{ g}$  respectively are at a distance of  $16 \text{ cm}$  apart, the centre of gravity is at a distance  $x$  from the object of mass  $1.5 \text{ g}$  where  $x$  is
- a)  $10 \text{ cm}$                       b)  $6 \text{ cm}$                       c)  $13 \text{ cm}$                       d)  $3 \text{ cm}$
46. The centre of mass of a system cannot change its state of motion, unless there is external force acting on it. Yet the internal force of the brakes can bring a car to rest. Then
- a) The brakes stop the wheels                      b) The friction between the brake pads and the wheel stop the car                      c) The car is stopped by the road                      d) The car is stopped by the driver pressing the pedal
47. What is moment of inertia in terms of angular momentum ( $L$ ) and kinetic energy ( $K$ )?
- a)  $\frac{L^2}{K}$                       b)  $\frac{L^2}{2K}$                       c)  $\frac{L}{2K^2}$                       d)  $\frac{L}{2K}$
48. A body  $A$  of mass  $M$  while falling vertically downwards under gravity breaks into two parts; a body  $B$  of mass  $\frac{1}{3}M$  and a body  $C$  of mass  $\frac{2}{3}M$ . The centre of mass of bodies  $B$  and  $C$  taken together shifts compared to that of body  $A$  towards



- a) Depends on height of breaking    b) Does not shift    c) Body C    d) Body B

49. A man turns on a rotating table with an angular speed  $\omega$ . He is holding two equal masses at arm's length. Without moving his arms, he just drops the two masses. How will his angular speed change

- a) It will be less than  $\omega$     b) It will be more than  $\omega$     c) It will remain equal to  $\omega$     d) May be less than, greater than or equal to  $\omega$  depending on the quantity of masses

50. A string is wound round the rim of a mounted fly wheel of mass  $20 \text{ kg}$  and radius  $20 \text{ cm}$ . A steady pull of  $25 \text{ N}$  is applied on the cord. Neglecting friction and mass of the string, the angular acceleration of the wheel is

- a)  $50 \text{ s}^{-2}$     b)  $25 \text{ s}^{-2}$     c)  $12.5 \text{ s}^{-2}$     d)  $6.25 \text{ s}^{-2}$

51. A horizontal force  $F$  is applied such that the block remains stationary then which of the following statement is false

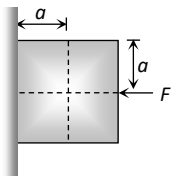

- a)  $f = mg$  [where  $f$  is the friction force]    b)  $F = N$  [where  $N$  is the normal force]    c)  $F$  will not produce torque    d)  $N$  will not produce torque

52. A solid cylinder is rolling down on an inclined plane of angle  $\theta$ . The coefficient of static friction between the plane and cylinder is  $\mu_s$ . The condition for the cylinder not to slip is

- a)  $\tan \theta \geq 3\mu_s$     b)  $\tan \theta > 3\mu_s$     c)  $\tan \theta \leq 3\mu_s$     d)  $\tan \theta < 3\mu_s$

53. A mass of  $10 \text{ kg}$  connected at the end of a rod of negligible mass is rotating in a circle of radius  $30 \text{ cm}$  with an angular velocity of  $10 \text{ rad/sec}$ . If this mass is brought to rest in  $10 \text{ sec}$  by a brake, what is the magnitude of the torque applied

- a)  $0.9 \text{ N-m}$     b)  $1.2 \text{ N-m}$     c)  $2.3 \text{ N-m}$     d)  $0.5 \text{ N-m}$

54. Two bodies having masses  $m_1$  and  $m_2$  and velocities  $\vec{u}_1$  and  $\vec{u}_2$  collide and form a composite system of  $m_1\vec{v}_1 + m_2\vec{v}_2 = 0$  ( $m_1 \neq m_2$ ). The velocity of the composite system is

- a) Zero    b)  $\vec{u}_1 + \vec{u}_2$     c)  $\vec{u}_1 - \vec{u}_2$     d)  $\frac{\vec{u}_1 + \vec{u}_2}{2}$

55. A non-uniform thin rod of length  $L$  is placed along  $X$ -axis as such its one of ends is at the origin. The linear mass density of rod is  $l = l_0x$ . The distance of centre of mass of rod from the origin is

- a)  $\frac{L}{2}$     b)  $\frac{2L}{3}$     c)  $\frac{L}{4}$     d)  $\frac{L}{5}$

56. Two negatively charges particles having charges  $e_1$  and  $e_2$  and masses  $m_1$  and  $m_2$  respectively are projected one after another into a region with equal initial velocity. The electric field  $E$  is along the  $y$ -axis, while the direction of projection makes an angle  $\alpha$  with the  $y$ -axis. If the ranges of the two particles along the  $x$ -axis are equal then one can conclude that

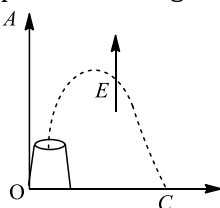

- a)  $e_1 = e_2$  and  $m_1 = l$     b)  $e_1 = e_2$  only    c)  $m_1 = m_2$  only    d)  $e_1m_1 = e_2m_2$



57. A bomb is kept stationary at a point. It suddenly explodes into two fragments of masses 1g and 3g. The total KE of the fragments is  $6.4 \times 10^4$  J. what is the KE of the smaller fragment?  
 a)  $2.5 \times 10^4$  J      b)  $3.5 \times 10^4$  J      c)  $4.8 \times 10^4$  J      d)  $5.2 \times 10^4$  J
58. The radius of gyration of a body about an axis at a distance 6 cm from its centre of mass is 10 cm. Then its radius of gyration about a parallel axis through its centre of mass will be  
 a) 80 cm      b) 8 cm      c) 0.8 cm      d) 80 cm
59. A uniform rod of mass  $m$  and length  $l$  is suspended by means of two light inextensible strings as shown in figure. Tension in one string immediately after the other string is cut is

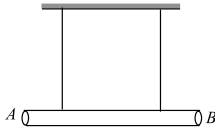

- a)  $\frac{mg}{2}$       b)  $mg$       c)  $2mg$       d)  $\frac{mg}{4}$
60. ABC is a triangular plate of uniform thickness. The sides are in the ratio shown in the figure.  $I_{AB}, I_{BC}, I_{CA}$  are the moments of inertia of the plate about AB, BC, CA respectively. Which one of the following relations is correct

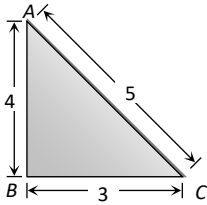

- a)  $I_{CA}$  is maximum      b)  $I_{AB} > I_{BC}$       c)  $I_{BC} > I_{AB}$       d)  $I_{AB} + I_{BC} = I_{CA}$
61. A bullet of mass 0.01 kg and travelling at a speed of  $500 \text{ms}^{-1}$  strikes a block of mass 2 kg, which is suspended by a string of length 5m. The centre of gravity of the block is found to rise a vertical distance of 0.1 m. What is the speed of the bullet after it emerges from the block?  
 a)  $580 \text{ms}^{-1}$       b)  $220 \text{ms}^{-1}$       c)  $1.4 \text{ms}^{-1}$       d)  $7.8 \text{ms}^{-1}$
62. A rigid body of mass  $m$  rotates with the angular velocity  $\omega$  about an axis at a distance ' $a$ ' from the centre of mass  $G$ . The radius of gyration about  $G$  is  $K$ . Then kinetic energy of rotation of the body about new parallel axis is  
 a)  $\frac{1}{2}mK^2\omega^2$       b)  $\frac{1}{2}ma^2\omega^2$       c)  $\frac{1}{2}m(a^2 + K^2)\omega^2$       d)  $\frac{1}{2}m(a + K^2)\omega^2$
63. Point masses 1, 2, 3 and 4 kg are lying at the point (0, 0, 0), (2, 0, 0), (0, 3, 0) and (-2, -2, 0) respectively. The moment of inertia of this system about  $x$ -axis will be  
 a) 43 kg-m<sup>2</sup>      b) 34 kg-m<sup>2</sup>      c) 27 kg-m<sup>2</sup>      d) 72 kg-m<sup>2</sup>
64. A particle is moving in the  $x$ - $y$  plane with a constant velocity along a line parallel to  $x$ -axis away from the origin. The magnitude of its angular momentum about the origin  
 a) Is zero      b) Remains constant      c) Goes on increasing      d) Goes on decreasing
65. A thin horizontal circular disc is rotating about a vertical axis passing through its centre. An insect is at rest at a point near the rim of the disc. The insect now moves along a diameter of the disc to reach other end. During the journey of the insect, the angular speed of the disc  
 a) Remains unchanged      b) Continuously decreases      c) Continuously increases      d) First increases and then decreases
66. A cord is wound round the circumference of wheel of radius  $r$ . The axis of the wheel is horizontal and moment of inertia about it is  $I$ . A weight  $mg$  is attached to the end of the cord and falls from the rest. After falling through a distance  $h$ , the angular velocity of the wheel will be



- a)  $\sqrt{\frac{2gh}{I+mr}}$       b)  $\left[\frac{2mgh}{I+mr^2}\right]^{1/2}$       c)  $\left[\frac{2mgh}{I+2mr^2}\right]^{1/2}$       d)  $\sqrt{2gh}$
67. A disc is of mass  $M$  and radius  $r$ . The moment of inertia of it about an axis tangential to its edge and in plane of the disc or parallel to its diameter is  
 a)  $\frac{5}{4}Mr^2$       b)  $\frac{Mr^2}{4}$       c)  $\frac{3}{2}Mr^2$       d)  $\frac{Mr^2}{2}$
68. A coin is of mass 4.8 kg and radius one metre rolling on a horizontal surface without sliding with angular velocity 600 rotation/min. What is total kinetic energy of the coin ?  
 a) 360 J      b)  $1440\pi^2$  J      c)  $4000\pi^2$  J      d)  $600\pi^2$  J
69. An automobile engine develops 100 kW when rotating at a speed of 1800 rev/min. What torque does it deliver  
 a) 350 N-m      b) 440 N-m      c) 531 N-m      d) 628 N-m
70. A solid sphere (mass  $2M$ ) and a thin hollow spherical shell (mass  $M$ ) both of the same size, roll down an inclined plane, then  
 a) Solid sphere will reach the bottom first  
 b) Hollow spherical shell will reach the bottom first  
 c) Both will reach at the same time  
 d) None of these
71. A cricket bat is cut at the location of its centre of mass as shown. Then  
  
 a) The two pieces will have the same mass  
 b) The bottom piece will have larger mass  
 c) The handle piece will have larger mass  
 d) Mass of handle piece is double the mass of bottom piece
72. A gas molecule of mass  $m$  strikes the wall of the container with a speed  $v$  at an angle  $\theta$  with the normal to the wall at the point of collision. The impulse of the gas molecule has a magnitude  
 a)  $3mv$       b)  $2mv \cos \theta$       c)  $mv$       d) Zero
73. Four spheres of diameter  $2a$  and mass  $M$  are placed with their centres on the four corners of a square of side  $b$ . Then the moment of inertia of the system about an axis along one of the sides of the square is  
 a)  $\frac{4}{5}Ma^2 + 2Mb^2$       b)  $\frac{8}{5}Ma^2 + 2Mb^2$       c)  $\frac{8}{5}Ma^2$       d)  $\frac{4}{5}Ma^2 + 4Mb^2$
74. A sphere and a hollow cylinder roll without slipping down two separate inclined planes and travel the same distance in the same time. If the angle of the plane down which the sphere rolls is  $30^\circ$ . The angle of the other plane is  
 a)  $60^\circ$       b)  $53^\circ$       c)  $37^\circ$       d)  $45^\circ$
75. A spherical shell has mass  $M$  and radius  $R$ . Moment of inertia about its diameter will be  
 a)  $\frac{2}{5}MR^2$       b)  $\frac{2}{3}MR^2$       c)  $\frac{1}{2}MR^2$       d)  $MR^2$
76. The radius of gyration of a disc of mass 50 g and radius 2.5 cm, about an axis passing through its centre of gravity and perpendicular to the plane, is  
 a) 0.52 cm      b) 1.76 cm      c) 3.54 cm      d) 6.54 cm
77. When two blocks A and B coupled by a spring on a frictionless table are stretched and the released, then  
 a) Kinetic energy of body at any instant after releasing is  
 b) Kinetic energy of body at any instant may or may not be  
 c)  $\frac{\text{KE of B}}{\text{KE of A}} = \frac{\text{mass of B}}{\text{mass of A}}$  when spring is massless  
 d) Both (b) and (c) is correct



- inversely proportional to their masses      inversely proportional to their masses
78. Two spheres of equal masses, one of which is a thin spherical shell and the other a solid, have the same moment of inertia about their respective diameters. The ratio of their radii will be  
a) 5:7      b) 3:5      c)  $\sqrt{3}:\sqrt{5}$       d)  $\sqrt{3}:\sqrt{7}$
79. A man is standing at the edge of a circular plate which is rotating with a constant angular speed about a perpendicular axis passing through the centre. If the man walks towards the axis along the radius, its angular velocity  
a) Decreases      b) Remains constant      c) Increases      d) Information is incomplete
80. The moment of inertia of a circular ring about an axis passing through its centre and normal to its plane is  $200 \text{ g} \times \text{cm}^2$ . Then its moment of inertia about a diameter is  
a)  $400 \text{ g} \times \text{cm}^2$       b)  $300 \text{ g} \times \text{cm}^2$       c)  $200 \text{ g} \times \text{cm}^2$       d)  $100 \text{ g} \times \text{cm}^2$
81. A constant torque of  $1000 \text{ N-m}$ , turns a wheel of moment of inertia  $200 \text{ kg-m}^2$  about an axis through the centre. Angular velocity of the wheel after 3 s will be  
a)  $15 \text{ rad/s}$       b)  $10 \text{ rad/s}$       c)  $5 \text{ rad/s}$       d)  $1 \text{ rad/s}$
82. Two particles of masses  $1 \text{ kg}$  and  $2 \text{ kg}$  are located at  $x_1 = 0, y_1 = 0$  and  $x_2 = 1, y_2 = 0$  respectively. The centre of mass of the system is at  
a)  $x = 1, y = 2$       b)  $x = 2, y = 1$       c)  $x = \frac{1}{3}, y = \frac{2}{3}$       d)  $x = \frac{2}{3}, y = 0$
83. Two wheels A and B are mounted on the same axle. Moment of inertia of A is  $6 \text{ kgm}^2$  and it is rotating at 600 rpm when B is at rest. What is moment of inertia of B, if their combined speed is 400 rpm?  
a)  $8 \text{ kg m}^2$       b)  $4 \text{ kg m}^2$       c)  $3 \text{ kg m}^2$       d)  $5 \text{ kg m}^2$
84. Three identical rods, each of length  $x$ , are joined to form a rigid equilateral triangle. Its radius of gyration about an axis passing through a corner and perpendicular to the triangle is  
a)  $\frac{x}{\sqrt{3}}$       b)  $\frac{x}{2}$       c)  $\sqrt{\frac{3}{2}}x$       d)  $\frac{x}{\sqrt{2}}$
85. A body of mass  $m$  slides down an incline and reaches the bottom with a velocity  $v$ . If the same mass were in the form of a ring which rolls down this incline, the velocity of the ring at bottom would have been  
a)  $v$       b)  $\sqrt{2}v$       c)  $\frac{1}{\sqrt{2}}v$       d)  $\sqrt{\frac{2}{5}}v$
86. An isolated particle of mass  $m$  is moving in a horizontal plane ( $x - y$ ), along the  $x$ -axis, at a certain height above the ground. It suddenly explodes into two fragments of masses  $m/4$  and  $3m/4$ . An instant later, the smaller fragment is at  $y = +15 \text{ cm}$ . The larger fragment at the instant is at  
a)  $y = -5 \text{ cm}$       b)  $y = +20 \text{ cm}$       c)  $y = +5 \text{ cm}$       d)  $y = -20 \text{ cm}$
87. Two particles A and B initially at rest, move towards each other, under mutual force of attraction. At an instance when the speed of A is  $v$  and speed B is  $2v$ , the speed of centre of mass (CM) is  
a) Zero      b)  $v$       c)  $2.5v$       d)  $4v$
88. When a mass is rotating in a plane about a fixed point, its angular momentum is directed along  
a) A line perpendicular to the plane of rotation      b) The line making an angle of  $45^\circ$  to the plane of rotation      c) The radius      d) The tangent to the orbit



89. A pulley of radius  $2m$  is rotated about its axis by a force  $F = (20t - 5t^2)$  newton (where  $t$  is measured in seconds) applied tangentially. If the moment of inertia of the pulley about its axis of rotation is  $10kg\ m^2$ , the number of rotations made by the pulley before its direction of motion is reversed, is  
 a) Less than 3      b) More than 3 but less than 6      c) More than 6 but less than 9      d) More than 9
90. A couple produces  
 a) No motion      b) Linear and rotational motion      c) Purely rotational motion      d) Purely linear motion
91. A wheel of moment of inertia  $5 \times 10^{-3}kg - m^2$  is making 20 revolutions/sec. The torque required to stop it in 10 sec is  
 a)  $2\pi \times 10^{-2}N - m$       b)  $2\pi \times 10^2N - m$       c)  $4\pi \times 10^{-2}N - m$       d)  $4\pi \times 10^2N - m$
92. A ring starts to roll down the inclined plane of height  $h$  without slipping. The velocity with it reaches the ground is  
 a)  $\sqrt{\frac{10gh}{7}}$       b)  $\sqrt{\frac{4gh}{7}}$       c)  $\sqrt{\frac{4gh}{3}}$       d)  $\sqrt{gh}$
93. In the above question, find the angular speed at the bottom  
 a) 68 rad/sec      b) 8.5 rad/sec      c) 17 rad/sec      d) 34 rad/sec
94. A body rolls down an inclined plane. If its kinetic energy of rotation is 40% of its kinetic energy of translation, then the body is  
 a) Solid cylinder      b) Solid sphere      c) Disc      d) Ring
95. A thin hollow cylinder open at both ends:  
 (i) Sliding without rolling  
 (ii) Rolls without slipping, with the same speed  
 The ratio of kinetic energy in the two cases is  
 a) 1:1      b) 4:1      c) 1:2      d) 2:1
96. The maximum and minimum distances of a comet from the sun are  $1.4 \times 10^{12}m$  and  $6 \times 10^{10}m$  respectively. If its velocity nearest to the sun is  $7 \times 10^4ms^{-1}$ , what is the velocity in the farthest position? Assume the paths of comet in both instantaneous positions are circular  
 a)  $3 \times 10^3ms^{-1}$       b)  $5 \times 10^3ms^{-1}$       c)  $7 \times 10^3ms^{-1}$       d)  $7 \times 10^3ms^{-1}$
97. In rotational motion of a rigid body, all particles move with  
 a) Same linear & angular velocity      b) Same linear and different angular velocity      c) With different linear velocities and same angular velocities      d) With different linear velocities and different angular velocities
98. A small part of the rim of a fly wheel breaks off while it is rotating at a constant angular speed. Then its radius of gyration will  
 a) Increase      b) Decrease      c) Remain unchanged      d) Nothing definite can be said
99. The moment of inertia of a uniform circular ring, having a mass  $M$  and a radius  $R$ , about an axis tangential to the ring and perpendicular to its plane, is  
 a)  $2MR^2$       b)  $\frac{3}{2}MR^2$       c)  $\frac{1}{2}MR^2$       d)  $MR^2$
100. A particle of mass  $m$  collides with another stationary particle of mass  $M$ . If the particle  $m$  stops just after collision, the coefficient of restitution of collision is equal to  
 a) 1      b)  $\frac{m}{M}$       c)  $\frac{M - m}{M + m}$       d)  $\frac{m}{M + m}$

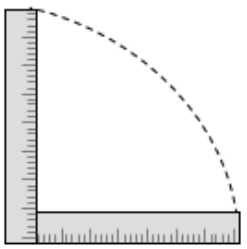

101. A spherical solid ball of 1 kg mass and radius 3 cm is rotating about an axis passing through its centre with an angular velocity of 50 radian/s. The kinetic energy of rotation is  
 a) 4500 J                      b) 90 J                      c) 910 J                      d)  $\frac{9}{20} J$
102. A thin circular ring of mass  $M$  and radius  $R$  rotates about an axis through its centre and perpendicular to its plane, with a constant angular velocity  $\omega$ . Four small spheres each of mass  $m$  (negligible radius) are kept gently to the opposite ends of two mutually perpendicular diameters of the. The new angular velocity of the ring will be  
 a)  $4\omega$                       b)  $\frac{M}{4m}\omega$                       c)  $\left(\frac{M+4m}{M}\right)\omega$                       d)  $\left(\frac{M}{M+4m}\right)\omega$
103. An athlete throws a discus from rest to a final angular velocity of 15 rad s<sup>-1</sup> in 0.270 s before releasing it. During acceleration, discus moves a circular arc of radius 0.810 m Acceleration of discus before it is released is .... ms<sup>-2</sup>  
 a) 45                      b) 182                      c) 187                      d) 192
104. A ballet dancer, dancing on a smooth floor is spinning about a vertical axis with her arms folded with an angular velocity of 20 rad/s. When she stretches her arms fully, the spinning speed decrease in 10 rad/s. If  $I$  is the initial moment of inertia of the dancer, the new moment of inertia is  
 a)  $2I$                       b)  $3I$                       c)  $I/2$                       d)  $I/3$
105. Four point masses  $P, Q, R$  and  $S$  with respective masses 1 kg, 1 kg, 2 kg form the corners of a square of side  $a$ . The center of mass of the system will be farthest from  
 a)  $P$  only                      b)  $R$  and  $S$                       c)  $R$  only                      d)  $P$  and  $Q$
106. A thin uniform circular disc of mass  $m$  and radius  $R$  is rotating in a horizontal plane about an axis passing through its centre and perpendicular to the plane with an angular velocity  $\omega$ . Another disc of same dimensions but of mass  $\frac{1}{4}m$  is placed gently on the first disc co-axially. The angular velocity of the system is  
 a)  $\sqrt{2}\omega$                       b)  $\frac{4}{5}\omega$                       c)  $\frac{3}{4}\omega$                       d)  $\frac{1}{3}\omega$
107. A solid cylinder 30 cm in diameter at the top of an inclined plane 2.0 m high is released and rolls down the incline without loss of energy due to friction. Its linear speed at the bottom is  
 a) 5.29 m/sec                      b)  $4.1 \times 10^3$  m/sec                      c) 51 m/sec                      d) 51 cm/sec
108. A metre stick is held vertically with one end on the floor and is then allowed to fall. If the end touching the floor is not allowed to slip, the other end will hit the ground with a velocity of ( $g = 9.8 \text{ m/s}^2$ )  
  
 a) 3.2 m/s                      b) 5.4 m/s                      c) 7.6 m/s                      d) 9.2 m/s
109. The centre of mass of a body  
 a) Lies always outside the body                      b) May lie within, outside on the surface of the body                      c) Lies always inside the body                      d) Lies always on the surface of the body
110. Two bodies of identical mass  $m$  are moving with constant velocity  $v$  but in the opposite directions and stick to each other, the velocity of the compound body after collision is  
 a)  $v$                       b)  $2v$                       c) Zero                      d)  $\frac{v}{2}$

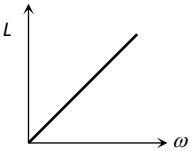
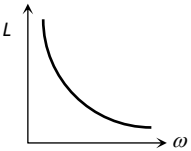
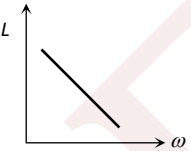
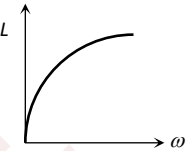
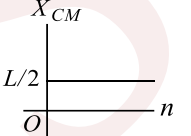
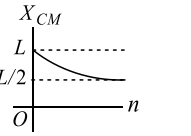
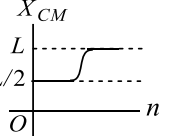
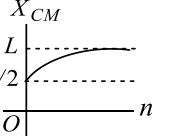

111. A solid sphere of mass 1 kg, radius 10 cm rolls down an inclined plane of height 7 m. the velocity of its centre as it reaches the ground level is  
 a) 7 m/s                      b) 10 m/s                      c) 15 m/s                      d) 20 m/s
112. Consider a two particle system with particles having masses  $m_1$  and  $m_2$ . If the first particles is pushed towards the centre of mass through a distance  $d$ , by what distance should the second particle be moved, so as to keep the centre of mass at the same position?  
 a)  $\frac{m_2}{m_1}d$                       b)  $\frac{m_1}{m_1 + m_2}$                       c)  $\frac{m_1}{m_2}d$                       d)  $d$
113. The graph between the angular momentum  $L$  and angular velocity  $\omega$  will be  
 a)                       b)                       c)                       d) 
114. A ring of radius  $r$  and mass  $m$  rotates about an axis passing through its centre and perpendicular to its plane with angular velocity  $\omega$ . Its kinetic energy is  
 a)  $mr\omega^2$                       b)  $mr\omega^2/2$                       c)  $mr^2\omega^2$                       d)  $\frac{mr^2\omega^2}{2}$
115. A bullet of mass  $m$  hits a target of mass  $M$  hanging by a string and gets embedded in it. If the block rises to a height  $h$  as a result of this collision, the velocity of the bullet before collision is  
 a)  $v = \sqrt{2gh}$                       b)  $v = \sqrt{2gh} \left(1 + \frac{m}{M}\right)$                       c)  $v = \left(1 + \frac{M}{m}\right) \sqrt{2gh}$                       d)  $v = \sqrt{2gh} \left(1 - \frac{m}{M}\right)$
116. The instantaneous angular-position of a point on a rotating wheel is given by the equation  $\theta(t) = 2t^3 - 6t^2$ . The torque on the wheel becomes zero at  
 a)  $t = 2s$                       b)  $t = 1s$                       c)  $t = 0.2 s$                       d)  $t = 0.25 s$
117. A wheel is rolling along the ground with a speed of  $2 \text{ ms}^{-1}$ . The magnitude of the velocity of the points at the extremities of the horizontal diameter of the wheel is equal to  
 a)  $2\sqrt{10} \text{ ms}^{-1}$                       b)  $2\sqrt{3} \text{ ms}^{-1}$                       c)  $2\sqrt{2} \text{ ms}^{-1}$                       d)  $2 \text{ ms}^{-1}$
118. A force  $\vec{F} = 4\hat{i} - 5\hat{j} + 3\hat{k}$  is acting a point  $\vec{r}_1 = \hat{i} + 2\hat{j} + 3\hat{k}$ . The torque acting about a point  $\vec{r}_2 = 3\hat{i} - 2\hat{j} - 3\hat{k}$  is  
 a) Zero                      b)  $42\hat{i} - 30\hat{j} + 6\hat{k}$                       c)  $42\hat{i} + 30\hat{j} + 6\hat{k}$                       d)  $42\hat{i} + 30\hat{j} - 6\hat{k}$
119. A thin rod of length ' $L$ ' lying along the  $x$ -axis with its ends at  $x = 0$  and  $x = L$ . Its linear density (mass/length) varies with  $x$  as  $k \left(\frac{x}{L}\right)^n$ , where  $n$  can be zero or any positive number. If the position  $x_{cm}$  of the centre of mass of the rod is plotted against ' $n$ ', which of the following graphs best approximates the dependence of  $x_{cm}$  on  $n$   
 a)                       b)                       c)                       d) 
120. The moment of inertia of two spheres of equal masses about their diameters are equal. If one of them is solid and other is hollow, the ratio of their radii is  
 a)  $\sqrt{3}:\sqrt{5}$                       b) 3 : 5                      c)  $\sqrt{5}:\sqrt{3}$                       d) 5 : 3
121. A circular disc  $X$  of radius  $R$  is made from an iron plate of thickness  $t$ , and another disc  $Y$  of radius  $4R$  is made from an iron plate of thickness  $t/4$ . Then the relation between the moment of inertia  $I_X$  and  $I_Y$  is  
 a)  $I_Y = 32 I_X$                       b)  $I_Y = 16 I_X$                       c)  $I_Y = I_X$                       d)  $I_Y = 64 I_X$
122. The moment of inertia of a body does not depend upon



- a) The angular velocity of the body      b) The mass of the body      c) The distribution of mass in the body      d) The axis of rotation of the body
123. The centre of mass of three particles of masses 1 kg, 2kg and 3kg is at (2, 2, 2). The position of the fourth mass of 4 kg to be places in the system as that the new centre of mass is at (0, 0, 0) is  
a) (-3,-3,-3)      b) (-3,3,-3)      c) (2,3,-3)      d) (2,-2,3)
124. A solid sphere is rolling on a frictionless surface, shown in figure with a transnational velocity  $v$  m/s. If sphere climbs up to height  $h$  then value of  $v$  should be

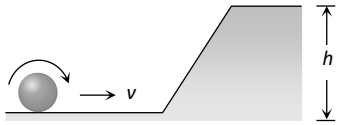

- a)  $\geq \sqrt{\frac{10}{7}gh}$       b)  $\geq \sqrt{2gh}$       c)  $2gh$       d)  $\frac{10}{7}gh$
125. A loded spring gun of mass  $M$  fires a shot of mass  $m$  with a velocity  $v$  at an angle of elevation  $\theta$ . The gun was initially at rest on a horizontal frictionless surface. After firing, the centre of mass of gun-shot system

- a) Moves with a velocity  $\frac{mv}{M}$       b) Moves with a velocity  $\frac{mv}{M \cos \theta}$  in the horizontal direction      c) Remain at rest      d) Moves with velocity  $\frac{(M-m)v}{(M+m)}$  in the horizontal direction

126. A solid sphere of mass  $M$  and radius  $R$  spins about an axis passing through its centre making 600 rpm. Its KE of rotation is

- a)  $2/5\pi^2MR$       b)  $\frac{2}{5}\pi M^2R^2$       c)  $80\pi^2MR^2$       d)  $80\pi R$

127. A metre stick of mass 400 g is pivoted at one end and displaced through an angle  $60^\circ$ . The increase in its potential energy is

- a) 2 J      b) 3 J      c) 0 J      d) 1 J

128. A small mass attached to a string rotates on a frictionless table top as shown. If the tension on the string is increased by pulling the string causing the radius of the circular motion to decrease by a factor of 2, the kinetic energy of the mass will

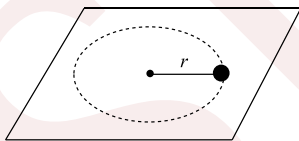

- a) Increase by a factor of 4      b) Decrease by a factor of 2      c) Remain constant      d) Increase by a factor of 2

129. Two observers are situated in different inertial reference frames. Then

- a) The momentum of a body by both observers may be same      b) The momentum of a body measured by both observers must be same      c) The kinetic energy measured by both observers must be same      d) None of the above

130. A bullet of mass  $m$  leaves a gun of mass  $M$  kept on a smooth horizontal surface. If the speed of the bullet relative to the gun is  $v$ , the recoil speed of the gun will be

- a)  $\frac{m}{M}v$       b)  $\frac{m}{M+m}v$       c)  $\frac{m}{M+m}v$       d)  $\frac{M}{m}v$



131. A rod of mass  $m$  and length  $l$  is made to stand at an angle of  $60^\circ$  with the vertical potential energy of the rod in this position is  
 a)  $mgl$                       b)  $\frac{mgl}{2}$                       c)  $\frac{mgl}{3}$                       d)  $\frac{mgl}{4}$
132. The ratio of rotational and translatory kinetic energies of a sphere is  
 a)  $\frac{2}{9}$                       b)  $\frac{2}{7}$                       c)  $\frac{2}{5}$                       d)  $\frac{7}{2}$
133. In the absence of external torque for a body revolving about any axis, the quantity that remains constant is  
 a) Kinetic energy      b) Potential energy      c) Linear momentum      d) Angular momentum
134. A uniform disk of mass  $M$  and radius  $R$  is mounted on a fixed horizontal axis. A block of mass  $m$  hangs from a mass less string that is wrapped around the rim of the disk. The magnitude of the acceleration of the falling block ( $m$ ) is  
 a)  $\frac{2M}{M+2m}g$                       b)  $\frac{2m}{M+2m}g$                       c)  $\frac{M+2m}{2M}g$                       d)  $\frac{2M+m}{2M}g$
135. A straight rod of length  $L$  has one of its ends at the origin and the other at  $x = L$ . If the mass per unit length of the rod is given by  $Ax$  where  $A$  is constant, where is its mass centre?  
 a)  $L/3$                       b)  $L/2$                       c)  $2L/3$                       d)  $3L/4$
136. A particle performs uniform circular motion with an angular momentum  $L$ , if the frequency of particles motion is doubled and its KE is halved, the angular momentum becomes  
 a)  $4L$                       b)  $0.5L$                       c)  $2L$                       d)  $0.25L$
137. The moment of momentum is called  
 a) Couple                      b) Torque                      c) Impulse                      d) Angular momentum
138. The radius of gyration of a uniform rod of length  $L$  about on axis passing through its centre of mass and perpendicular to its length is  
 a)  $L/\sqrt{12}$                       b)  $L^2/12$                       c)  $L/\sqrt{3}$                       d)  $L/\sqrt{2}$
139. A rupee coin starting from rest rolls down a distance of 1 m on an inclined plane at angle of  $30^\circ$  with the horizontal. Assuming that  $g = 9.81 \text{ ms}^{-1}$ , time taken is  
 a) 0.68 s                      b) 0.6 s                      c) 0.5 s                      d) 0.7 s
140. A solid sphere of mass  $M$ , radius  $R$  and having moment of inertia about an axis passing through the centre of mass as  $I$ , is recast into a disc of thickness  $t$ , whose moment of inertia about an axis passing through its edge and perpendicular to its plane remains  $I$ . Then, radius of the disc will be  
 a)  $\frac{2R}{\sqrt{15}}$                       b)  $R\sqrt{\frac{2}{15}}$                       c)  $\frac{4R}{\sqrt{15}}$                       d)  $\frac{R}{4}$
141. Four point masses, each of value  $m$ , are placed at the corners of a square  $ABCD$  of side  $l$ . The moment of inertia of this system about an axis passing through  $A$  and parallel to  $BD$  is  
 a)  $2ml^2$                       b)  $\sqrt{3}ml^2$                       c)  $3ml^2$                       d)  $ml^2$
142. In an elastic collision  
 a) Only KE if system is conserved      b) Only momentum is conserved      c) Both KE and momentum are conserved      d) Neither KE nor momentum is conserved
143. Two bodies  $A$  and  $B$  of definite shape (dimensions of bodies are not ignored).  $A$  is moving with speed of  $10 \text{ ms}^{-1}$  and  $B$  is in rest, collide elastically. The



- Body  $A$  comes to rest and  $B$  moves with speed of  $10\text{ms}^{-1}$
- a)  $10\text{ms}^{-1}$       b) They may move perpendicular to each other      c)  $A$  and  $B$  may come to rest      d) They must move perpendicular to each other

144. The moment of inertia of a thin uniform rod length  $L$  and mass  $M$  about an axis passing through a point at a distance of  $1/3$  from one of its ends and perpendicular to the rod is

- a)  $\frac{ML^2}{12}$       b)  $\frac{ML^2}{9}$       c)  $\frac{7ML^2}{48}$       d)  $\frac{ML^2}{48}$

145. A solid sphere, disc and solid cylinder all of the same mass and made up of same material are allowed to roll down (from rest) on inclined plane, then

- a) Solid sphere reaches the bottom first      b) Solid sphere reaches the bottom late      c) Disc will reach the bottom first      d) All of them reach the bottom at the same time

146. A system of three particles having masses  $m_1 = 1\text{ kg}$  and  $m_3 = 4\text{ kg}$  respectively is connected by two light springs. The acceleration of the three particles at any instant are  $1\text{ms}^{-2}$ ,  $2\text{ms}^{-2}$  and  $0.5\text{ms}^{-2}$  respectively directed as shown in the figure. The net external force acting on the system is

- a)  $1\text{ N}$       b)  $7\text{ N}$       c)  $3\text{ N}$       d) None of these

147. A bullet of mass  $50\text{ g}$  is fired from a gun of mass  $2\text{ kg}$ . If the total kinetic energy produced is  $2050\text{ J}$ , the kinetic energy of the bullet and the gun respectively are

- a)  $200\text{ J}, 5\text{ J}$       b)  $2000\text{ J}, 50\text{ J}$       c)  $5\text{ J}, 200\text{ J}$       d)  $50\text{ J}, 2000\text{ J}$

148. The radius of gyration of a solid sphere of radius  $r$  about a certain axis is  $r$ . The distance of this axis from the centre of the sphere is

- a)  $r$       b)  $0.5r$       c)  $\sqrt{0.6}r$       d)  $\sqrt{0.4}r$

149. The flywheel is so constructed that the entire mass of it is concentrated at its rim, because

- a) It increases the power      b) It increases the speed      c) It increases the moment of inertia      d) It saves the flywheel fan from breakage

150. In the figure (i) half of the meter scale is made of wood while the other half, of steel. The wooden part is pivoted at  $O$ . A force  $F$  is applied at the end of steel part. In figure (ii) the steel part is pivoted at  $O$  and the same force is applied at the wooden end

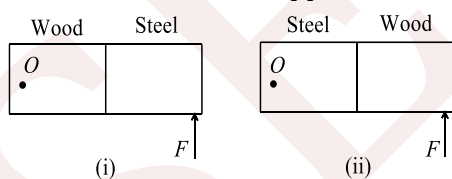

- a) More acceleration will be produced in (i)      b) More acceleration will be produced in (ii)      c) Same acceleration will be produced in both conditions      d) Information is incomplete

151. In a metallic triangular sheet  $ABC$ ,  $AB = BC = 1$ . If  $M$  is its moment of inertia about  $AC$ .

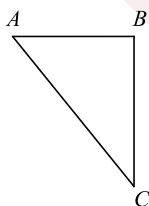

- a)  $\frac{Ml^2}{4}$       b)  $\frac{Ml^2}{12}$       c)  $\frac{Ml^2}{6}$       d)  $\frac{Ml^2}{18}$

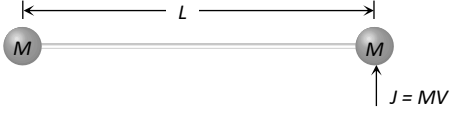

152. Moment of inertia of a ring of mass  $m = 3 \text{ gm}$  and radius  $r = 1 \text{ cm}$  about an axis passing through its edge and parallel to its natural axis is  
 a)  $10 \text{ g-cm}^2$       b)  $100 \text{ g-cm}^2$       c)  $6 \text{ g-cm}^2$       d)  $1 \text{ g-cm}^2$
153. A parallel undergoes uniform circular motion. About which point on the plane of the circle, will the angular momentum of the particle remain conserved  
 a) Centre of the circle    b) On the circumference of the circle    c) Inside the circle    d) Outside the circle
154. A wheel of mass  $8 \text{ kg}$  and radius  $40 \text{ cm}$  is rolling on a horizontal road with angular velocity of  $15 \text{ rad s}^{-1}$ . The moment of inertia of the wheel about its axis is  $0.64 \text{ kg m}^{-2}$ . Total KE of wheel is  
 a)  $288 \text{ J}$       b)  $216 \text{ J}$       c)  $72 \text{ J}$       d)  $144 \text{ J}$
155. Moment of inertia of a hollow cylinder of mass  $M$  and radius  $r$  about its own axis is  
 a)  $\frac{2}{3}Mr^2$       b)  $\frac{2}{5}Mr^2$       c)  $\frac{1}{3}Mr^2$       d)  $Mr^2$
156. Consider a body, shown in figure, consisting of two identical balls, each of mass  $M$  connected by a light rigid rod. If an impulse  $J = MV$  is imparted to the body at one of its ends, what would be its angular velocity  

  
 a)  $V/L$       b)  $2V/L$       c)  $V/3L$       d)  $V/4L$
157. A flywheel rotates with a uniform angular acceleration. Its angular velocity increases from  $20\pi \text{ rads}^{-1}$  to  $40\pi \text{ rads}^{-1}$  in  $10 \text{ s}$ . how many rotations did it make in this period?  
 a)  $80$       b)  $100$       c)  $120$       d)  $150$
158. Three identical sphere lie at rest along a line on a smooth horizontal surface. The separation between any two adjacent spheres is  $L$ . The first sphere is moved with a velocity  $u$  towards the second sphere at time  $t = 0$ . The coefficient of restitution for collision between any two blocks is  $1/3$ . Then choose the correct statement  

	The third sphere will start moving at	The third sphere will start moving at	The centre of mass of the system will have a final speed
a)	$t = \frac{5L}{2u}$	b)	$t = \frac{4L}{u}$
		c)	$u/3$
		d)	The centre of mass of the system will have a final speed $u$
159. The moment of inertia of a body about a given axis is  $2.4 \text{ kg - m}^2$ . To produce a rotational kinetic energy of  $750 \text{ J}$ , an angular acceleration of  $5 \text{ rad/s}^2$  must be applied about that axis for  
 a)  $6 \text{ sec}$       b)  $5 \text{ sec}$       c)  $4 \text{ sec}$       d)  $3 \text{ sec}$
160. Two bodies with moment of inertia  $I_1$  and  $I_2$  (such that  $I_1 > I_2$ ) have equal angular velocity. If their kinetic energy of rotation are  $E_1$  and  $E_2$  then  
 a)  $E_1 \geq E_2$       b)  $E_1 > E_2$       c)  $E_1 < E_2$       d)  $E_1 = E_2$
161. Two bodies of moment of inertia  $I_1$  and  $I_2$  ( $I_1 > I_2$ ) have equal angular momenta. If  $E_1, E_2$  are their kinetic energies of rotation, then  
 a)  $E_1 > E_2$       b)  $E_1 = E_2$       c)  $E_1 < E_2$       d) Cannot be said
162. 2 bodies of different masses of  $2 \text{ kg}$  and  $4 \text{ kg}$  are moving with velocities  $20 \text{ m/s}$  and  $10 \text{ m/s}$  towards each other due to mutual gravitational attraction. What is the velocity of their centre of mass  
 a)  $5 \text{ m/s}$       b)  $6 \text{ m/s}$       c)  $8 \text{ m/s}$       d) Zero
163. Two bodies of mass  $m$  and  $4m$  are moving with equal linear momentum. The ratio their kinetic energies is  
 a)  $1 : 4$       b)  $4 : 1$       c)  $1 : 1$       d)  $1 : 12$



164. A person standing on a rotating platform has his hands lowered. He suddenly outstretch his arms. The angular momentum  
 a) Becomes zero    b) Increases    c) Decreases    d) Remains the same
165. A body is rolling down an inclined plane. Its translational and rotational kinetic energies are equal. The body is a  
 a) Solid sphere    b) Hollow sphere    c) Solid cylinder    d) Hollow cylinder
166. Four particles of masses  $m, 2m, 3m$  and  $4m$  are arranged at the corners of a parallelogram with each inside equal to  $a$  and one of the angle between two adjacent sides is  $60^\circ$ . The parallelogram lies in the  $x$ - $y$  plane with mass  $m$  at the origin and  $4m$  on the  $x$ -axis. The centre of mass of the arrangement will be located at  
 a)  $\left(\frac{\sqrt{3}}{2}a, 0.95a\right)$     b)  $\left(0.95a, \frac{\sqrt{3}}{4}a\right)$     c)  $\left(\frac{3a}{4}, \frac{a}{2}\right)$     d)  $\left(\frac{a}{2}, \frac{3a}{4}\right)$
167. The angular momentum of a system of particles is conserved  
 a) When no external force acts upon the system    b) When no external torque acts on the system    c) When no external impulse acts upon the system    d) When axis of rotation remains same
168. A wheel of moment of inertia  $2.5 \text{ Kg-m}^2$  has an initial angular velocity of  $40 \text{ rads}^{-1}$ . A constant torque of  $10 \text{ Nm}$  acts on the wheel. The time during which the wheel is accelerated to  $60 \text{ rads}^{-1}$  is  
 a)  $4 \text{ s}$     b)  $6 \text{ s}$     c)  $5 \text{ s}$     d)  $2.5 \text{ s}$
169. A boy and a man carry a uniform rod of length  $L$ , horizontally in such a way that boy gets  $\frac{1}{4}$  th load. If the boy is at one end of the rod, the distance of the man from the other end is  
 a)  $\frac{L}{3}$     b)  $\frac{L}{4}$     c)  $\frac{2L}{3}$     d)  $\frac{3L}{4}$
170. A body is rolling down an inclined plane. If K.E. of rotation is 40% of K.E. in translatory state, then the body is a  
 a) Ring    b) Cylinder    c) Hollow ball    d) Solid ball
171. The ration of moments of inertia of circular ring and a circular disc having the same mass and radii about an axis passing through the centre and perpendicular to its plane is  
 a) 1:1    b) 2:1    c) 1:2    d) 4:1
172. Moment of inertia of rod of mass  $M$  and length  $L$  about an axis passing through a point midway between centre and end is  
 a)  $\frac{ML^2}{6}$     b)  $\frac{ML^2}{12}$     c)  $\frac{7ML^2}{24}$     d)  $\frac{7ML^2}{48}$
173. From a circular disc of radius  $R$  and mass  $9M$ , a small disc of mass  $M$  and radius  $\frac{R}{3}$  is removed concentrically. The moment of inertia of the remaining disc about an axis perpendicular to the plane of the disc and passing through its centre is  
 a)  $\frac{40}{9}MR^2$     b)  $MR^2$     c)  $4MR^2$     d)  $\frac{4}{9}MR^2$
174. The moment of inertia of a uniform ring of mass  $M$  and radius  $r$  about a tangent lying in its own plane is  
 a)  $2Mr^2$     b)  $3/2 Mr^2$     c)  $Mr^2$     d)  $1/2 Mr^2$
175. A flywheel is in the form of solid circular wheel of mass  $72 \text{ kg}$  and radius of  $0.5m$  and it takes  $70 \text{ r.p.m}$ , then the energy of revolution is  
 a)  $24 \text{ J}$     b)  $240 \text{ J}$     c)  $2.4 \text{ J}$     d)  $2400 \text{ J}$
176. Three bricks each of length  $L$  and mass  $M$  are arranged as shown from the wall. The distance of the centre of mass of the system from the wall is

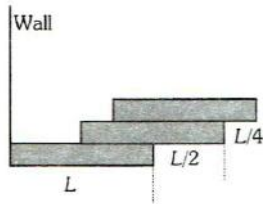



177. The distance between the carbon atom and the oxygen atom in a carbon monoxide molecule is  $1.1 \text{ \AA}$ . Given, mass of carbon atom is  $12 \text{ a.m.u.}$  and mass of oxygen atom is  $16 \text{ a.m.u.}$ , calculate the position of the centre of mass of the carbon monoxide molecule

a)  $L/4$                       b)  $L/2$                       c)  $(3/2)L$                       d)  $(11/12)L$

- a)  $6.3 \text{ \AA}$  from the carbon atom                      b)  $1 \text{ \AA}$  from the oxygen atom                      c)  $0.63 \text{ \AA}$  from the carbon atom                      d)  $0.12 \text{ \AA}$  from the oxygen atom

178. A T shaped object with dimension shown in the figure, is lying on a smooth floor. A force  $F$  is applied at the point  $P$  parallel to  $AB$ , such that the object has only the translational motion without rotation. Find the location of  $P$  with respect to  $C$ .

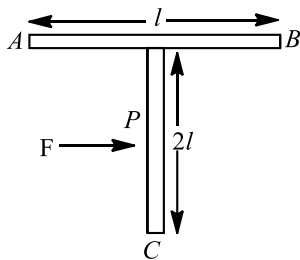

a)  $\frac{2}{3}l$                       b)  $\frac{3}{2}l$                       c)  $\frac{4}{3}l$                       d)  $l$

179. The moment of inertia of semicircular ring about an axis which is perpendicular to the plane of the ring and passes through the centre

a)  $MR^2$                       b)  $\frac{MR^2}{2}$                       c)  $\frac{MR^2}{4}$                       d) None of these

180. A system consisting of two masses connected by a massless rod lies along the  $x$ -axis. A  $0.4 \text{ kg}$  mass is at a distance  $x = 2m$  while a  $0.6 \text{ kg}$  mass is at a distance  $x = 7m$ . The  $x$ - coordinate of the centre of mass is

a)  $5m$                       b)  $3.5m$                       c)  $4.5m$                       d)  $4m$

181. A man weighing  $80 \text{ kg}$  is standing in a trolley weighing  $320 \text{ kg}$ . The trolley is resting on frictionless horizontal rails. If the man starts walking on the trolley with a speed of  $1 \text{ m/s}$ , then after  $4 \text{ sec}$  his displacement relative to the ground will be

a)  $5 \text{ m}$                       b)  $4.8 \text{ m}$                       c)  $3.2 \text{ m}$                       d)  $3.0 \text{ m}$

182. In the given figure four identical spheres of equal mass  $m$  are suspended by wires of equal length  $l_0$ , so that all spheres are almost touching to each other. If the sphere 1 is released from the horizontal position and all collisions are elastic, the velocity of sphere 4 just after collision is

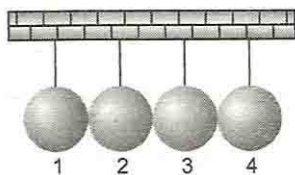

a)  $\sqrt{2gl_0}$                       b)  $\sqrt{3gl_0}$                       c)  $\sqrt{gl_0}$                       d)  $\sqrt{\frac{gl_0}{2}}$

183. A solid cylinder has mass  $M$ , length  $L$  and radius  $R$ . The moment of inertia of this cylinder about a generator is

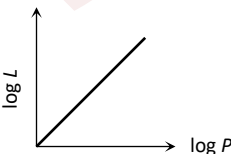
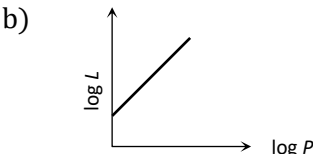
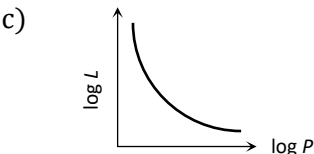
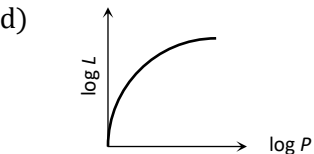

- a)  $M\left(\frac{L^2}{12} + \frac{R^2}{4}\right)$       b)  $\frac{ML^2}{4}$       c)  $\frac{1}{2}MR^2$       d)  $\frac{3}{2}MR^2$
184. A sphere rolls down on an inclined plane of inclination  $\theta$ . What is the acceleration as the sphere reaches bottom  
 a)  $\frac{5}{7}g \sin \theta$       b)  $\frac{3}{5}g \sin \theta$       c)  $\frac{2}{7}g \sin \theta$       d)  $\frac{2}{5}g \sin \theta$
185. Centre of mass of 3 particles  $10\text{ kg}$ ,  $20\text{ kg}$  and  $30\text{ kg}$  is at  $(0, 0, 0)$ . Where should a particle of mass  $40\text{ kg}$  be placed so that the combination centre of mass will be at  $(3, 3, 3)$   
 a)  $(0,0,0)$       b)  $(7.5, 7.5, 7.5)$       c)  $(1, 2, 3)$       d)  $(4, 4, 4)$
186. Moment of inertia of a disc about its own axis is  $I$ . Its moment of inertia about a tangential axis in its plane is  
 a)  $\frac{5}{2}I$       b)  $3I$       c)  $\frac{3}{2}I$       d)  $2I$
187. Turning effect is produced by  
 a) Tangential component of force      b) Radial component of force      c) Transverse component of force      d) None of these
188. A uniform cylinder has a radius  $R$  and length  $L$ . If the moment of inertia of this cylinder about an axis passing through its centre and normal to its circular face is equal to the moment of inertia of the same cylinder about an axis passing through its centre and perpendicular to its length, then  
 a)  $L = R$       b)  $L = \sqrt{3}R$       c)  $L = \frac{R}{\sqrt{3}}$       d)  $L = \sqrt{\frac{3}{2}}R$
189. Very thin ring of radius  $R$  is rotated about its centre. It's radius will  
 a) Increase      b) Decrease      c) Change depends on the material      d) None of these
190. A mass is revolving in a circle which is in the plane of paper. The direction of angular acceleration is  
 a) Upward the radius      b) Towards the radius      c) Tangential      d) At right angle to angular velocity
191. The speed of a homogeneous solid sphere after rolling down an inclined plane of vertical height  $h$ , from rest without sliding, is  
 a)  $\sqrt{\frac{10}{7}gh}$       b)  $\sqrt{gh}$       c)  $\sqrt{\frac{6}{5}gh}$       d)  $\sqrt{\frac{4}{3}gh}$
192. The moment of inertia of a circular disc of mass  $M$  and radius  $R$  about an axis passing through the center of mass is  $I_0$ . The moment of inertia of another circular disc of same mass and thickness but half the density about the same axis is  
 a)  $\frac{I_0}{8}$       b)  $\frac{I_0}{4}$       c)  $8I_0$       d)  $2I_0$
193. The curve between  $\log_e L$  and  $\log_e P$  is ( $L$  is the angular momentum and  $P$  is the linear momentum)  
 a)       b)       c)       d) 
194. A ball of mass  $m$  moving with a velocity  $u$  collides head on with another ball of mass  $m$  initially at rest. If the coefficient of restitution be  $e$  then the ratio of the final and initial velocities of the first ball is



- a)  $\frac{1-e}{1+e}$       b)  $\frac{1+e}{1-e}$       c)  $\frac{1+e}{2}$       d)  $\frac{1-e}{2}$

195. The motion of planets in the solar system is an example of conservation of  
a) Mass      b) Momentum      c) Angular momentum      d) Kinetic energy

196. Three identical spheres of mass  $M$  each are placed at the corners of an equilateral triangle of side  $2m$ . Taking one of the corner as the origin, the position vector of the centre of mass is

- a)  $\sqrt{3}(\hat{i}-\hat{j})$       b)  $\frac{\hat{i}}{\sqrt{3}}+\hat{j}$       c)  $\frac{\hat{i}+\hat{j}}{3}$       d)  $\hat{i}+\frac{\hat{j}}{\sqrt{3}}$

197. Two thin discs each of mass  $M$  and radius  $R$  are placed at either end of a rod of mass  $m$ , length  $l$  and radius  $r$ . Moment of inertia of the system about an axis passing through the centre of rod and perpendicular to its length is

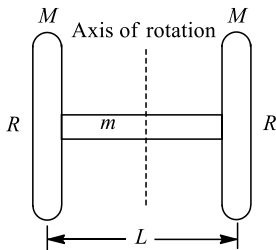

- a)  $\frac{mL^2}{12} + \frac{1}{4}MR^2 + \frac{1}{4}ML^2$       b)  $\frac{ML^2}{12} + \frac{1}{2}mR^2 + \frac{1}{2}mL^2$       c)  $\frac{1}{2}mL^2 + \frac{MR^2}{2} + \frac{ML^2}{12}$       d)  $\frac{mL^2}{12} + MR^2 + \frac{1}{2}ML^2$

198. If a cycle wheel of radius 4 m completes one revolution in two second, the acceleration of the cycle in  $\text{ms}^{-2}$  is

- a) 4      b)  $4\pi^2$       c)  $2\pi^2$       d)  $\pi^2$

199. In a rectangle  $ABCD$  ( $BC = 2AB$ ). The moment of inertia along which axes will be minimum

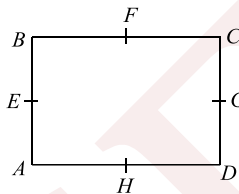

- a)  $BC$       b)  $BD$       c)  $HF$       d)  $EG$

200. A wheel having moment of inertia  $2 \text{ kg} - \text{m}^2$  about its vertical axis, rotates at the rate of 60 rpm about this axis. The torque which can stop the wheel's rotation in one minute would be

- a)  $\frac{2\pi}{15}N - m$       b)  $\frac{\pi}{12}N - m$       c)  $\frac{\pi}{15}N - m$       d)  $\frac{\pi}{18}N - m$

201. Three identical balls  $A, B$  and  $C$  are lying on a horizontal frictionless table as shown in figure. If ball  $A$  is imparted a velocity  $v$  towards  $B$  and  $C$  and the collisions are perfectly elastic, then finally

- a) Ball  $A$  comes to rest and balls  $B$  and  $C$  roll out with speed  $v/2$  each      b) Ball  $A$  and  $B$  are at rest and ball  $C$  rolls out with speed  $v$       c) All the three balls roll out with speed  $v/3$  each      d) All the three balls come to rest

202. Moment of inertia of a solid cylinder of length  $L$  and diameter  $D$  about an axis passing through its centre of gravity and perpendicular to its geometric axis is

- a)  $M\left(\frac{D^2}{4} + \frac{L^2}{12}\right)$       b)  $M\left(\frac{L^2}{16} + \frac{D^2}{8}\right)$       c)  $M\left(\frac{D^2}{4} + \frac{L^2}{6}\right)$       d)  $M\left(\frac{L^2}{12} + \frac{D^2}{16}\right)$

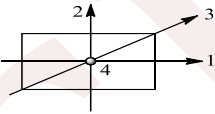

203. The M.I. of a body about the given axis is  $1.2 \text{ kg} \times \text{m}^2$  initially the body is at rest. In order to produce a rotational kinetic energy of  $1500 \text{ J}$ , an angular acceleration of  $25 \text{ rad/sec}^2$  must be applied about that axis for duration of  
 a)  $4 \text{ sec}$                       b)  $2 \text{ sec}$                       c)  $8 \text{ sec}$                       d)  $10 \text{ sec}$
204. A circular disc is to be made by using iron and aluminium, so that it acquires maximum moment of inertia about its geometrical axis. It is possible with  
 a) Iron and aluminium layers in alternate order                      b) Aluminium at interior and iron surrounding it                      c) Iron at interior and aluminium surrounding it                      d) Either (a) or (c)
205. The distance between the centres of carbon and oxygen atoms in the carbon monoxide molecule is  $1.130 \text{ \AA}$ . Locate the centre of mass of the molecule relative to the carbon atom.  
 a)  $5.428 \text{ \AA}$                       b)  $1.130 \text{ \AA}$                       c)  $0.6457 \text{ \AA}$                       d)  $0.3260 \text{ \AA}$
206. Two particles of masses  $m_1$  and  $m_2$  initially at rest start moving towards each other under their mutual force of attraction. The speed of the centre of mass at any time  $t$ , when they are at a distance  $r$  apart, is  
 a) Zero                      b)  $\left(G \frac{m_1 m_2}{r^2} \cdot \frac{1}{m_1}\right)t$                       c)  $\left(G \frac{m_1 m_2}{r^2} \cdot \frac{1}{m_2}\right)t$                       d)  $\left(G \frac{m_1 m_2}{r^2} \cdot \frac{1}{m_1 + m_2}\right)t$
207. A sphere of mass  $0.5 \text{ kg}$  and diameter  $1 \text{ m}$  rolls without sliding with a constant velocity of  $5 \text{ m/s}$ , calculate what is the ratio of the rotational  $K.E.$  to the total kinetic energy of the sphere  
 a)  $\frac{7}{10}$                       b)  $\frac{5}{7}$                       c)  $\frac{2}{7}$                       d)  $\frac{1}{2}$
208. The moment of inertia of a uniform horizontal cylinder of mass  $M$  about an axis passing through its edge and perpendicular to the axis of the cylinder when its length is 6 times its radius  $R$  is  
 a)  $\frac{39}{4}MR^2$                       b)  $\frac{39}{4}MR$                       c)  $\frac{49}{4}MR$                       d)  $\frac{49}{4}MR^2$
209. A  $1 \text{ m}$  long rod has a mass of  $0.12 \text{ kg}$ . What is the moment of inertia about an axis passing through the centre and perpendicular to the length of rod  
 a)  $0.01 \text{ kg-m}^2$                       b)  $0.001 \text{ kg-m}^2$                       c)  $1 \text{ kg-m}^2$                       d)  $10 \text{ kg-m}^2$
210. About which axis in the following figure the moment of inertia of the rectangular lamina is maximum?  
  
 a) 1                      b) 2                      c) 3                      d) 4
211. A ring starts to roll down the inclined plane of height  $h$  without slipping. The velocity with which it reaches the ground is  
 a)  $\sqrt{\frac{10gh}{7}}$                       b)  $\sqrt{\frac{4gh}{7}}$                       c)  $\sqrt{\frac{4gh}{3}}$                       d)  $\sqrt{gh}$
212. The angular momentum of particle  
 a) Is perpendicular to the plane of the surface in which it moves                      b) Along the plane of motion                      c) Inclined at any angle with the plane                      d) Has no particular direction
213. Four balls each of radius  $10 \text{ cm}$  and mass  $1 \text{ kg}$ ,  $2 \text{ kg}$ ,  $3 \text{ kg}$  and  $4 \text{ kg}$  are attached to the periphery of massless plate of radius  $1 \text{ m}$ . What is moment of inertia of the system about the centre of plate?



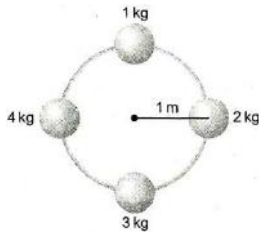

- a)  $12.04 \text{ kg-m}^2$       b)  $10.04 \text{ kg-m}^2$       c)  $11.50 \text{ kg-m}^2$       d)  $5.04 \text{ kg-m}^2$
214. A constant torque of  $1000 \text{ N-m}$  turns a wheel of moment of inertia  $200 \text{ kg-m}^2$  about an axis through its centre. Its angular velocity after  $3 \text{ sec}$  is  
a)  $1 \text{ rad/sec}$       b)  $5 \text{ rad/sec}$       c)  $10 \text{ rad/sec}$       d)  $15 \text{ rad/sec}$
215. A circular disc of radius  $R$  is removed from a bigger circular disc of radius  $2R$ , such that the circumference of the discs coincide. The center of mass of the new disc is  $\frac{\alpha}{R}$  from the center of the bigger disc the value of  $\alpha$  is  
a)  $\frac{1}{3}$       b)  $\frac{1}{2}$       c)  $\frac{1}{6}$       d)  $\frac{1}{4}$
216. If solid sphere and solid cylinder of same radius and density rotate about their own axis, the moment of inertia will be greater for ( $L = R$ )  
a) Solid sphere      b) Solid cylinder      c) Both      d) Equal both
217. The moment of inertia of a thin rod of mass  $M$  and length  $L$ , about an axis perpendicular to the rod at a distance  $\frac{L}{4}$  from one end is  
a)  $\frac{ML^2}{6}$       b)  $\frac{ML^2}{12}$       c)  $\frac{7ML^2}{24}$       d)  $\frac{7ML^2}{48}$
218. The moments of inertia of two freely rotating bodies  $A$  and  $B$  are  $I_A$  and  $I_B$  respectively.  $I_A > I_B$  and their angular momenta are equal. If  $K_A$  and  $K_B$  are their kinetic energies, then  
a)  $K_A = K_B$       b)  $K_A > K_B$       c)  $K_A < K_B$       d)  $K_A = 2K_B$
219. The radius of gyration of a thin uniform circular disc (of radius  $R$ ) about an axis passing through its centre and lying in its plane is  
a)  $R$       b)  $\frac{R}{\sqrt{2}}$       c)  $\frac{R}{4}$       d)  $\frac{R}{2}$
220. The position of a particle is given by  $\mathbf{r} = \hat{i} + 2\hat{j} - \hat{k}$  and its linear momentum is given by  $\mathbf{p} = 3\hat{i} + 4\hat{j} - 2\hat{k}$  then its angular momentum, about the origin is perpendicular to  
a)  $yz$ -plane      b)  $z$ -axis      c)  $y$ -axis      d)  $x$ -axis
221. Moment of inertia of a uniform circular disc about a diameter is  $I$ . Its moment of inertia about an axis  $\perp$  to its plane and passing through a point on its will be  
a)  $5I$       b)  $3I$       c)  $6I$       d)  $4I$
222. The angular velocity of a wheel increases from  $100 \text{ rps}$  to  $300 \text{ rps}$  in  $10 \text{ s}$ . The number of revolutions made during that time is  
a)  $600$       b)  $1500$       c)  $1000$       d)  $2000$
223. If linear density of a rod of length  $3 \text{ m}$  varies as  $\lambda = 2 + x$ , then the position of the centre of gravity of the rod is  
a)  $\frac{7}{3} \text{ m}$       b)  $\frac{12}{7} \text{ m}$       c)  $\frac{10}{7} \text{ m}$       d)  $\frac{9}{7} \text{ m}$
224. A wheel of mass  $10 \text{ kg}$  has a moment of inertia of  $160 \text{ kg-m}^2$  about its own axis, the radius of gyration will be  
a)  $10 \text{ m}$       b)  $8 \text{ m}$       c)  $6 \text{ m}$       d)  $4 \text{ m}$



225. Five particles of mass  $2\text{ kg}$  are attached to the rim of a circular disc of radius  $0.1\text{ m}$  & negligible mass. Moment of inertia of the system about the axis passing through the centre of the disc & perpendicular to its plane is  
 a)  $1\text{ kg-m}^2$                       b)  $0.1\text{ kg-m}^2$                       c)  $2\text{ kg-m}^2$                       d)  $0.2\text{ kg-m}^2$
226. If the external torque acting on a system  $\vec{\tau} = 0$ , then  
 a)  $\omega = 0$                       b)  $\alpha = 0$                       c)  $J = 0$                       d)  $F = 0$
227. A dancer is standing on a stool rotating about the vertical axis passing through its centre. She pulls her arms towards the body reducing her moment of inertia by factor of  $n$ . The new angular speed of turn table is proportional to  
 a)  $n$                       b)  $n^{-1}$                       c)  $n^0$                       d)  $n^2$
228. Two spherical bodies of the same mass  $M$  are moving with velocities  $v_1$  and  $v_2$ . These collide perfectly inelastically  
 a)  $\frac{1}{2}M(v_1 - v_2)^2$                       b)  $\frac{1}{2}M(v_1^2 - v_2^2)^2$                       c)  $\frac{1}{4}M(v_1 - v_2)^2$                       d)  $2M(v_1^2 - v_2^2)$
229. A mass  $m$  is moving with a constant velocity along a line parallel to  $x$ -axis. Its angular momentum with respect to origin on a  $z$ -axis is  
 a) Zero                      b) Remains constant                      c) Goes on increasing                      d) Goes on decreasing
230. A swimmer while jumping into water from a height easily forms a loop in the air, if  
 a) He pulls his arms and legs in                      b) He spreads his arms and legs                      c) He keeps himself straight                      d) None of the above
231. A pulley fixed to the ceiling carries a string with blocks of masses  $m$  and  $3m$  attached to its ends. The masses of string and pulley are negligible. When the system is released, the acceleration of center of mass will be  
 a) Zero                      b)  $-\frac{g}{4}$                       c)  $\frac{g}{2}$                       d)  $-\frac{g}{2}$
232. One solid sphere  $A$  and another hollow sphere  $B$  are of same mass and same outer radius. Their moments of inertia about their diameters are respectively  $I_A$  and  $I_B$  such that  
 a)  $I_A = I_B$                       b)  $I_A > I_B$                       c)  $I_A < I_B$                       d)  $\frac{I_A}{I_B} = \frac{d_A}{d_B}$
233. A uniform rod of length  $2L$  is placed with one end in contact with the horizontal and is then inclined at an angle  $\alpha$  to the horizontal and allowed to fall without slipping at contact point. When it becomes horizontal, its angular velocity will be  
 a)  $\omega = \sqrt{\frac{3g \sin \alpha}{2L}}$                       b)  $\omega = \sqrt{\frac{2L}{3g \sin \alpha}}$                       c)  $\omega = \sqrt{\frac{6g \sin \alpha}{2L}}$                       d)  $\omega = \sqrt{\frac{2L}{g \sin \alpha}}$
234. A solid cylinder (SC) a hollow cylinder (HC) and a solid sphere (S) of the same mass and radius are released simultaneously from the same height of incline. The order in which these bodies reach the bottom of the incline is  
 a) SC, HC, S                      b) SC, S, HC                      c) S, SC, HC                      d) HC, SC, S
235. Masses  $8, 2, 4, 2\text{ kg}$  are placed at the corners  $A, B, C, D$  respectively of a square  $ABCD$  of diagonal  $80\text{ cm}$ . The distance of centre of mass from  $A$  will be  
 a)  $20\text{ cm}$                       b)  $30\text{ cm}$                       c)  $40\text{ cm}$                       d)  $60\text{ cm}$
236. The moment of inertia of a solid sphere about an axis passing through centre of gravity is  $\frac{2}{5}MR^2$ , then its radius of gyration about a parallel axis at a distance  $2R$  from first axis is  
 a)  $5R$                       b)  $\sqrt{\frac{22}{5}}R$                       c)  $\frac{5}{2}R$                       d)  $\sqrt{\frac{12}{5}}R$



237. A small disc of radius  $2\text{ cm}$  is cut from a disc of radius  $6\text{ cm}$ . If the distance between their centres is  $3.2\text{ cm}$ , what is the shift in the centre of mass of the disc  
 a)  $0.4\text{ cm}$                       b)  $2.4\text{ cm}$                       c)  $1.8\text{ cm}$                       d)  $1.2\text{ cm}$
238. A solid cylinder of mass  $M$  and radius  $R$  rolls without slipping down an inclined plane of length  $L$  and height  $h$ . What is the speed of its centre of mass when the cylinder reaches its bottom  
 a)  $\sqrt{\frac{3}{4}gh}$                       b)  $\sqrt{\frac{4}{3}gh}$                       c)  $\sqrt{4gh}$                       d)  $\sqrt{2gh}$
239. Which is a vector quantity  
 a) Work                      b) Power                      c) Torque                      d) Gravitational constant
240. What is the moment of inertia of solid sphere of density  $\rho$  and radius  $R$  about its diameter?  
 a)  $\frac{105}{176}R^5\rho$                       b)  $\frac{105}{176}R^2\rho$                       c)  $\frac{176}{105}R^5\rho$                       d)  $\frac{176}{105}R^2\rho$
241. A fly wheel of moment of inertia  $3 \times 10^2\text{ kg m}^2$  is rotating with uniform angular speed of  $4.6\text{ rad s}^{-1}$ . If a torque of  $6.9 \times 10^2\text{ N m}$  retards the wheel, then the time in which the wheel comes to rest is  
 a)  $1.5\text{ s}$                       b)  $2\text{ s}$                       c)  $0.5\text{ s}$                       d)  $1\text{ s}$
242. The moment of inertia of a circular disc of radius  $2\text{ m}$  and mass  $1\text{ kg}$  about an axis passing through the centre of mass but perpendicular to the plane of the disc is  $2\text{ kg m}^2$ . Its moment of inertia about an axis parallel to this axis but passing through the edge of the disc is ..... (see the given figure)

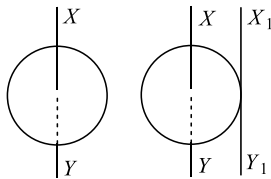

- a)  $8\text{ kgm}^2$                       b)  $4\text{ kgm}^2$                       c)  $10\text{ kgm}^2$                       d)  $6\text{ kgm}^2$
243. Four particles each of mass  $m$  are lying symmetrically on the rim of a disc of mass  $M$  and radius  $R$ . Moment of inertia of this system about an axis passing through one of the particles and perpendicular to plane of disc is  
 a)  $16mR^2$                       b)  $(3M + 16m)\frac{R^2}{2}$                       c)  $(3M + 12m)\frac{R^2}{2}$                       d) Zero
244. A solid sphere of mass  $500\text{ g}$  and radius  $10\text{ cm}$  rolls without slipping with the velocity  $20\text{ cm/s}$ . The total kinetic energy of the sphere will be  
 a)  $0.014\text{ J}$                       b)  $0.028\text{ J}$                       c)  $280\text{ J}$                       d)  $140\text{ J}$
245. A thin uniform square lamina of side  $a$  is placed in the  $xy$ -plane with its sides parallel to  $x$  and  $y$ -axis and with its centre coinciding with origin. Its moment of inertia about an axis passing through a point on the  $y$ -axis at a distance  $y = 2a$  and parallel to  $x$ -axis is equal to its moment of inertia about an axis passing through a point on the  $x$ -axis at a distance  $x = d$  and perpendicular to  $xy$ -plane. Then value of  $d$  is  
 a)  $\frac{7}{3}a$                       b)  $\sqrt{\frac{47}{12}}a$                       c)  $\frac{9}{5}a$                       d)  $\sqrt{\frac{51}{12}}a$
246. In the given figure, two bodies of mass  $m_1$  and  $m_2$  are connected by massless spring of force constant  $k$  and are placed on a smooth surface (shown in figure), then

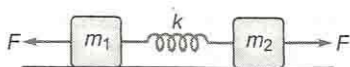

- a) The acceleration of b) The acceleration of c) The system always d) None of the above  
 centre of mass                      centre of mass                      remains in rest



- must be zero at every instant      may be zero at every instant
247. A horizontal platform is rotating with uniform angular velocity around the vertical axis passing through its centre. At some instant of time a viscous fluid of mass ' $m$ ' is dropped at the centre and is allowed to spread out and finally fall. The angular velocity during this period
- a) Decreases continuously      b) Decreases initially and increases again      c) Remains unaltered      d) Increases continuously
248. Out of the given bodies (of same mass) for which the moment of inertia will be maximum about the axis passing through its centre of gravity and perpendicular to its plane
- a) Disc of radius  $a$       b) Ring of radius  $a$       c) Square lamina of side  $2a$       d) Four rods of length  $2a$  making a square
249. The rectangular block shown in the figure is rotated in turn about  $x - x$ ,  $y - y$  and  $z - z$  axes passing through its centre of mass  $O$ . Its moment of inertia is
- 
- a) Same about all the three axes      b) Maximum about  $z - z$  axis      c) Equal about  $x - x$  and  $y - y$  axes      d) Maximum about  $y - y$  axis
250. A uniform rod of length  $L$  and mass  $1.8 \text{ kg}$  is made to rest on two measuring scale at its two ends. A uniform block of mass  $2.7 \text{ kg}$  is placed on the rod at a distance  $L/4$  from the left end. The force experienced by the measuring scale on the right end is
- a)  $18 \text{ N}$       b)  $27 \text{ N}$       c)  $29 \text{ N}$       d)  $45 \text{ N}$
251. The moment of inertia of a flywheel having kinetic energy  $360 \text{ J}$  and angular speed of  $20 \text{ rad/s}$  is
- a)  $18 \text{ kgm}^2$       b)  $1.8 \text{ kgm}^2$       c)  $2.5 \text{ kgm}^2$       d)  $9 \text{ kgm}^2$
252. The angular momentum of a wheel changes from  $2L$  to  $5L$  in  $3 \text{ seconds}$ . What is the magnitude of the torque acting on it
- a)  $L$       b)  $L/2$       c)  $L/3$       d)  $L/5$
253. When the angle of inclination of an inclined plane is  $\theta$ , an object slides down with uniform velocity. If the same object is pushed up with a initial velocity  $u$  on the same inclined plane; it goes up the plane and stops at a certain distance on the plane. Thereafter the body
- a) Slides down the inclined plane and reaches the ground with velocity  $u$ .      b) Slides down the inclined plane and reaches the ground with velocity less than  $u$ .      c) Slides down the inclined plane and reaches the ground with velocity greater than  $u$ .      d) Stays at rest on the inclined plane and will not slide down.
254. Moment of inertia of ring about its diameter is  $I$ . Then, moment of inertia about an axis passing through centre perpendicular to its plane is
- a)  $2I$       b)  $\frac{I}{2}$       c)  $\frac{3}{2}I$       d)  $I$
255. Three identical metal balls each of radius  $r$  are placed touching each other on a horizontal surface such that an equilateral triangle is formed, when centres of three balls are joined. The centre of the mass of system is located at
- a) Horizontal surface      b) Centre of one of the balls      c) Line joining centres of any two balls      d) Point of intersection of the medians



256. Two bodies have their moments of inertia  $I$  and  $2I$  respectively about their axis of rotation. If their kinetic energies of rotation are equal, their angular momentum will be in the ratio

- a)  $1 : 2$                       b)  $\sqrt{2} : 1$                       c)  $2 : 1$                       d)  $1 : \sqrt{2}$

257. A wheel rotates with a constant angular velocity of 300 rpm. The angle through which the wheel rotates in 1 s is

- a)  $\pi$  rad                      b)  $5\pi$  rad                      c)  $10\pi$  rad                      d)  $20\pi$  rad

258. Identify the increasing order of the angular velocities of the following :

1. Earth rotating about its own axis
2. Hour's hand of a clock
3. Second's hand of a clock
4. Flywheel of radius 2 m making 300 rpm

- a) 1, 2, 3, 4                      b) 2, 3, 4, 1                      c) 3, 4, 1, 2                      d) 4, 1, 2, 3

259. A ball strikes a horizontal floor at an angle  $\theta = 45^\circ$ . The coefficient of restitution between the ball and the floor is  $e = 1/2$ . The fraction of its kinetic energy lost in collision is

- a)  $5/8$                       b)  $3/8$                       c)  $3/4$                       d)  $1/4$

260. A force of 200 N acts tangentially on the rim of a wheel 25 cm in radius. Find the torque

- a) 50 Nm                      b) 150 Nm                      c) 75 Nm                      d) 39 Nm

261. Moment of inertia of a sphere of mass  $M$  and radius  $R$  is  $I$ . Keeping  $M$  constant if a graph is plotted between  $I$  and  $R$ , then its form would be

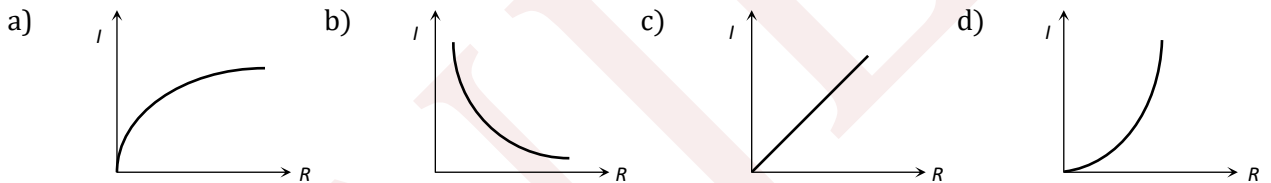

262. Four bodies of equal mass start moving with same speed are shown in the figure. In which of the following combination the centre of mass will remain at origin?

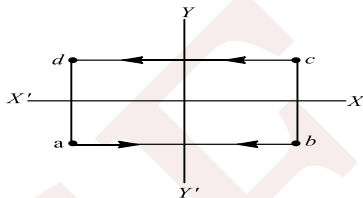

- a)  $cd$                       b)  $ab$                       c)  $ac$                       d)  $bd$

263. A solid sphere of radius  $R$  has moment of inertia  $I$  about its geometrical axis. If it is melted into a disc of radius  $r$  and thickness  $t$ . If its moment of inertia about the tangential axis (which is perpendicular to plane of the disc), is also equal to  $I$ , then the value of  $r$  is equal to

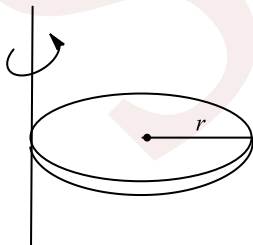

- a)  $\frac{2}{\sqrt{15}} R$                       b)  $\frac{2}{\sqrt{5}} R$                       c)  $\frac{3}{\sqrt{15}} R$                       d)  $\frac{\sqrt{3}}{\sqrt{15}} R$

264. One circular ring and one circular disc, both are having the same mass and radius. The ratio of their moments of inertia about the axes passing through their centres and perpendicular to their planes, will be

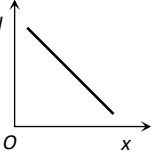
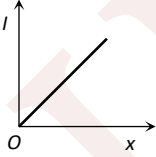
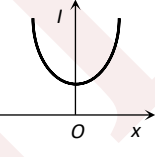
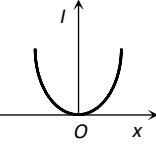
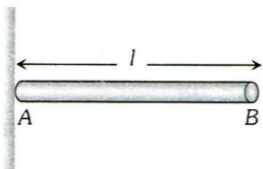

265. a) 1 : 1                      b) 2 : 1                      c) 1 : 2                      d) 4 : 1  
Moment of inertia of ring of mass  $M$  and radius  $R$  about an axis passing through the centre and perpendicular to the plane is  $I$ . What is the moment of inertia about its diameter?
- a)  $I$                       b)  $\frac{I}{2}$                       c)  $\frac{I}{\sqrt{2}}$                       d)  $I + MR^2$
266. A uniform cylinder has a radius  $R$  and length  $L$ . If the moment of inertia of this cylinder about an axis passing through its centre and normal to its circular face is equal to the moment of inertia of the same cylinder about an axis passing through its centre and perpendicular to its length, then
- a)  $L = R$                       b)  $L = \sqrt{3}R$                       c)  $L = \frac{R}{\sqrt{3}}$                       d)  $L = \sqrt{\frac{3}{2}}R$
267. A ball falls freely from a height of 45m. When the ball is at a height of 25 m, it explodes into two equal pieces. One of them moves horizontally with a speed of  $10 \text{ ms}^{-1}$ . The distance between the two pieces when both strike the ground is
- a) 10 m                      b) 20 m                      c) 15 m                      d) 30 m
268. A body comes running and sits on a rotating platform. What is conserved
- a) Linear momentum    b) Kinetic energy    c) Angular momentum    d) None of the above
269. According to the theorem of parallel axes  $I = I_{cm} + Mx^2$ , the graph between  $I$  and  $x$  will be
- a)     b)     c)     d) 
270. A uniform rod  $AB$  of length  $l$  and mass  $m$  is free to rotate about point  $A$ . The rod is released from rest in horizontal position. Given that the moment of inertia of the rod about  $A$  is  $\frac{ml^2}{3}$  the initial angular acceleration of the rod will be
- 
- a)  $\frac{2g}{3l}$                       b)  $mg \frac{l}{2}$                       c)  $\frac{3}{2}gl$                       d)  $\frac{3g}{2l}$
271. A small disc of radius 2 cm is cut from a disc of radius 6 cm. If the distance between their centres is 3.2 cm, what is the shift in the centre of mass of the disc?
- a) 0.4 cm                      b) 2.4 cm                      c) 1.8 cm                      d) 1.2 cm
272. Two spheres of masses  $2M$  and  $M$  are initially at rest at a distance  $R$  apart. Due to mutual force of attraction, they approach each other. When they are at separation  $R/2$ , the acceleration of the centre of mass of spheres would be
- a)  $0 \text{ m/s}^2$                       b)  $g \text{ m/s}^2$                       c)  $3g \text{ m/s}^2$                       d)  $12g \text{ m/s}^2$
273. A ring of radius  $0.5 \text{ m}$  and mass  $10 \text{ kg}$  is rotating about its diameter with angular velocity of  $20 \text{ rad/s}$ . Its kinetic energy is
- a) 10 J                      b) 100 J                      c) 500 J                      d) 250 J
274. A body of moment of inertia of  $3 \text{ kg-m}^2$  rotating with an angular velocity of  $2 \text{ rad/sec}$  has the same kinetic energy as a mass of  $12 \text{ kg}$  moving a velocity of
- a)  $8 \text{ m/s}$                       b)  $0.5 \text{ m/s}$                       c)  $2 \text{ m/s}$                       d)  $1 \text{ m/s}$
275. Before jumping in water from above a swimmer bends his body to



- a) Increase moment of inertia    b) Decrease moment of inertia    c) Decrease the angular momentum    d) Reduce the angular velocity

276. A cart of mass  $M$  is tied by one end of a massless rope of length  $10m$ . The other end of the rope is in the hands of a man of mass  $M$ . The entire system is on a smooth horizontal surface. The man is at  $x = 0$  and the cart at  $x = 10m$ . If the man pulls the cart by the rope, the man and the cart will meet at the point

- a)  $x = 0$     b)  $x = 5m$     c)  $x = 10m$     d) They will never meet

277. Four thin rods of same mass  $M$  and same length  $l$ , form a square as shown in figure. Moment of inertia of this system about an axis through centre  $O$  and perpendicular to its plane is

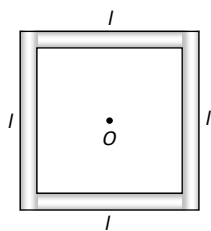

- a)  $\frac{4}{3} Ml^2$     b)  $\frac{Ml^2}{3}$     c)  $\frac{Ml^2}{6}$     d)  $\frac{2}{3} Ml^2$

278. Three identical spheres of mass  $M$  each are placed at the corners of an equilateral triangle of side  $2m$ . Taking one of the corners as the origin, the position vector of the centre of mass is

- a)  $\sqrt{3}(\hat{i} - \hat{j})$     b)  $\frac{\hat{i}}{\sqrt{3}} + \hat{j}$     c)  $\hat{i} + \hat{j}/3$     d)  $\hat{i} + \hat{j}/\sqrt{3}$

279. When a disc is rotating with angular velocity  $\omega$ , a particle situated at a distance of  $4\text{ cm}$  just begins to slip. If the angular velocity is doubled, at what distance will the particle start to slip?

- a)  $1\text{ cm}$     b)  $2\text{ cm}$     c)  $3\text{ cm}$     d)  $4\text{ cm}$

280. A solid sphere and a hollow sphere of the same material and of a same size can be distinguished without weighing

- a) By determining their moments of inertia about their coaxial axes    b) By rolling them simultaneously on an inclined plane    c) By rotating them about a common axis of rotation    d) By applying equal torque on them

281. As disc like reel with massless thread unrolls itself while falling vertically downwards the acceleration of its fall is

- a)  $g$     b)  $\frac{g}{2}$     c) Zero    d)  $\left(\frac{2}{3}\right)g$

282. Two stars of mass  $m_1$  and  $m_2$  are part of a binary star system. The radii of their orbits are  $r_1$  and  $r_2$  respectively, measured from the C.M. of the system. The magnitude of acceleration of  $m_1$  is

- a)  $\frac{m_1 m_2 G}{(r_1 + r_2)^2}$     b)  $\frac{m_1 G}{(r_1 + r_2)^2}$     c)  $\frac{m_2 G}{(r_1 + r_2)^2}$     d)  $\frac{(m_1 + m_2)}{(r_1 + r_2)^2}$

283. Two thin uniform circular rings each of radius  $10\text{ cm}$  and mass  $0.1\text{ kg}$  are arranged such that they have a common centre and their planes are perpendicular to each other. The moment of inertia of this system about an axis passing through their common centre and perpendicular to the plane of one of the rings in  $\text{kgm}^{-2}$  is

- a)  $15 \times 10^{-3}$     b)  $5 \times 10^{-3}$     c)  $1.5 \times 10^{-3}$     d)  $18 \times 10^{-4}$

284. A solid sphere, disc and solid cylinder all of the same mass are made of the same material are allowed to roll down (from rest) on an inclined plane, then



- a) Solid sphere reaches the bottom first      b) Solid sphere reaches the bottom last      c) Disc will reach the bottom first      d) All reach the bottom at the same time
285. Two discs of the same material and thickness have radii  $0.2\text{ m}$  and  $0.6\text{ m}$ . Their moments of inertia about their axes will be in the ratio  
a)  $1 : 81$       b)  $1 : 27$       c)  $1 : 9$       d)  $1 : 3$
286. The centre of mass of a system of two particles divides the distance them  
a) In inverse ratio of square of masses of particles      b) In direct ratio of square of masses of particles      c) In inverse ratio of masses of particles      d) In direct ratio of masses of particles
287. Angular momentum is conserved  
a) Always      b) Never      c) When external force is absent      d) When external torque is absent
288. A straight rod of length  $L$  has one of its ends at the origin and the other at  $x = L$ . If the mass per unit length of the rod is given by  $Ax$  is constant, where is its mass centre?  
a)  $L/3$       b)  $L/2$       c)  $2L/3$       d)  $3L/4$
289. A bag of mass  $M$  hangs by a long thread and a bullet (mass  $m$ ) comes horizontally with velocity  $v$  and gets caught in the bag. For the combined system of bag and bullet, the correct option is  
a) Momentum is  $\frac{mMv}{(m+M)}$       b) Kinetic energy is  $\frac{1}{2}Mv^2$       c) Momentum is  $mv$       d) Kinetic energy is  $\frac{1}{2} \frac{m^2v^2}{(M+m)}$
290. From a disc of radius  $R$ , a concentric circular portion of radius  $r$  is cut out so as to leave an annular disc of mass  $M$ . The moment of inertia of this annular disc about the axis perpendicular to its plane and passing through its centre of gravity is  
a)  $\frac{1}{2} M (R^2 + r^2)$       b)  $\frac{1}{2} M (R^2 - r^2)$       c)  $\frac{1}{2} M (R^4 + r^4)$       d)  $\frac{1}{2} M' (R^4 - r^4)$
291. The moment of inertia of a rod about an axis through its centre and perpendicular to it is  $\frac{1}{2}ML^2$  (where  $M$  is the mass and  $L$  is the length of the rod). The rod is bent in the middle so that the two halves makes an angular of  $60^\circ$ . The same axis would be  
a)  $\frac{1}{48}ML^2$       b)  $\frac{1}{12}ML^2$       c)  $\frac{1}{24}ML^2$       d)  $\frac{ML^2}{8\sqrt{3}}$
292. If the angular momentum of a rotating body about a fixed axis is increased by 10%. Its kinetic energy will be increased by  
a) 10%      b) 20%      c) 21%      d) 5%
293. From an inclined plane a sphere, a disc, a ring and a spherical shell are rolled without slipping. The order of their reaching at the base will be  
a) Ring, shell, disc, sphere      b) Shell, sphere, disc, ring      c) Sphere, disc, shell, ring      d) Ring, sphere, disc, shell
294. A cylinder rolls down an inclined plane of inclination  $30^\circ$ , the acceleration of cylinder is  
a)  $g/3$       b)  $g$       c)  $g/2$       d)  $2g/3$
295. A disc is rolling on the inclined plane, what is the ration of its rotational KE to the total KE?  
a) 1:3      b) 3:1      c) 1:2      d) 2:1
296. Angular momentum  $L$  of body with mass moment of inertia  $I$  and angular velocity  $\omega$  rad/sec is equal to  
a)  $\frac{I}{\omega}$       b)  $I\omega^2$       c)  $I\omega$       d) None of these
297. If a force acts on a body at a point away from the centre of mass, then

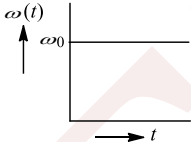
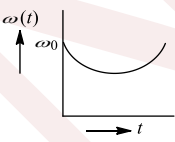
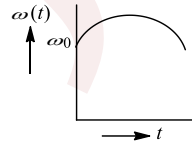
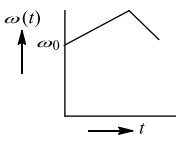

- a) Linear acceleration changes      b) Angular acceleration changes      c) Both change      d) None of these
298. The speed of a homogenous solid sphere after rolling down an inclined plane of vertical height  $h$  from rest without sliding is  
 a)  $\sqrt{\frac{10}{7}gh}$       b)  $\sqrt{\frac{4}{3}gh}$       c)  $\sqrt{gh}$       d)  $\sqrt{\frac{6gh}{5}}$
299. A solid cylinder is rolling down on an inclined plane of angle  $\theta$ . The coefficient of static friction between the plane and cylinder is  $\mu_s$ . Then condition for the cylinder not to slip is  
 a)  $\tan \theta \geq 3\mu_s$       b)  $\tan \theta > 3\mu_s$       c)  $\tan \theta \geq 3\mu_s$       d)  $\tan \theta < 3\mu_s$
300. Two blocks of masses  $m_1$  and  $m_2$  are connected by a massless spring and placed at smooth surface. The spring initially stretched and released. then  
 a) The momentum of each particle remains constant separately      b) The magnitude of momentum of both bodies are same to each other      c) The mechanical energy of system remains constant      d) Both (b) and (c) are correct.
301. A particle performs uniform circular motion with an angular momentum  $L$ . If the frequency of particle's motion is doubled and its KE is halved, the angular momentum becomes  
 a)  $\frac{L}{2}$       b)  $2L$       c)  $4L$       d)  $\frac{L}{4}$
302. A circular platform is free to rotate in a horizontal plane about a vertical axis passing through its centre. A tortoise is sitting at the edge of the platform. Now the platform is given an angular velocity  $\omega_0$ . When the tortoise moves along a chord of the platform with a constant velocity (w.r.t. the platform), the angular velocity of the platform will vary with the time  $t$  as  
 a)       b)       c)       d) 
303. Particles of masses  $m, 2m, 3m, \dots, nm$  grams are placed on the same line at distances  $l, 2l, 3l, \dots, nl$  cm from a fixed point. The distance of centre of mass of the particles from the fixed point in centimeters is  
 a)  $\frac{(2n+1)l}{3}$       b)  $\frac{l}{n+1}$       c)  $\frac{n(n^2+1)l}{2}$       d)  $\frac{2l}{n(n^2+1)}$
304. A small object of mass  $m$  is attached to a light string which passes through a hollow tube. The tube is hold by one hand and the string by the other. The object is set into rotation in a circle of radius  $R$  and velocity  $v$ . The string is then pulled down, shortening the radius of path of  $r$ . What is conserved  
 a) Angular momentum      b) Linear momentum      c) Kinetic energy      d) None of the above
305. Two rods each of mass  $m$  and length  $l$  are joined at the centre to form a cross. The moment of inertia of this cross about an axis passing through the common centre of the rods and perpendicular to the plane formed by them, is  
 a)  $ml^2/12$       b)  $ml^2/6$       c)  $ml^2/3$       d)  $ml^2/2$
306. The vector product of the force ( $F$ ) and distance ( $r$ ) from the centre of action represents  
 a) KE      b) PE      c) Work      d) Torque
307. A rod of length  $l$  is hinged at one end and kept horizontal. It is allowed to fall. The velocity of the other end of the rod is



308. a)  $\sqrt{3gl}$                       b)  $\sqrt{2gl}$                       c)  $2Ml^2$                       d) None of these  
A solid cylinder rolls down an inclined plane of height  $3\text{ m}$  and reaches the bottom of plane with angular velocity of  $2\sqrt{2}\text{ rad. s}^{-1}$ . The radius of cylinder must be [Take  $g = 10\text{ms}^{-2}$ ]
309. a)  $5\text{ cm}$                       b)  $0.5\text{ cm}$                       c)  $\sqrt{10}\text{ cm}$                       d)  $\sqrt{5}\text{ m}$   
When two bodies collide elastically, the force of interaction between them is
310. a) Conservative                      b) Non-conservative                      c) Either                      d) Zero  
conservative or  
non-conservative  
A disc of moment of inertia  $\frac{9.8}{\pi^2}\text{ kg m}^2$  is rotating of  $600\text{ rpm}$ . If the frequency of rotation changes from  $600\text{ rpm}$  to  $300\text{ rpm}$ , then what is the work done
311. a)  $1467\text{ J}$                       b)  $1452\text{ J}$                       c)  $1567\text{ J}$                       d)  $1632\text{ J}$   
The distance of the centre of mass of the T-shaped plate from  $O$  is

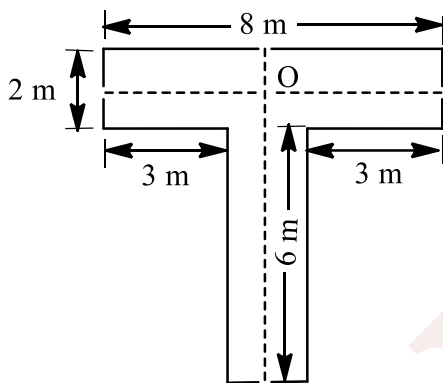

- a)  $7\text{ m}$                       b)  $2.7\text{ m}$                       c)  $4\text{ m}$                       d)  $1\text{ m}$
312. The moment of inertia of a circular ring of radius  $r$  and mass  $M$  about diameter is  
a)  $Mr^2$                       b)  $\frac{1}{2}Mr^2$                       c)  $\frac{3}{2}Mr^2$                       d)  $\frac{1}{4}Mr^2$
313. A solid sphere of mass  $1\text{ kg}$ , radius  $10\text{ cm}$  rolls down an inclined plane of height  $7\text{ m}$ . The velocity of its centre as it reaches the ground level is  
a)  $7\text{ m/s}$                       b)  $10\text{ m/s}$                       c)  $15\text{ m/s}$                       d)  $20\text{ m/s}$
314. Two discs have same mass and thickness. Their materials are of densities  $\rho_1$  and  $\rho_2$ . The ratio of their moment of inertia about central axis will be  
a)  $\rho_1:\rho_2$                       b)  $\rho_1\rho_2:1$                       c)  $1:\rho_1\rho_2$                       d)  $\rho_2:\rho_1$
315. A flywheel rotating about a fixed axis has a kinetic energy of  $360\text{ joule}$  when its angular speed is  $30\text{ rad/sec}$ . The moment of inertia of the wheel about the axis of rotation is  
a)  $0.6\text{ kg} \times \text{m}^2$                       b)  $0.15\text{ kg} \times \text{m}^2$                       c)  $0.8\text{ kg} \times \text{m}^2$                       d)  $0.75\text{ kg} \times \text{m}^2$
316. A particle of mass  $m$  moving with a velocity  $(3\hat{i} + 2\hat{j})\text{ms}^{-1}$  collides with a stationary body mass  $M$  and finally moves with a velocity  $(-2\hat{i} + \hat{j})\text{ms}^{-1}$ . If  $\frac{m}{M} = \frac{1}{13}$ , then  
The impulse                      The velocity of the                      The coefficient of                      All the above are  
a) received by each is b)  $M$  is  $\frac{1}{13}(5\hat{i} + \hat{j})$                       c) restitutions  $\frac{11}{7}$                       d) correct  
,  $m(5\hat{i} + \hat{j})$
317. The principle of conservation of angular momentum, states that angular momentum  
a) Always remains                      b) Is the product of                      c) Remains                      d) None of these  
conserved                      moment of inertia                      conserved until                      conserved until  
and velocity                      the torque acting                      on it remains                      constant



318. Two rings of the same radius and mass are placed such that their centres are at a common point and their planes are perpendicular to each other. The moment of inertia of the system about an axis passing through the centre and perpendicular to the plane of one of the rings is (mass of the ring =  $m$  and radius =  $r$ )

- a)  $\frac{1}{2}mr^2$                       b)  $mr^2$                       c)  $\frac{3}{2}mr^2$                       d)  $2mr^2$

319. When a torque acting upon a system is zero, then which of the following will be constant

- a) Force                      b) Linear momentum                      c) Angular momentum                      d) Linear impulse

320. The instantaneous velocity of a point  $B$  of the given rod of length  $0.5\text{ m}$  is  $3\text{ ms}^{-1}$  in the represented direction. The angular velocity of the rod for minimum velocity of end  $A$  is

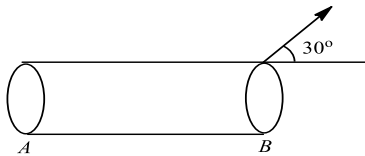

- a)  $1.5\text{ rads}^{-1}$                       b)  $5.2\text{ rads}^{-1}$                       c)  $2.5\text{ rads}^{-1}$                       d) None of these

321. A solid sphere rolls down two different inclined planes of same length, but of different inclinations. In both cases

- a) Speed and time of descent will be same                      b) Speed will be same, but time of descent will be different                      c) Speed will be different, but time of descent will be same                      d) Speed and time of descent both are different

322. The blocks  $A$  and  $B$ , each of mass  $m$ , are connected by massless spring of natural length  $L$  and spring constant  $k$ . The blocks are initially resting on a smooth horizontal floor with the spring at its natural length, as shown in figure. A third identical block  $C$ , also of mass  $m$ , moves on the floor with a speed  $v$  along the line joining  $A$  and  $B$ , and collides with  $A$ . Then



- a) The KE of the  $A - B$  system, at maximum compression of the spring, is zero                      b) The KE of the  $A - B$  system, at maximum compression of the spring is  $\frac{1}{4}mv^2$                       c) The maximum compression of the spring is  $v\sqrt{\frac{m}{k}}$                       d) The maximum compression of the spring is  $v\sqrt{\frac{m}{2k}}$

323. A reel of thread unrolls itself falling down under gravity. Neglecting mass of the thread, the acceleration of the reel is

- a)  $g$                       b)  $g/2$                       c)  $2g/3$                       d)  $4g/3$

324. A 'T' shaped object with dimensions shown in the figure, is lying on a smooth floor. A force ' $\vec{F}$ ' is applied at the point  $P$  parallel to  $AB$ , such that the object has only the translational motion without rotation. Find the location of  $P$  with respect to  $C$

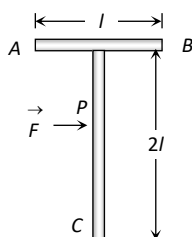

- a)  $\frac{4}{3}l$                       b)  $l$                       c)  $\frac{2}{3}l$                       d)  $\frac{3}{2}l$
325. If the external forces acting on a system have zero resultant, the center of mass  
a) May move but not accelerate    b) May Accelerate    c) Must not move    d) None of the above
326. A bomb at rest explodes in air into two equal fragments. If one of the fragments is moving vertically upwards with velocity  $v_0$ , then the other fragment will move  
a) Vertically up with velocity  $v_0$     b) Vertically down with velocity  $v_0$     c) In arbitrary direction with velocity  $v_0$     d) Horizontally with velocity  $v_0$
327. A body is rolling down an inclined plane. Its translational and rotational kinetic energies are equal. The body is a  
a) Solid sphere    b) Hollow sphere    c) Solid cylinder    d) Hollow cylinder
328. A drum of radius  $R$  and mass  $M$ , rolls down without slipping along an inclined plane of angle  $\theta$ . The frictional force  
a) Converts translational energy to rotational energy    b) Dissipates energy as heat    c) Decreases the rotational motion    d) Decreases the rotational and translational motions
329. A solid sphere of mass 2 kg rolls on a smooth horizontal surface at  $10 \text{ ms}^{-1}$ . It then rolls up a smooth inclined plane of inclination  $30^\circ$  with the horizontal. The height attained by the sphere before it stops is  
a) 700 cm    b) 701 cm    c) 7.1 m    d) None of these
330. Two bodies are projected from roof with same speed in different directions. If air resistance is not taken into account then  
a) They reach at ground with same magnitude of momenta if bodies have same masses    b) They reach at ground with same kinetic energy    c) They reach at ground with same speed    d) Both (a) and (c) are correct
331. A cylinder rolls down an inclined plane of inclination  $30^\circ$ , the acceleration of cylinder is  
a)  $\frac{g}{3}$     b)  $g$     c)  $\frac{g}{2}$     d)  $\frac{2g}{3}$
332. A ball moving with a certain velocity hits another identical ball at rest. If the plane is frictionless and collision is elastic, the angle between the directions in which the balls move after collision, will be  
a)  $30^\circ$     b)  $60^\circ$     c)  $90^\circ$     d)  $120^\circ$
333. A ring of radius  $R$  is first rotated with an angular velocity  $\omega_0$  and then carefully placed on a rough horizontal surface. The coefficient of friction between the surface and the ring is  $\mu$ . Time after which its angular speed is reduced to half is  
a)  $\frac{\omega_0 \mu R}{2g}$     b)  $\frac{2\omega_0 R}{\mu g}$     c)  $\frac{\omega_0 R}{2\mu g}$     d)  $\frac{\omega_0 g}{2\mu R}$
334. A small object of uniform density roll up a curved surface with an initial velocity  $v$ . If reaches up to a maximum height of  $\frac{3v^2}{4g}$  with respect to the initial position. The object is



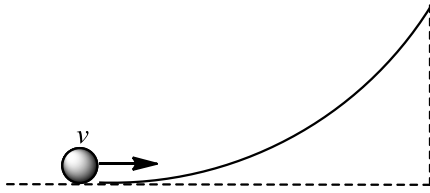

- a) Ring                      b) Solid sphere                      c) Hollow sphere                      d) Disc
335. A cylinder of 500 g and radius 10 cm has moment of inertia (about its natural axis)  
a)  $2.5 \times 10^{-3} \text{ kg-m}^2$     b)  $2 \times 10^{-3} \text{ kg-m}^2$     c)  $5 \times 10^{-3} \text{ kg-m}^2$     d)  $3.5 \times 10^{-3} \text{ kg-m}^2$
336. Two objects of masses 200g and 500g possess velocities  $10\hat{i} \text{ m/s}$  and  $3\hat{i} + 5\hat{j} \text{ m/s}$  respectively. The velocity of their centre of mass in m/s is  
a)  $5\hat{i} - 25\hat{j}$                       b)  $\frac{5}{7}\hat{i} - 25\hat{j}$                       c)  $5\hat{i} + \frac{25}{7}\hat{j}$                       d)  $25\hat{i} - \frac{5}{7}\hat{j}$
337. The moment of inertia of a sphere of mass  $M$  and radius  $R$  about an axis passing through its centre is  $\frac{2}{5}MR^2$ . The radius of gyration of the sphere about a parallel axis to the above and tangent to the sphere is  
a)  $\frac{7}{5}R$                       b)  $\frac{3}{5}R$                       c)  $\left(\sqrt{\frac{7}{5}}\right)R$                       d)  $\left(\sqrt{\frac{3}{5}}\right)R$
338. A thin uniform rod of length  $l$  and mass  $m$  is swinging freely about a horizontal axis passing through its end. Its maximum angular speed is  $\omega$ . Its centre of mass rises to maximum height of  
a)  $\frac{1}{3} \frac{l^2\omega^2}{g}$                       b)  $\frac{1}{6} \frac{l\omega}{g}$                       c)  $\frac{1}{2} \frac{l^2\omega^2}{g}$                       d)  $\frac{1}{6} \frac{l^2\omega^2}{g}$
339. A circular disc rolls down an inclined plane. The ration of rotational kinetic energy to total kinetic energy is  
a)  $\frac{1}{2}$                       b)  $\frac{1}{3}$                       c)  $\frac{2}{3}$                       d)  $\frac{3}{4}$
340. Two particles of masses  $m_1$  and  $m_2$  in projectile motion have velocities  $\vec{v}_1$  and  $\vec{v}_2$  respectively at time  $t = 0$ . They collide at time  $t_0$ . Their velocities become  $\vec{v}'_1$  and  $\vec{v}'_2$  at time  $2t_0$  while still moving in air. The value of  $[(m_1\vec{v}'_1 + m_2\vec{v}'_2) - (m_1\vec{v}_1 - m_2\vec{v}_2)]$  is  
a) Zero                      b)  $(m_1 + m_2)gt_0$                       c)  $2(m_1 + m_2)gt_0$                       d)  $\frac{1}{2}(m_1 + m_2)gt_0$
341. In case of explosion of a bomb, which of the following changes?  
a) Kinetic energy    b) Mechanical energy    c) Chemical energy    d) Energy
342. There are two identical balls of same material, one being solid and the other being hollow. How will you distinguish them without weighing?  
a) By spinning them using equal torques    b) By determining their moment of inertia    c) By rolling them down an inclined plane    d) By any one of these methods
343. Two blocks A and B are connected by a massless string (shown in figure). A force of 30 N is applied on block B. The distance travelled by centre of mass in 2 s starting from rest is

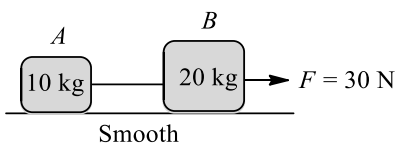

- a) 1 m                      b) 2 m                      c) 3 m                      d) None of these



344. Calculate the angular momentum of a body whose rotational energy is 10 Joule. If the angular momentum vector coincides with the axis of rotation and its moment of inertia about this axis is  $8 \times 10^{-7} \text{ kg m}^2$   
 a)  $4 \times 10^{-3} \text{ kg m}^2/\text{s}$  b)  $2 \times 10^{-3} \text{ kg m}^2/\text{s}$  c)  $6 \times 10^{-3} \text{ kg m}^2/\text{s}$  d) None of these
345. The acceleration of the centre of mass of a uniform solid disc rolling down an inclined plane of angle  $\alpha$  is  
 a)  $g \sin \alpha$  b)  $2/3 g \sin \alpha$  c)  $1/2 g \sin \alpha$  d)  $1/3 g \sin \alpha$
346. (1) Centre of gravity (C. G.) of a body is the point at which the weight of the body acts  
 (2) Centre of mass coincides with the centre of gravity if the earth is assumed to have infinitely large radius  
 (3) To evaluate the gravitational field intensity due to any body at an external point, the centre mass of the body can be considered to be concentrated at its C.G.  
 (4) The radius of gyration of any body rotating about an axis is the length of the perpendicular dropped from the C.G. of the body to the axis  
 Which one of the following pairs of statements is correct  
 a) (4) and (1) b) (1) and (2) c) (2) and (3) d) (3) and (4)
347. The ratio of the radii of gyration of a circular disc to that of a circular ring, each of same mass and radius, around their respective axes is  
 a)  $\sqrt{2} : 1$  b)  $\sqrt{2} : \sqrt{3}$  c)  $\sqrt{3} : \sqrt{2}$  d)  $1 : \sqrt{2}$
348. The centre of mass of a system of two particles divides. The distance between them is  
 a) In inverse ratio of square of masses of particles b) In direct ratio of square of masses of particles c) In inverse ratio of masses of particles d) In direct ratio of masses of particles
349. If the earth is a point mass of  $6 \times 10^{24} \text{ kg}$  revolving around the sun at a distance of  $1.5 \times 10^8 \text{ km}$  and in time  $T = 3.14 \times 10^7 \text{ s}$ , then the angular momentum of the earth around the sun is  
 a)  $1.2 \times 10^{18} \text{ kg m}^2/\text{s}$  b)  $1.8 \times 10^{29} \text{ kg m}^2/\text{s}$  c)  $1.5 \times 10^{37} \text{ kg m}^2/\text{s}$  d)  $2.7 \times 10^{40} \text{ kg m}^2/\text{s}$
350. Three stationary particles A, B, C of masses  $m_A, m_B$  and  $m_C$  are under the action of same constant force for the same time. If  $m_A > m_B > m_C$ , the variation of momentum of particles with time for each will be correctly shown as

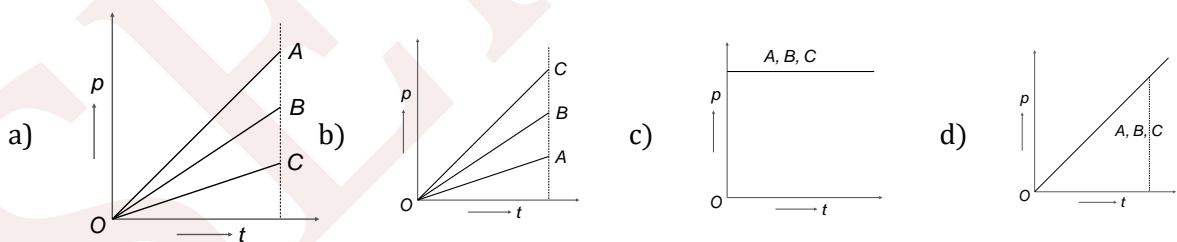

351. Three point masses each of mass  $m$  are placed at the corners of an equilateral triangle of side ' $a$ '. Then the moment of inertia of this system about an axis passing along one side of the triangle is  
 a)  $ma^2$  b)  $3ma^2$  c)  $3/4 ma^2$  d)  $2/3 ma^2$
352. From a circular ring of mass  $M$  and  $R$ , an arc corresponding to a  $90^\circ$  sector is removed. The moment of inertia of the remaining part of the ring about an axis passing through the ring and perpendicular to the plane of ring is  $k$  times  $MR^2$ . Then the value of  $k$  is  
 a)  $\frac{3}{4}$  b)  $\frac{7}{8}$  c)  $\frac{1}{4}$  d) 1
353. Radius of gyration of uniform thin rod of length  $L$  about an axis passing normally through its centre of mass is  
 a)  $\frac{L}{\sqrt{12}}$  b)  $\frac{L}{12}$  c)  $\sqrt{12} L$  d)  $12 L$



354. The moment of inertia of a dumb-bell, consisting of point masses  $m_1 = 2.0$  kg and  $m_2 = 1.0$  kg, fixed to the ends of a rigid massless rod of length  $L = 0.6$  m, about an axis passing through the centre of mass and perpendicular to its length, is  
 a)  $0.72 \text{ kg m}^2$       b)  $0.36 \text{ kg m}^2$       c)  $0.27 \text{ kg m}^2$       d)  $0.24 \text{ kg m}^2$
355. Two solid spheres ( $A$  and  $B$ ) are made of metals of different densities  $\rho_A$  and  $\rho_B$  respectively. If their masses are equal, the ratio of their moments of inertia ( $I_B/I_A$ ) about their respective diameters is  
 a)  $\left(\frac{\rho_B}{\rho_A}\right)^{2/3}$       b)  $\left(\frac{\rho_A}{\rho_B}\right)^{2/3}$       c)  $\frac{\rho_A}{\rho_B}$       d)  $\frac{\rho_B}{\rho_A}$
356. A solid sphere is given a kinetic energy  $E$ . What fraction of kinetic energy is associated with rotation?  
 a)  $3/7$       b)  $5/7$       c)  $1/2$       d)  $2/7$
357. The moment of inertia of a rectangular lamina about an axis perpendicular to the plane and passing through its centre of mass is  
 a)  $\frac{M}{12}(l^2 + b^2)$       b)  $\frac{M}{3}(l^2 + b^2)$       c)  $\frac{2Ml}{12}$       d)  $\frac{M(l + b)}{12}$
358. Moment of inertia of big drop in  $I$ . If 8 droplets are formed from big drop, then moment of inertia of small droplet is  
 a)  $\frac{I}{32}$       b)  $\frac{I}{16}$       c)  $\frac{I}{8}$       d)  $\frac{I}{4}$
359. A binary star consists of two stars  $A$  (mass  $2.2 M_s$ ) and  $B$  (mass  $11 M_s$ ), where  $M_s$  is the mass of the sun. They are separated by distance  $d$  and are rotating about their centre of mass, which is stationary. The ratio of the total angular momentum of the binary star to the angular momentum of star  $B$  about the centre of mass is  
 a) 7      b) 6      c) 9      d) 10
360. Three rods each of length  $L$  and mass  $M$  are placed along  $X, Y$  and  $Z$  axes in such a way that one end of each rod is at the origin. The moment of inertia of the system about  $Z$ -axis is  
 a)  $\frac{ML^2}{3}$       b)  $\frac{2ML^2}{3}$       c)  $\frac{3ML^2}{2}$       d)  $\frac{2ML^2}{12}$
361. The total kinetic energy of a body of mass  $10 \text{ kg}$  and radius  $0.5 \text{ m}$  moving with a velocity of  $2 \text{ m/s}$  without slipping is  $32.8 \text{ joule}$ . The radius of gyration of the body is  
 a)  $0.25 \text{ m}$       b)  $0.2 \text{ m}$       c)  $0.5 \text{ m}$       d)  $0.4 \text{ m}$
362. A body having moment of inertia about its axis of rotation equal to  $3 \text{ kg} - \text{m}^2$  is rotating with angular velocity equal to  $3 \text{ rad/s}$ . Kinetic energy of this rotating body is the same as that of body of mass  $27 \text{ kg}$  moving with a speed of  
 a)  $1.0 \text{ m/s}$       b)  $0.5 \text{ m/s}$       c)  $1.5 \text{ m/s}$       d)  $2.0 \text{ m/s}$
363. A bullet of mass  $5 \text{ g}$  moving with a velocity  $10 \text{ ms}^{-1}$  strikes a stationary body of mass  $955 \text{ g}$  and enters it. The percentage loss of kinetic energy of the bullet is  
 a) 85      b) 0.05      c) 99.5      d) None of the above
364. A diatomic molecule is formed by two atoms which may be treated as mass points  $m_1$  and  $m_2$ , joined by a massless rod of length  $r$ . Then the moment of inertia of the molecule about an axis passing through the centre of mass and perpendicular to rod is  
 a) zero      b)  $(m_1 + m_2)r^2$       c)  $\left(\frac{m_1+m_2}{m_1m_2}\right)r^2$       d)  $\left(\frac{m_1m_2}{m_1+m_2}\right)r^2$
365. A disc starting from rest acquires in 10 sec an angular velocity of 240 revolutions/minute. Its angular acceleration (assuming constant) is  
 a)  $1.52 \text{ rad/s}$       b)  $2.51 \text{ rad/s}$       c)  $3.11 \text{ rad/s}$       d)  $3.76 \text{ rad/s}$
366. A flywheel gains a speed of  $540 \text{ r.p.m.}$  in  $6 \text{ sec}$ . Its angular acceleration will be  
 a)  $3\pi \text{ rad/sec}^2$       b)  $9\pi \text{ rad/sec}^2$       c)  $18\pi \text{ rad/sec}^2$       d)  $54\pi \text{ rad/sec}^2$



367. Two spheres each of mass  $M$  and radius  $R/2$  are connected with a massless rod of length  $2R$  as shown in the figure. What will  $b$  be the moment of inertia of the system about an axis passing through the centre of one of the sphere and perpendicular to the rod

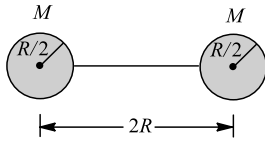

- a)  $\frac{21}{5}MR^2$       b)  $\frac{2}{5}MR^2$       c)  $\frac{5}{2}MR^2$       d)  $\frac{5}{21}MR^2$
368. Two rings have their moments of inertia in the ratio 2:1 and their diameters are in the ratio 2:1. The ratio of their masses will be  
a) 2 : 1      b) 1 : 2      c) 1 : 4      d) 1 : 1
369. The moment of inertia of a straight thin rod of mass  $M$  and length  $l$  about an axis perpendicular to its length and passing through its one end, is  
a)  $Ml^2/12$       b)  $Ml^2/3$       c)  $Ml^2/2$       d)  $Ml^2$
370. The position of a particle is given by:  $\vec{r} = (\hat{i} + 2\hat{j} - \hat{k})$  and momentum  $\vec{P} = (3\hat{i} + 4\hat{j} - 2\hat{k})$ . The angular momentum is perpendicular to  
a) X- axis      b) Y- axis      c) Z- axis      d) Line at equal angles to all the three axes
371. A sphere of mass  $m$  and radius  $r$  rolls on a horizontal plane without slipping with the speed  $u$ . Now if it rolls up vertically, the maximum height it would attain will be  
a)  $3u^2/4g$       b)  $5u^2/2g$       c)  $7u^2/10g$       d)  $u^2/2g$
372. A 10 kg body hangs at rest from a rope wrapped around a cylinder 0.2 m in diameter. The torque applied about the horizontal axis of the cylinder is  
a) 98 N-m      b) 19.6 N-m      c) 196 N-m      d) 9.8 N-m
373. The moment of inertia of a circular disc about one of its diameter is  $I$ . What will be its moment of inertia about a tangent parallel to the diameter?  
a)  $4I$       b)  $2I$       c)  $\frac{3}{2}I$       d)  $3I$
374. A thin metal disc of radius of 0.25 m and mass 2 kg starts from rest and rolls down on an inclined plane. If its rotational kinetic energy is 4 J at the foot of inclined plane, then the linear velocity at the same point, is in  $\text{ms}^{-1}$ .  
a) 2      b)  $2\sqrt{2}$       c)  $2\sqrt{3}$       d)  $3\sqrt{2}$
375. A ball rests upon a flat piece of paper on a table top. The paper is pulled horizontally but quickly towards right as shown. Relative to its initial position with respect to the table, the ball

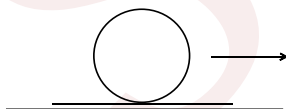

- (1) Remains stationary if there is no friction between the paper and the ball  
(2) Moves to the left and starts rolling backwards, *i. e.*, to the left if there is a friction between the paper and the ball  
(3) Moves forward, *i. e.*, in the direction in which the paper is pulled.

Here, the correct statement/s is/are

- a) Both (1) and (2)      b) Only (3)      c) Only (1)      d) Only (2)
376. A rectangular block has a square base measuring  $a \times a$ , and its height is  $h$ . Its moves on a horizontal surface in a direction perpendicular to one of its edges. The coefficient of friction is  $\mu$ . It will topple if



- a)  $\mu > h/a$       b)  $\mu > a/h$       c)  $\mu > \frac{2a}{h}$       d)  $\mu > \frac{a}{2h}$

377. Centre of mass is a point

- a) Which is geometric centre of a body      b) From which distance of particles are same      c) Where the whole mass of the body is supposed to be concentrated      d) Which is the origin of reference frame

378. When a ceiling fan is switched on, it makes 10 revolutions in the first 3 seconds. Assuming a uniform angular acceleration, how many rotation it will make in the next 3 seconds

- a) 10      b) 20      c) 30      d) 40

379. A thin rod of length  $L$  is lying along the  $x$ -axis with its ends at  $x = 0$  and  $x = L$ . Its linear density (mass/length) varies with  $x$  as  $k\left(\frac{x}{L}\right)^n$ , when  $n$  can be zero or any positive number. If the position  $x_{CM}$  of the centre of mass of the rod is plotted against  $n$ , which of the following graphs best approximates the dependence of  $x_{CM}$  on  $n$ ?

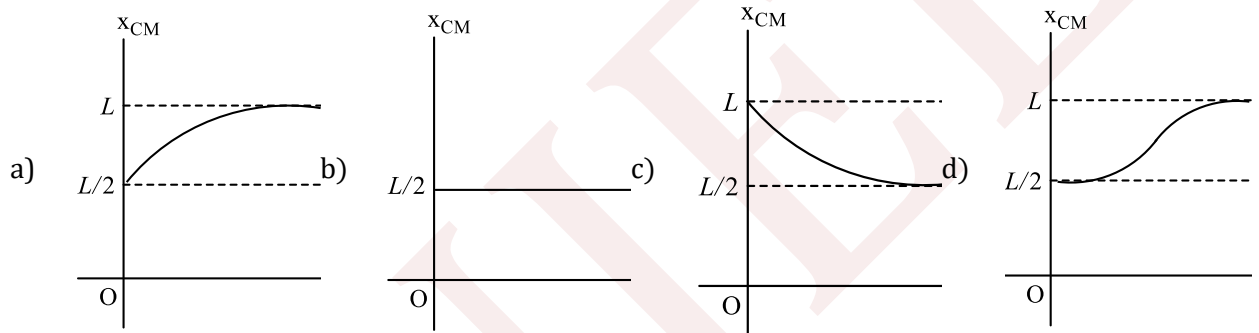

380. A 2 kg body and a 3 kg body are moving along the  $x$ -axis. At a particular instant the 2 kg body has a velocity of  $3 \text{ ms}^{-1}$  and the 3 kg body has the velocity of  $2 \text{ ms}^{-1}$ . The velocity of the centre of mass at that instant is

- a)  $5 \text{ ms}^{-1}$       b)  $1 \text{ ms}^{-1}$       c) 0      d) None of these

381. Consider a uniform square plate of side 'a' and mass 'm'. The moment of inertia of this plate about an axis perpendicular to its plane and passing through one of its corners is

- a)  $\frac{1}{12} ma^2$       b)  $\frac{7}{12} ma^2$       c)  $\frac{2}{3} ma^2$       d)  $\frac{5}{6} ma^2$

382. A circular disc of radius  $R$  and thickness  $\frac{R}{6}$  has moment of inertia  $I$  about an axis passing through its centre and perpendicular to its plane. It is melted and recasted into a solid sphere. The moment of inertia of the sphere about its diameter as axis of rotation is

- a)  $I$       b)  $\frac{2I}{3}$       c)  $\frac{I}{5}$       d)  $\frac{I}{10}$

383. A solid cylinder on moving with constant speed  $v_0$  reaches the bottom of an incline of  $30^\circ$ . A hollow cylinder of same mass and radius moving with the same constant speed  $v_0$  reaches the bottom of a different incline of  $\theta$ . There is no slipping and both of them go through the same distance in the same time ;  $\theta$  is then equal to

- a)  $37^\circ$       b)  $30^\circ$       c)  $42^\circ$       d)  $45^\circ$

384. The centre of mass of triangle shown in figure has coordinates

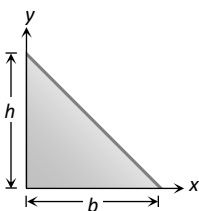

a)  $x = \frac{h}{2}, y = \frac{b}{2}$       b)  $x = \frac{b}{2}, y = \frac{h}{2}$       c)  $x = \frac{b}{3}, y = \frac{h}{3}$       d)  $x = \frac{h}{3}, y = \frac{b}{3}$

385. A body of mass  $M$  moving with a speed  $u$  has a head-on collision with a body of mass  $m$  originally at rest. If  $M \gg m$ , the speed of the body of mass  $m$  after collision will be nearly

a)  $\frac{um}{M}$       b)  $\frac{uM}{m}$       c)  $\frac{u}{2}$       d)  $2u$

386. A smooth steel ball strikes a fixed smooth steel plate at an angle  $\theta$  with the vertical. If the coefficient of restitution is  $e$ , the angle at which the rebound will take place is

a)  $\theta$       b)  $\tan^{-1} \left[ \frac{\tan \theta}{e} \right]$       c)  $e \tan \theta$       d)  $\tan^{-1} \left[ \frac{e}{\tan \theta} \right]$

387. If the earth shrinks such that its mass does not change but radius decreases to one quarter of its original value then one complete day will take

a) 96 h      b) 48 h      c) 6 h      d) 1.5 h

388. A circular turn table has a block of ice placed at its centre. The system rotates with an angular speed  $\omega$  about an axis passing through the centre of the table. If the ice melts on its own without any evaporation, the speed of rotation of the system

a) Becomes zero      b) Remains constant at the same value  $\omega$       c) Increases to a value greater than  $\omega$       d) Decreases to a value less than  $\omega$

389. Two blocks of masses 10 kg and 4 kg connected by a spring of negligible mass and placed on a frictionless horizontal surface. An impulse gives a velocity of  $14 \text{ ms}^{-1}$  to the heavier block in the direction of the lighter block. The velocity of the centre of mass is

a)  $30 \text{ ms}^{-1}$       b)  $20 \text{ ms}^{-1}$       c)  $10 \text{ ms}^{-1}$       d)  $5 \text{ ms}^{-1}$

390. A spherical hollow is made in a lead sphere of radius  $R$  such that its surface touches the outside surface of lead sphere and passes through the centre. What is the shift in the centre of lead sphere as a result of this hollowing?

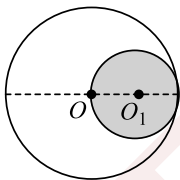

a)  $\frac{R}{7}$       b)  $\frac{R}{14}$       c)  $\frac{R}{2}$       d)  $R$

391. If the earth is treated as a sphere of radius  $R$  and mass  $M$ ; its angular momentum about axis of rotation with period  $T$  is

a)  $\frac{\pi MR^3}{T}$       b)  $\frac{MR^2\pi}{T}$       c)  $\frac{2\pi MR^3}{5T}$       d)  $\frac{4\pi MR^2}{5T}$

392. Two masses  $m_1$  and  $m_2$  ( $m_1 > m_2$ ) are connected by massless flexible and inextensible string passed over massless and frictionless pulley. The acceleration of centre of mass is

a)  $\left( \frac{m_1 - m_2}{m_1 + m_2} \right)^2 g$       b)  $\frac{m_1 - m_2}{m_1 + m_2} g$       c)  $\frac{m_1 + m_2}{m_1 - m_2} g$       d) Zero

393. A man of mass  $M$  stands at one end of a plank of length which is at rest on a frictionless horizontal surface. The man walks to the other end of the plank. If mass of the plank is  $M/3$ , the distance that the man moves relative to ground is

a)  $L$       b)  $L/4$       c)  $3L/4$       d)  $L/3$

394. Two discs of same thickness but of different radii are made of two different materials such that their masses are same. The densities of the materials are in the ratio 1:3. The moments of inertia of these discs about the respective axes passing through their centres and perpendicular to their planes will be in the ratio



395. A bullet of mass  $M$  hits a block of mass  $M'$ . The transfer to energy is maximum, when  
 a)  $1 : 3$                       b)  $3 : 1$                       c)  $1 : 9$                       d)  $9 : 1$   
 a)  $M' = M$                       b)  $M' = 2M$                       c)  $M' < M$                       d)  $M' > M$
396. Which relation is not correct of the following  
 a) Torque = Moment of inertia  $\times$  angular acceleration  
 b) Torque = Dipole moment  $\times$  magnetic induction  
 c) Moment of inertia = Torque/angular acceleration  
 d) Liner momentum = Moment of inertia  $\times$  angular velocity
397. If a ball is dropped from rest, its bounces from the floor. The coefficient of restitution is 0.5 and the speed just before the first bounce is  $5\text{ms}^{-1}$ . The total time taken by the ball to come to rest is  
 a) 2 s                      b) 1 s                      c) 0.5 s                      d) 0.25 s
398. Angular momentum of a system of particles changes when  
 a) Force acts on a body                      b) Torque acts on a body                      c) Direction of velocity changes                      d) None of these
399. The moment of inertia of meter scale of mass 0.6 kg about an axis perpendicular to the scale and located at the 20 cm position on the scale in  $\text{kg} \cdot \text{m}^2$  is (Breadth of the scale is negligible)  
 a) 0.078                      b) 0.104                      c) 0.148                      d) 0.208
400. A particle moves in the  $x$ - $y$  plane under the action of a force  $F$  such that the value of its linear momentum  $\vec{P}$  at any time  $t$  is  $p_x = 2 \cos t, p_y = 2 \sin t$   
 The angle  $\theta$  between  $\vec{F}$  and  $\vec{P}$  at a given time  $t$  will be  
 a)  $90^\circ$                       b)  $0^\circ$                       c)  $180^\circ$                       d)  $30^\circ$
401. The moment of inertia of a circular ring of mass 1 kg about an axis passing through centre and perpendicular to its plane is  $4\text{kg}\cdot\text{m}^2$ . The diameter of the ring is  
 a) 2 m                      b) 4 m                      c) 5 m                      d) 6 m
402. A particle of mass 1 kg is projected with an initial velocity  $10\text{ms}^{-1}$  at an angle of projection  $45^\circ$  with the horizontal. The average torque acting on the projectile, between the time at which it is projected and the time at which it strikes the ground, about the point of projection in newton-metre is  
 a) 25                      b) 50                      c) 75                      d) 100
403. Four spheres of diameter  $2a$  and mass  $M$  are placed with their centres on the four corners of a square of side  $b$ . Then the moment of inertia of the system about an axis along one of the sides of the square is  
 a)  $\frac{4}{5}M a^2 + 2M b^2$                       b)  $\frac{8}{5}M a^2 + 2M b^2$                       c)  $\frac{8}{5}M a^2$                       d)  $\frac{4}{5}M a^2 + M b^2$
404. A wheel has angular acceleration of  $3.0\text{rad}/\text{sec}^2$  and an initial angular speed of  $2.00\text{rad}/\text{sec}$ . In a time of 2 sec it has rotated through an angle (In radian) of  
 a) 6                      b) 10                      c) 12                      d) 4
405. When a sphere of moment of inertia  $I$  about its centre of gravity and mass ' $m$ ' rolls from rest down an inclined plane without slipping, its kinetic energy is  
 a)  $\frac{1}{2}I\omega^2$                       b)  $\frac{1}{2}mv^2$                       c)  $I\omega + mv$                       d)  $\frac{1}{2}I\omega^2 + \frac{1}{2}mv^2$
406. A thin uniform circular ring is rolling down an inclined plane of inclination  $30^\circ$  without slipping. Its linear acceleration along the inclined plane will be  
 a)  $g/2$                       b)  $g/3$                       c)  $g/4$                       d)  $2g/3$
407. A circular disc of radius  $R$  rolls without slipping along the horizontal surface with constant velocity  $v_0$ . We consider a point  $A$  on the surface of the disc. Then the acceleration of the point  $A$  is



- a) Constant in magnitude as well as direction      b) Constant in direction      c) Constant in magnitude      d) Constant
408. A torque of  $50 \text{ Nm}$  acting on a wheel at rest rotates it through  $200 \text{ radians}$  in  $5 \text{ sec}$ . Calculate the angular acceleration produced  
 a)  $8 \text{ rad sec}^{-2}$       b)  $4 \text{ rad sec}^{-2}$       c)  $16 \text{ rad sec}^{-2}$       d)  $12 \text{ rad sec}^{-2}$
409. A round uniform body of radius  $R$ , mass  $M$  and moment of inertia  $I$ , rolls down (without slipping) an inclined plane making an angle  $\theta$  with the horizontal. Then its acceleration is  
 a)  $\frac{g \sin \theta}{1 + \frac{I}{MR^2}}$       b)  $\frac{g \sin \theta}{1 + \frac{MR^2}{I}}$       c)  $\frac{g \sin \theta}{1 - \frac{I}{MR^2}}$       d)  $\frac{g \sin \theta}{1 - \frac{MR^2}{I}}$
410. A tap can be operated easily using two fingers because  
 a) The force available for the operation will be more      b) This helps application of angular forces      c) The rotational effect is caused by the couple formed      d) The force by one finger overcomes friction and other finger provides the force for the operation
411. The angular momentum of a system of particles is not conserved  
 a) When a net external force acts upon the system      b) When a net external torque is acting upon the system      c) When a net external impulse is acting upon the system      d) None of these
412. Two discs of moment of inertia  $I_1$  and  $I_2$  and angular speeds  $\omega_1$  and  $\omega_2$  are rotating along collinear axes passing through their centre of mass and perpendicular to their plane. If the two are made to rotate combindly along the same axis the rotational  $KE$  of system will be  
 a)  $\frac{I_1\omega_1 + I_2\omega_2}{2(I_1 + I_2)}$       b)  $\frac{(I_1 + I_2)(\omega_1 + \omega_2)^2}{2}$       c)  $\frac{(I_1\omega_1 + I_2\omega_2)^2}{2(I_1 + I_2)}$       d) None of these
413. A uniform rod of length ' $2L$ ' has mass per unit length ' $m$ '. The moment of inertia of the rod about an axis passing through its centre and perpendicular to its length is  
 a)  $\frac{2}{3}mL^2$       b)  $\frac{1}{3}mL^2$       c)  $\frac{2}{3}mL^3$       d)  $\frac{4}{3}mL^3$
414. A wheel of radius  $0.4 \text{ m}$  can rotate freely about its axis as shown in the figure. A string is wrapped over its rim and a mass of  $4 \text{ kg}$  is hung. An angular acceleration of  $8 \text{ rad-s}^{-2}$  is produced in it due to the torque. Then, moment of inertia of the wheel is ( $g = 10 \text{ ms}^{-2}$ )

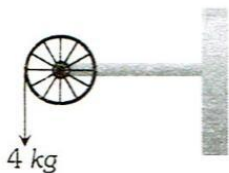

- a)  $2 \text{ kg} - \text{m}^2$       b)  $1 \text{ kg} - \text{m}^2$       c)  $4 \text{ kg} - \text{m}^2$       d)  $8 \text{ kg} - \text{m}^2$
415. Three particles, each of mass  $m$  gram, are situated at the vertices of an equilateral triangle  $ABC$  of side  $l \text{ cm}$  (as shown in the figure). The moment of inertia of the system about a line  $AX$  perpendicular to  $AB$  and in the plane of  $ABC$ , in  $\text{gram-cm}^2$  units will be



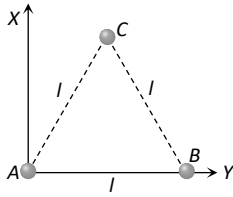

416. Four particles each of mass  $m$  are placed at the corners of a square of side length  $l$ . The radius of gyration of the system about an axis perpendicular to the square and passing through its centre is
- a)  $\frac{3}{4}ml^2$       b)  $2ml^2$       c)  $\frac{5}{4}ml^2$       d)  $\frac{3}{2}ml^2$
417. A ladder is leaned against a smooth wall and it is allowed to slip on a frictionless floor. Which figure represents trace of its centre of mass
- a)      b)      c)      d) 
  
←Time      ←Time      ←Time      ←Time
418. A ball rolls without slipping. The radius of gyration of the ball about an axis passing through its centre of mass is  $K$ . If radius of the ball be  $R$ , then the fraction of total energy associated with its rotational energy will be
- a)  $\frac{K^2}{R^2}$       b)  $\frac{K^2}{K^2 + R^2}$       c)  $\frac{R^2}{K^2 + R^2}$       d)  $\frac{K^2 + R^2}{R^2}$
419. A cylinder rolls up an inclined plane, reaches some height, and then rolls down (without slipping throughout these motions). The directions of the frictional force acting on the cylinder are
- a) Up the incline while ascending and down the incline while descending      b) Up the incline while ascending as well as descending      c) Down the incline while ascending and up the incline while descending      d) Down the incline while ascending as well as descending
420. If the angular momentum of any rotating body increases by 200%, then the increase in its kinetic energy
- a) 400%      b) 800%      c) 200%      d) 100%
421. Three point masses  $m_1, m_2, m_3$  are located at the vertices of an equilateral triangle of length ' $a$ '. The moment of inertia of the system about an axis along the altitude of the triangle passing through  $m_1$  is
- a)  $(m_2 + m_3)\frac{a^2}{4}$       b)  $(m_1 + m_2 + m_3)a^2$       c)  $(m_1 + m_2)\frac{a^2}{4}$       d)  $(m_2 + m_3)a^2$
422. Two point objects of mass 1.5 g and 2.5 g respectively are at a distance of 16 cm apart, the centre of gravity is at a distance  $x$  from the object of mass 1.5g, where  $x$  is
- a) 10 cm      b) 6 cm      c) 13 cm      d) 3 cm
423. A thin uniform rod mass  $m$  and length  $l$  is hinged at the lower end to a level floor and stands vertically. It is now allowed to fall, then its upper end will strike the floor with a velocity given by
- a)  $\sqrt{2gl}$       b)  $\sqrt{3gl}$       c)  $\sqrt{5gl}$       d)  $\sqrt{mgl}$
424. A solid sphere is rotating in free space. If the radius of the sphere is increased keeping mass same which one of the following will not be affected?



- a) Moment of inertia    b) Angular momentum    c) Angular velocity    d) Rotational kinetic energy

425. A circular disc rolls down an inclined plane. The ratio of rotational kinetic energy to total kinetic energy is

- a)  $\frac{1}{2}$     b)  $\frac{1}{3}$     c)  $\frac{2}{3}$     d)  $\frac{3}{4}$

426. A car is moving at a speed of  $72 \text{ km/hr}$ . The radius of its wheels is  $0.25 \text{ m}$ . If the wheels are stopped in 20 rotations by applying brakes, then angular retardation produced by the brakes is

- a)  $-25.5 \text{ rad/s}^2$     b)  $-29.5 \text{ rad/s}^2$     c)  $-33.5 \text{ rad/s}^2$     d)  $-45.5 \text{ rad/s}^2$

427. A bomb dropped from an aeroplane explodes in air. Its total

- a) Momentum decreases    b) Kinetic increases    c) Kinetic energy increases    d) Kinetic energy decreases

428. A disc is rolling (without slipping) on a horizontal surface  $C$  is its centre and  $Q$  and  $P$  are two points equidistant from  $C$ . Let  $v_P, v_Q$  and  $v_C$  be the magnitude of velocities of points  $P, Q$  and  $C$  respectively, then

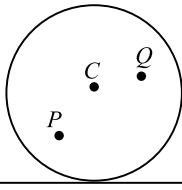

- a)  $v_Q > v_C > v_P$     b)  $v_Q < v_C < v_P$     c)  $v_Q = v_P, v_C = \frac{1}{2}v_P$     d)  $v_Q < v_C > v_P$

429. Two balls each of mass  $m$  are placed on the vertices  $A$  and  $B$  of an equilateral triangle  $ABC$  of side  $1 \text{ m}$ . A ball of mass  $2m$  is placed at vertex  $C$ . The centre of mass of this system from vertex  $A$  (located at origin) is

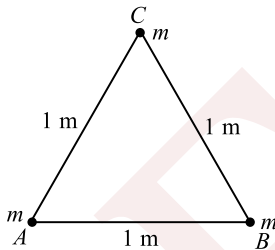

- a)  $(\frac{1}{2}m, \frac{1}{2}m)$     b)  $(\frac{1}{2}m, \sqrt{3}m)$     c)  $(\frac{1}{2}m, \frac{\sqrt{3}}{4}m)$     d)  $(\frac{\sqrt{3}}{4}m, \frac{\sqrt{3}}{4}m)$

430. A uniform heavy disc is rotating at constant angular velocity  $\omega$  about a vertical axis through its centre and perpendicular to the plane of the disc. Let  $L$  be its angular momentum. A lump of plasticine is dropped vertically on the disc and sticks to it. Which will be constant

- a)  $\omega$     b)  $\omega$  and  $L$  both    c)  $L$  only    d) Neither  $\omega$  nor  $L$

431. If a bullet is fired from a gun, then

- a) The mechanical energy of bullet-gun system remains constant    b) The mechanical energy is converted into non-mechanical energy    c) The mechanical energy may be conserved    d) The non-mechanical energy is converted into mechanical energy

432. A diver in a swimming pool bends his head before diving, because it

- a) Decreases his moment of inertia    b) Decreases his angular velocity    c) Increases his moment of inertia    d) Increases his linear velocity

433. Moment of inertia of a thin circular disc of mass  $M$  and radius  $R$  about any diameter is



- a)  $\frac{MR^2}{4}$                       b)  $\frac{MR^2}{2}$                       c)  $MR^2$                       d)  $2MR^2$
434. Two balls of masses 2g and 6g are moving with KE in the ratio of 3:1. What is the ratio of their linear momenta?  
a) 1 : 1                      b) 2 : 1                      c) 1 : 2                      d) None of these
435. If the torque of the rotational motion be zero, then the constant quantity will be  
a) Angular momentum                      b) Linear momentum                      c) Angular acceleration                      d) Centripetal acceleration
436. A door 1.6 m wide requires a force of 1 N to be applied at the free end to open or close it. The force that is required at a point 0.4 m distance from the hinges for opening or closing the door is  
a) 1.2 N                      b) 3.6 N                      c) 2.4 N                      d) 4 N
437. A hemispherical bowl of radius  $R$  is kept on a horizontal table. A small sphere of radius  $r$  ( $r \ll R$ ) is placed at the highest point at the inside of the bowl and let go. The sphere rolls without slipping. Its velocity at the lowest point is  
a)  $\sqrt{5gR/7}$                       b)  $\sqrt{3gR/2}$                       c)  $\sqrt{4gR/3}$                       d)  $\sqrt{10gR/7}$
438. What is the magnitude of torque acting on a particle moving in the  $xy$ -plane about the origin if its angular momentum is  $4.0\sqrt{t} \text{ kg} - \text{m}^2\text{s}^{-1}$ ?  
a)  $8t^{3/2}$                       b)  $4.0/\sqrt{t}$                       c)  $2.0/\sqrt{t}$                       d)  $3/2\sqrt{t}$
439. Particle of mass  $4m$  which is at rest explodes into three fragments. Two of the fragments each of mass  $m$  are found to move with a speed  $v$  each in mutually perpendicular directions. Calculate the energy released in the process of explosion.  
a)  $\frac{1}{2}mv^2$                       b)  $\frac{3}{2}mv^2$                       c)  $\frac{5}{2}mv^2$                       d)  $3mv^2$
440. If linear velocity is constant then angular velocity is proportional to  
a)  $1/r$                       b)  $1/r^2$                       c)  $1/r^3$                       d)  $1/r^5$
441. Four identical spheres each of mass  $M$  and radius 10 cm each are placed on a horizontal surface touching one another so that their centres are located at the corners of a square of side 20 cm. What is the distance of their centre of mass from centre of any sphere?  
a) 5 cm                      b) 10 cm                      c) 20 cm                      d)  $10\sqrt{2}$  cm
442. The moment of inertia of a thin uniform rod of mass  $M$  and length  $L$  about an axis passing through its midpoint and perpendicular to its length is  $I_0$ . Its moment of inertia about an axis passing through one of its ends and perpendicular to its length is  
a)  $I_0 + ML^2$                       b)  $I_0 + \frac{ML^2}{2}$                       c)  $I_0 + \frac{ML^2}{4}$                       d)  $I_0 + 2ML^2$
443. If the polar ice caps melt suddenly  
a) The length of day will be more than 24 hours                      b) The length of the day will less than 24 hours                      c) The length of the day will remain same as 24 hours                      d) The length of the day will become more than 24 hours initially and then becomes equal to 24 hours
444. If all of a sudden the radius of the earth decreases, then  
a) The angular momentum of the earth will become greater than that of the sun                      b) The angular speed of the earth will increase                      c) The periodic time of the earth will increase                      d) The energy and angular momentum will remain constant



445. The moments of inertia of two freely rotating bodies  $A$  and  $B$  are  $I_A$  and  $I_B$  respectively.  $I_A > I_B$  and their angular momenta are equal. If  $K_A$  and  $K_B$  are their kinetic energies, then  
 a)  $K_A = K_B$       b)  $K_A \neq K_B$       c)  $K_A < K_B$       d)  $K_A = 2K_B$
446. A body in equilibrium may not have  
 a) Momentum      b) Velocity      c) Acceleration      d) Kinetic energy
447. A hollow sphere of diameter  $0.2\text{ m}$  and mass  $2\text{ kg}$  is rolling on an inclined plane with velocity  $v = 0.5\text{ m/s}$ . The kinetic energy of the sphere is  
 a)  $0.1\text{ J}$       b)  $0.3\text{ J}$       c)  $0.5\text{ J}$       d)  $0.42\text{ J}$
448. A motor is rotating at a constant angular velocity of  $600\text{ rpm}$ . The angular displacement per second is  
 a)  $\frac{3}{50\pi}\text{ rad}$       b)  $\frac{3\pi}{50}\text{ rad}$       c)  $\frac{25\pi}{3}\text{ rad}$       d)  $\frac{50\pi}{3}\text{ rad}$
449. A pulley of radius  $2\text{ m}$  is rotating about its axis by a force  $F = (20t - 5t^2)\text{ N}$  (where  $t$  is measured in seconds) applied tangentially. If the moment of inertia of the pulley about its axis rotation is  $10\text{ kgm}^2$ , the number of rotations made by the pulley before its direction of motion if reserved, is  
 a) More than 3 but less than 6      b) More than 6 but less than 9      c) More than 9      d) Less than 3
450. The moment of inertia about an axis of a body which is rotating with angular velocity  $1\text{ rads}^{-1}$  is numerically equal to  
 a) One-fourth of its rotational kinetic energy      b) Half of the rotational kinetic energy      c) Rotational kinetic energy      d) Twice the rotational kinetic energy
451. A solid sphere rolls down without slipping on an inclined plane at angle  $60^\circ$  over a distance of  $10\text{ m}$ . the acceleration (in  $\text{ms}^{-2}$ ) is  
 a) 4      b) 5      c) 6      d) 7
452. An example of inelastic collision is  
 a) Scattering of  $\alpha$ -particle from a nucleus      b) Collision of ideal gas molecules      c) Collision of two steel balls lying on a frictionless table      d) Collision of a bullet with a wooden block
453. In an orbital motion, the angular momentum vector is  
 a) Along the radius vector      b) Parallel to the linear momentum      c) In the orbital planed) Perpendicular to the orbital plane
454. A ring of mass  $10\text{ kg}$  and diameter  $0.4\text{ m}$  is rotated about its axis. If it makes  $2100$  revolutions per minute, then its angular momentum will be  
 a)  $44\text{ kg} \times \text{m}^2/\text{s}$       b)  $88\text{ kg} \times \text{m}^2/\text{s}$       c)  $4.4\text{ kg} \times \text{m}^2/\text{s}$       d)  $0.4\text{ kg} \times \text{m}^2/\text{s}$
455. A marble and a cube have the same mass starting from rest, the marble rolls and the cube slides down a frictionless ramp. When they arrive at the bottom, the ratio of speed of the cube to the centre of mass and speed of the marble is  
 a)  $7 : 5$       b)  $\sqrt{7} : \sqrt{5}$       c)  $\sqrt{2} : 1$       d)  $5 : 2$
456. Two solid discs of radii  $r$  and  $2r$  roll from the top of an inclined plane without slipping. Then  
 a) The bigger disc will reach the horizontal level first      b) The smaller disc will reach the horizontal level first      c) The time difference of reaching of the discs at the horizontal level will depend on the inclination of the plane      d) Both the discs will reach at the same time



457. A thin horizontal circular disc is rotating about a vertical axis passing through its centre. An insect is at rest at a point near the rim of the disc. The insect now moves along a diameter of the disc to reach its other end. During the journey of the insect, the angular speed of the disc  
 a) Continuously decreases      b) Continuously increases      c) first increases and then decreases      d) Remains unchanged
458. If there is change of angular momentum from  $J$  to  $5J$  in 5 s, then the torque is  
 a)  $\frac{3J}{5}$       b)  $\frac{4J}{5}$       c)  $\frac{5J}{4}$       d) None of these
459. Two boys of masses 10 kg and 8 kg are moving along a vertical rope, the former climbing up with acceleration of  $2 \text{ ms}^{-1.2}$  while later coming down with uniform velocity of  $2 \text{ ms}^{-1}$ . Then tension in rope at fixed support will be (Take  $g = 10 \text{ ms}^{-2}$ )  
 a) 200 N      b) 120 N      c) 180 N      d) 160 N
460. Angular momentum of the particle rotating with a central force is constant due to  
 a) Constant force      b) Constant linear momentum      c) Zero torque      d) Constant torque
461. The mass of the earth is increasing at the rate of 1 part in  $5 \times 10^{19}$  per day by the attraction of meteors falling normally on the earth's surface. Assuming that the density of earth is uniform, the rate of change of the period of rotation of the earth is  
 a)  $2.0 \times 10^{-20}$       b)  $2.66 \times 10^{-19}$       c)  $4.33 \times 10^{-18}$       d)  $5.66 \times 10^{-17}$
462. In a one dimensional collision between two identical particles  $A$  and  $B$ ,  $B$  is stationary and  $A$  has momentum  $p$  before impact. During impact  $B$  gives an impulse  $J$  to  $A$ . Then coefficient of restitution between the two is  
 a)  $\frac{2J}{p} - 1$       b)  $\frac{2J}{p} + 1$       c)  $\frac{J}{p} + 1$       d)  $\frac{J}{p} - 1$
463. An annular ring with inner and outer radii  $R_1$  and  $R_2$  is rolling without slipping with a uniform angular speed. The ratio of the forces experienced by the two particles situated on the inner and outer parts of the ring,  $\frac{F_1}{F_2}$  is  
 a)  $\frac{R_2}{R_1}$       b)  $\left(\frac{R_1}{R_2}\right)^2$       c) 1      d)  $\frac{R_1}{R_2}$
464. A thin circular ring of mass  $M$  and radius  $r$  is rotating about its axis with a constant angular velocity  $\omega$ . Four objects each of mass  $m$ , are kept gently to the opposite ends of two perpendicular diameters of the ring. The angular velocity of the ring will be  
 a)  $\frac{M\omega}{M + 4m}$       b)  $\frac{(M + 4m)\omega}{M}$       c)  $\frac{(M - 4m)\omega}{M + 4m}$       d)  $\frac{M\omega}{4m}$
465. Consider a uniform square of this plate of side  $a$  and mass  $m$ . The moment of inertia of this plate about an axis perpendicular to its plane and passing through one of its corners is  
 a)  $5/6 ma^2$       b)  $1/12 ma^2$       c)  $7/12 ma^2$       d)  $2/3 ma^2$
466. The radius of a rotating disc is suddenly reduced to half without any change in its mass. Then its angular velocity will be  
 a) Four times      b) Double      c) Half      d) Unchanged
467. Look at the drawing given in the figure, which has been drawn with ink of uniform line-thickness. The mass of ink used to draw each of the two inner circles, and each of the two line segments is  $m$ . The mass of ink used to draw the outer circle is  $6m$ . The coordinates of the centres of the different parts are : outer circle  $(0, 0)$  left inner circle  $(-a, a)$ , right inner circle  $(a, a)$  vertical line  $(0, 0)$  and horizontal line  $(0, -a)$ . The  $y$ -coordinate of the centre of mass of the ink in the drawing is



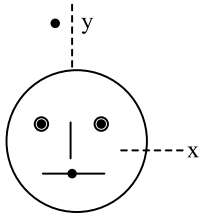

- a)  $\frac{a}{10}$                       b)  $\frac{a}{8}$                       c)  $\frac{a}{12}$                       d)  $\frac{a}{3}$

468.  $ABC$  is an equilateral triangle with  $O$  as its centre.  $\vec{F}_1, \vec{F}_2$  and  $\vec{F}_3$  represent three forces acting along the sides  $AB, BC$  and  $AC$  respectively. If the total torque about  $O$  is zero then the magnitude of  $\vec{F}_3$  is

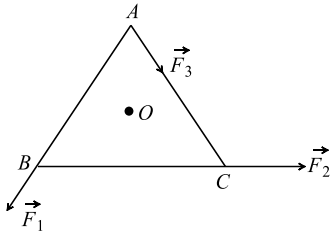

- a)  $F_1 + F_2$                       b)  $F_1 - F_2$                       c)  $\frac{F_1 + F_2}{2}$                       d)  $2(F_1 + F_2)$

469. A ball of mass  $m$  moving with velocity  $v$  collides with another ball of mass  $2m$  and sticks to it. The velocity  $v$  collides with of the final system is

- a)  $v/3$                       b)  $v/2$                       c)  $2v$                       d)  $3v$

470. A disc of moment of inertia  $5 \text{ kg} \cdot \text{m}^2$  is acted upon by a constant torque of  $40 \text{ Nm}$ . Starting from rest the time taken by it to acquire an angular velocity of  $24 \text{ rads}^{-1}$  is

- a)  $3 \text{ s}$                       b)  $4 \text{ s}$                       c)  $2.5 \text{ s}$                       d)  $120 \text{ s}$

471. A circular disc of mass  $0.41 \text{ kg}$  and radius  $10 \text{ m}$  rolls without slipping with a velocity of  $2 \text{ m/s}$ . The total kinetic energy of disc is

- a)  $0.41 \text{ J}$                       b)  $1.23 \text{ J}$                       c)  $0.82 \text{ J}$                       d)  $2.4 \text{ J}$

472. If rotational kinetic energy is 50% of translational kinetic energy, then the body is

- a) Ring                      b) Cylinder                      c) Hollow sphere                      d) Solid sphere

473. When a ceiling fan is switched off, its angular velocity falls to half while it makes 36 rotations. How many rotations will it make before coming to rest?

- a) 24                      b) 36                      c) 18                      d) 12

474. Two solid cylinders  $P$  and  $Q$  of same mass and same radius start rolling down a fixed inclined plane from the same height at the same time. Cylinder  $P$  has most of its mass concentrated near its surface, while  $Q$  has most of its mass concentrated near the axis. Which statement (s) is (are) correct

- |   |  |  |  |
|---|--|--|--|
| a) Both cylinders $P$ and $Q$ reach the ground at the same time | b) Cylinder $P$ has larger linear acceleration than cylinder $Q$ | c) Both cylinder $P$ and $Q$ reaches the ground with same translational kinetic energy | d) Cylinder $Q$ reaches the ground with larger angular speed |
|---|--|--|--|

475. Two carts on horizontal straight rails are pushed apart by an explosion of a powder charge  $Q$  placed between the carts. Suppose the coefficient of friction between carts and rails are identical. If the  $200 \text{ kg}$  cart travels a distance of  $36 \text{ m}$  and stops, the distance covered by the cart weighing  $300 \text{ kg}$  is

- a)  $32 \text{ m}$                       b)  $24 \text{ m}$                       c)  $16 \text{ m}$                       d)  $12 \text{ m}$

476. The moment of inertia of thin circular disc about an axis passing through its centre and perpendicular to its plane is  $I$ . Then, the moment of inertia of the disc about an axis parallel to its diameter and touching the edge of the rim is



- a)  $I$                       b)  $2I$                       c)  $\frac{3}{2}I$                       d)  $\frac{5}{2}I$
477. A sphere of mass  $50\text{ g}$  and diameter  $20\text{ cm}$  rolls without slipping with a velocity of  $5\text{ cm/sec}$ . Its total kinetic energy is  
a)  $625\text{ erg}$                       b)  $250\text{ erg}$                       c)  $875\text{ erg}$                       d)  $875\text{ joule}$
478. Two persons of masses  $55\text{ kg}$  and  $65\text{ kg}$  respectively, are at the opposite ends of a boat. The length of the boat is  $3.0\text{ m}$  and weighs  $100\text{ kg}$ . The  $55\text{ kg}$  man walks up to the  $65\text{ kg}$  man and sits with him. If the boat is in still water the centre of mass of the system shifts by  
a)  $3.0\text{ m}$                       b)  $2.3\text{ m}$                       c) Zero                      d)  $0.75\text{ m}$
479. Two particles of masses  $m_1$  and  $m_2$  are connected by a rigid massless rod of length  $r$  to constitute a dumb-bell which is free to move in the plane. The moment of inertia of the dumb-bell about an axis perpendicular to the plane passing through the centre of mass is  
a)  $\frac{m_1 m_2 r^2}{m_1 + m_2}$                       b)  $(m_1 + m_2)r^2$                       c)  $\frac{m_1 m_2 r^2}{m_1 - m_2}$                       d)  $(m_1 - m_2)r^2$
480. Three identical thin rods each of length  $l$  and mass  $M$  are joined together to form a letter  $H$ . What is the moment of inertia of the system about one of the sides of  $H$ ?  
a)  $M\frac{l^2}{4}$                       b)  $M\frac{l^2}{3}$                       c)  $2\frac{Ml^2}{3}$                       d)  $4\frac{Ml^2}{3}$
481. A circular thin disc of mass  $2\text{ kg}$  has a diameter  $0.2\text{ m}$ . Calculate its moment of inertia about an axis passing through the edge and perpendicular to the plane of the disc (in  $\text{kg} - \text{m}^2$ )  
a)  $0.01$                       b)  $0.03$                       c)  $0.02$                       d)  $3$
482. Two bodies of mass  $1\text{ kg}$  and  $3\text{ kg}$  have position vectors  $\hat{i} + 2\hat{j} + \hat{k}$  and  $-3\hat{i} - 2\hat{j} + \hat{k}$ , respectively. The centre of mass of this system has a position vector  
a)  $-2\hat{i} + 2\hat{k}$                       b)  $-2\hat{i} - \hat{j} + \hat{k}$                       c)  $2\hat{i} - \hat{j} - \hat{k}$                       d)  $-\hat{i} + \hat{j} + \hat{k}$
483. A circular disc of mass  $0.41\text{ kg}$  and radius  $10\text{ m}$  rolls without slipping with a velocity of  $2\text{ ms}^{-1}$ . The total kinetic energy of disc is  
a)  $0.41\text{ J}$                       b)  $1.23\text{ J}$                       c)  $0.82\text{ J}$                       d)  $2.45\text{ J}$
484. Two bodies  $A$  and  $B$  have masses  $M$  and  $m$  respectively, where  $M > m$  and they are at a distance  $d$  apart. Equal force is applied to them so that they approach each other. The position where they hit each other is  
a) Nearer to  $B$                       b) Nearer to  $A$                       c) At equal distance from  $A$  and  $B$                       d) Cannot be decided
485. The moment of inertia of a sphere of radius  $R$  and mass  $M$  about a tangent to the sphere is  
a)  $MR^2$                       b)  $\frac{2}{5}MR^2$                       c)  $\frac{12}{5}MR^2$                       d)  $\frac{7}{5}MR^2$
486. A cockroach is moving with velocity  $v$  in anticlockwise direction on the rim of a disc of radius  $R$  of mass  $m$ . The moment of inertia of the disc about the axis is  $I$  and it is rotating in clockwise direction with an angular velocity  $\omega$ . If the cockroach stops, the angular velocity of the disc will be  
a)  $\frac{I\omega}{I + mR^2}$                       b)  $\frac{I\omega + mvR}{I + mR^2}$                       c)  $\frac{I\omega - mvR}{I + mR^2}$                       d)  $\frac{I\omega - mvR}{I}$
487. Moment of inertia of a ring of mass  $M$  and radius  $R$  about an axis passing through the centre and perpendicular to the plane is  $I$ . What is the moment of inertia about its diameter  
a)  $I$                       b)  $\frac{I}{2}$                       c)  $\frac{I}{\sqrt{2}}$                       d)  $I + MR^2$
488. A thin metal disc of radius  $0.25\text{ m}$  and mass  $2\text{ kg}$  starts from rest and rolls down an inclined plane. If its rotational kinetic energy is  $4\text{ J}$  at the foot of the inclined plane, then its linear velocity at the same point is  
a)  $1.2\text{ ms}^{-1}$                       b)  $2\sqrt{2}\text{ ms}^{-1}$                       c)  $20\text{ ms}^{-1}$                       d)  $2\text{ ms}^{-1}$

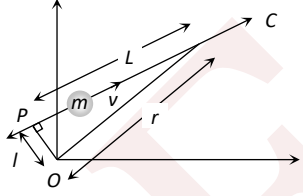
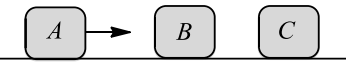

489. A hoop of mass  $M$  and radius  $R$  is suspended to a peg in a wall. Its moment of inertia about the peg is  
 a)  $2MR^2$                       b)  $MR^2$                       c)  $\frac{MR^2}{2}$                       d)  $\frac{3}{2}MR^2$
490. In the  $HCl$  molecule, the separation between the nuclei of the two atoms is about  $1.27 \text{ \AA}$  ( $1 \text{ \AA} = 10^{-10}m$ ). The approximate location of the centre of mass of the molecule, assuming the chlorine atom to be about 35.5 times massive as hydrogen is  
 a)  $1 \text{ \AA}$                       b)  $2.5 \text{ \AA}$                       c)  $1.24 \text{ \AA}$                       d)  $1.5 \text{ \AA}$
491. A sphere of mass  $m$  and radius  $r$  rolls on a horizontal plane without slipping with the speed  $u$ . Now, if it rolls up vertically, the maximum height it would attain will be  
 a)  $\frac{3u^2}{4g}$                       b)  $\frac{5u^2}{2g}$                       c)  $\frac{7u^2}{10g}$                       d)  $\frac{u^2}{2g}$
492. If a hollow cylinder and a solid cylinder are allowed to roll down an inclined plane, which will take more time to reach the bottom  
 a) Hollow cylinder    b) Solid cylinder    c) Same for both    d) One whose density is more
493. Analogue of mass in rotational motion is  
 a) Moment of inertia    b) Angular momentum    c) Torque    d) None of these
494. Moment of inertia of an object does not depend upon  
 a) Mass of object    b) Mass distribution    c) Angular velocity    d) Axis of rotation
495. A uniform disc of mass 2 kg and radius 15 cm is revolving around the central axis by  $4 \text{ rads}^{-1}$ . The linear momentum of disc will be  
 a)  $1.2 \text{ kg} - \text{ms}^{-1}$     b)  $1.0 \text{ kg} - \text{ms}^{-1}$     c)  $0.6 \text{ kg} - \text{ms}^{-1}$     d) None of these
496. A particle of mass  $m$  moves along line  $PC$  with velocity  $v$  as shown. What is the angular momentum of the particle about  $O$
- 
- a)  $mvL$                       b)  $mv l$                       c)  $mvr$                       d) Zero
497. A sphere of mass  $10 \text{ kg}$  and radius  $0.5 \text{ m}$  rotates about a tangent. The moment of inertia of the solid sphere is  
 a)  $5 \text{ kg} \cdot \text{m}^2$                       b)  $2.7 \text{ kg} \cdot \text{m}^2$                       c)  $3.5 \text{ kg} \cdot \text{m}^2$                       d)  $4.5 \text{ kg} \cdot \text{m}^2$
498. The angular momentum of a particle describing uniform circular motion in  $L$ . If its kinetic energy is halved and angular velocity doubled, its new angular momentum is  
 a)  $4L$                       b)  $\frac{L}{4}$                       c)  $\frac{L}{2}$                       d)  $2L$
499. Three identical blocks  $A$ ,  $B$  and  $C$  are placed on horizontal frictionless surface. The blocks  $A$  and  $C$  are at rest. But  $A$  is approaching towards  $B$  with a speed  $10 \text{ ms}^{-1}$ . The coefficient of restitution for all collisions is 0.5. The speed of the block  $C$  just after collision is
- 
- a)  $5.6 \text{ ms}^{-1}$                       b)  $6 \text{ ms}^{-1}$                       c)  $8 \text{ ms}^{-1}$                       d)  $10 \text{ ms}^{-1}$
500. A bomb of mass 9 kg explodes into two pieces of masses 3 kg and 6 kg. The velocity of mass 3 kg is  $16 \text{ ms}^{-1}$ . The kinetic energy of mass 6 kg in joule is  
 a) 96                      b) 384                      c) 192                      d) 768



501. A ring solid sphere and a disc are rolling down from the top of the same height, then the sequence to reach on surface is  
 a) Ring, disc, sphere b) Sphere, disc, ring c) Disc, ring, sphere d) Sphere, ring, disc
502. A thick uniform bar lies on a frictionless horizontal surface and is free to move in any way on the surface. It mass is 0.16 kg and length is 1.7 m. Two particles each of mass 0.08 kg are moving on the same surface and towards the bar in the direction perpendicular to the bar, one with a velocity of  $10 \text{ ms}^{-1}$  and other with velocity  $6 \text{ ms}^{-1}$ . If collision between particles and bar is completely inelastic, both particles strike with the bar simultaneously. The velocity of centre of mass after collision is  
 a)  $2 \text{ ms}^{-1}$  b)  $4 \text{ ms}^{-1}$  c)  $10 \text{ ms}^{-1}$  d)  $167 \text{ ms}^{-1}$
503. If the radius of the earth contracts to half of its present day value without change in mass, then the length of the day will be  
 a) 24 h b) 48 h c) 6 h d) 12 h
504. A body of mass  $M$  moving with velocity  $v \text{ ms}^{-1}$  suddenly breaks into two pieces. One part having mass  $M/4$  remains stationary. The velocity of the other part will be  
 a)  $v$  b)  $2v$  c)  $\frac{3v}{4}$  d)  $\frac{4v}{3}$
505. A non-zero external force acts on a systems of particles. The velocity and acceleration of the centre of mass are found to be  $v_0$  and  $a_0$  at an instant  $t$ . It is possible that  
 a)  $v_0 = 0, a_0 = 0$  b)  $v_0 = 0, a_0 \neq 0$  c)  $v_0 \neq 0, a_0 = 0$  d)  $v_0 \neq 0, a_0 \neq 0$
506. A rod of length  $L$  and mass  $M$  is bent to form a semi-circular ring as shown in figure. The moment of inertia about  $XY$  is

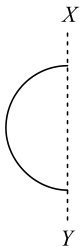

- a)  $\frac{ML^2}{2\pi^2}$  b)  $\frac{ML^2}{\pi^2}$  c)  $\frac{ML^2}{4\pi^2}$  d)  $\frac{2ML^2}{\pi^2}$

507. In a bicycle the radius of rear wheel is twice the radius of front wheel. If  $r_F$  and  $r_r$  are the radius,  $v_F$  and  $v_r$ , are speeds of top most points of wheel, then  
 a)  $v_r = 2 v_F$  b)  $v_F = 2 v_r$  c)  $v_F = v_r$  d)  $v_F > v_r$
508. Consider a body, shown in figure, consisting of two identical balls, each of mass  $M$  connected by a light rigid rod. If an impulse  $J = Mv$  is imparted to the body at one of its ends, what would be its angular velocity?

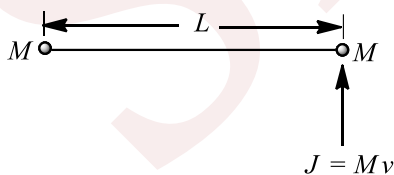

- a)  $v/L$  b)  $2v/L$  c)  $v/3L$  d)  $v/4L$
509. A drum of radius  $R$  and mass  $M$ , rolls down without slipping along an inclined plane of angle  $\theta$ . The frictional force  
 a) Converts translational energy to rotational energy  
 b) Dissipates energy as heat  
 c) Decreases the rotational motion  
 d) Decreases the rotational and translational motion

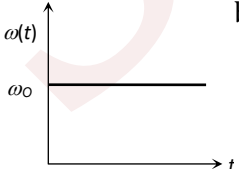
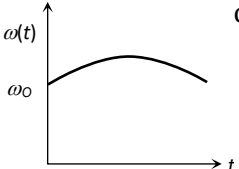
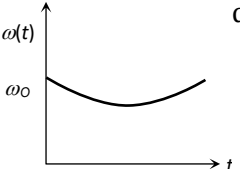
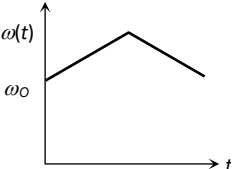

510. A disc of mass 2 kg and radius 0.2 m is rotating with angular velocity  $30 \text{ rads}^{-1}$ . What is angular velocity, if a mass of 0.25 kg is put on periphery of the disc?  
 a)  $24 \text{ rads}^{-1}$       b)  $36 \text{ rads}^{-1}$       c)  $15 \text{ rads}^{-1}$       d)  $26 \text{ rads}^{-1}$
511. A uniform rod of length  $8a$  and mass  $6m$  lies on a smooth horizontal surface. Two point masses  $m$  and  $2m$  moving in the same plane with speed  $2v$  and  $v$  respectively strike the rod perpendicular at distances  $a$  and  $2a$  from the mid point of the rod in the opposite directions and stick to the rod. The angular velocity of the system immediately after the collision is  
 a)  $\frac{6v}{32a}$       b)  $\frac{6v}{33a}$       c)  $\frac{6v}{40a}$       d)  $\frac{6v}{41a}$
512. The angle turned by a body undergoing circular motion depends on time as  $\theta = \theta_0 + \theta_1 t + \theta_2 t^2$ . Then the angular acceleration of the body is  
 a)  $\theta_1$       b)  $\theta_2$       c)  $2\theta_1$       d)  $2\theta_2$
513. Consider a system of two particles having masses  $m_1$  and  $m_2$ . If the particle of mass  $m_1$  is pushed towards the centre of mass of particles through a distance  $d$ , by what distance would be particle of mass  $m_2$  move so as to keep the centre of mass of particles at the original position  
 a)  $\frac{m_1}{m_1 + m_2} d$       b)  $\frac{m_1}{m_2} d$       c)  $d$       d)  $\frac{m_2}{m_1} d$
514. A solid sphere rolls down without slipping on an inclined plane at angle  $60^\circ$  over a distance of 10 m. The acceleration (in  $\text{ms}^{-2}$ ) is  
 a) 4      b) 5      c) 6      d) 7
515. The centre of mass of a system of three particles of masses  $1g$ ,  $2g$  and  $3g$  is taken as the origin of a coordinate system. The position vector of a fourth particle of mass  $4g$  such that the centre of mass of the four particle system lies at the point  $(1, 2, 3)$  is  $\alpha(\hat{i} + 2\hat{j} + 3\hat{k})$ , where  $\alpha$  is a constant. The value of  $\alpha$  is  
 a)  $\frac{10}{3}$       b)  $\frac{5}{2}$       c)  $\frac{1}{2}$       d)  $\frac{2}{5}$
516. Circular hole of radius 1 cm is cut off from a disc of radius 6 cm. The centre of hole is 3 cm from the centre of the disc. The position of centre of mass of the remaining disc from the centre of disc is  
 a)  $-\frac{3}{35} \text{ cm}$       b)  $\frac{3}{35} \text{ cm}$       c)  $\frac{3}{10} \text{ cm}$       d) None of these
517. A ball of mass  $m_1$  is moving with velocity  $v$ . It collides head on elastically with a stationary ball of mass  $m_2$ . The velocity of ball becomes  $v/3$  after collision. Then the value of the ratio  $\frac{m_2}{m_1}$  is  
 a) 1      b) 2      c) 3      d) 4
518. A circular platform is free to rotate in a horizontal plane about a vertical axis passing through its centre. A tortoise is sitting at the edge of the platform. Now, the platform is given an angular velocity  $\omega_0$ . When the tortoise moves along a chord of the platform with a constant velocity (with respect to the platform), the angular velocity of the platform  $\omega(t)$  will vary with time  $t$  as  
 a)       b)       c)       d) 
519. The rotational kinetic energy of a body is  $E$  and its moment of inertia is  $I$ . The angular momentum is  
 a)  $EI$       b)  $2\sqrt{EI}$       c)  $\sqrt{2EI}$       d)  $E/I$
520. Two spherical bodies of masses  $M$  and  $5M$  in free space with initial separation between their centres equal to  $12R$ . If they attract each other due to gravitational force only, then the distance covered by the smaller body just before collision is  
 a)  $2.5 R$       b)  $4.5 R$       c)  $7.5 R$       d)  $1.5 R$



521. Two bodies of mass  $M$  and  $m$  are moving with same kinetic energy. If they are stopped by same retarding force, then
- a) Both bodies cover same distance before coming to rest
- b) If  $M > m$ , the time taken to come to rest for body of mass  $M$  is more than that of body of mass  $m$
- c) If  $m > M$ , then body of mass  $m$  has more momentum than that of mass  $M$
- d) All of the above
522. Moment of inertia depends on
- a) Distribution of particles
- b) Mass
- c) Position of axis of rotation
- d) All of these
523. From a uniform wire, two circular loops are made (i)  $P$  of radius  $r$  and (ii)  $Q$  of radius  $nr$ . If the moment of inertia of  $Q$  about an axis passing through its centre and perpendicular to its plane is 8 times that of  $P$  about a similar axis, the value of  $n$  is (diameter of the wire is very much smaller than  $r$  or  $nr$ )
- a) 8
- b) 6
- c) 4
- d) 2
524. Two perfectly elastic objects  $A$  and  $B$  of identical mass are moving with velocities  $15 \text{ ms}^{-1}$  and  $10 \text{ ms}^{-1}$  respectively, collide along the direction of line joining them. Their velocities after collision are respectively
- a)  $10 \text{ ms}^{-1}, 15 \text{ ms}^{-1}$
- b)  $20 \text{ ms}^{-1}, 5 \text{ ms}^{-1}$
- c)  $0 \text{ ms}^{-1}, 25 \text{ ms}^{-1}$
- d)  $5 \text{ ms}^{-1}, 20 \text{ ms}^{-1}$
525. A wheel has a speed of 1200 revolutions per *minute* and is made to slow down at a rate of  $4 \text{ radians/s}^2$ . The number of revolutions it makes before coming to rest is
- a) 143
- b) 272
- c) 314
- d) 722
526. Three rods each of length  $L$  and mass  $M$  are placed along  $X, Y$  and  $Z$  axes in such a way that one end of each of the rod is at the origin. The moment of inertia of this system about  $Z$  axis is
- a)  $\frac{2ML^2}{3}$
- b)  $\frac{4ML^2}{3}$
- c)  $\frac{5ML^2}{3}$
- d)  $\frac{ML^2}{3}$
527. The diameter of a flywheel is increased by 1%. Increase in its moment of inertia about the central axis is
- a) 1%
- b) 0.5%
- c) 2%
- d) 4%
528. Consider the following two statements
- I. Linear momentum of a system of particles is zero.
- II. Kinetic energy of a system of particles is zero. Then
- a) I implies II and II implies I
- b) I does not imply II and II does not imply I
- c) I implies II but II does not imply I
- d) I does not imply II but II implies I
529. A thin uniform rod, pivoted at  $O$ , is rotating in the horizontal plane with constant angular speed  $\omega$ , as shown in the figure. At time,  $t = 0$ , a small insect starts from  $O$  and moves with constant speed  $v$  with respect to the rod towards the other end. It reaches the end of the rod at  $t = T$  and stops. The angular speed of the system remains  $\omega$  throughout. The magnitude of the torque ( $|\vec{\tau}|$ ) on the system about  $O$ , as a function of time is best represented by which plot

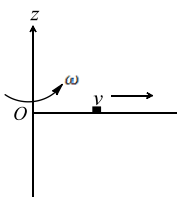

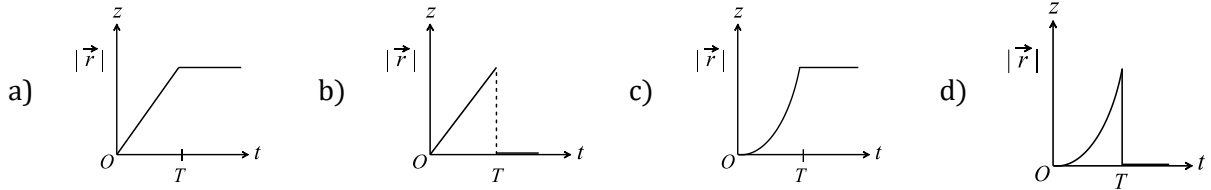

530. A cylinder of mass  $M$ , length  $L$  and radius  $R$ . If its moment of inertia about an axis passing through its centre and perpendicular to its axis is minimum, the ratio  $L/R$  must be equal to  
 a)  $3/2$       b)  $2/3$       c)  $\sqrt{2/3}$       d)  $\sqrt{3/2}$
531. By keeping moment of inertia of a body constant, if we double the time period, then angular momentum of body  
 a) Remains constant    b) Becomes half    c) Doubles    d) quadruples
532. A wheel is rotating at  $900 \text{ r.p.m.}$  about its axis. When the power is cut-off, it comes to rest in 1 minute. The angular retardation in  $\text{radian/s}^2$  is  
 a)  $\pi/2$       b)  $\pi/4$       c)  $\pi/6$       d)  $\pi/8$
533. A solid sphere is rotating in free space. If the radius of sphere is increased keeping mass same which one of the following will not be affected?  
 a) Angular velocity    b) Angular momentum    c) Moment of inertia    d) Rotational Kinetic energy
534. The motion of the centre of mass is the result of  
 a) Internal forces    b) External forces    c) Attractive forces    d) Repulsive forces
535. A particle of mass  $M$  is moving in a horizontal circle of radius  $R$  with uniform speed  $v$ . When it moves from one point to a diametrically opposite point, its  
 a) Momentum does not change    b) Momentum changes by  $2Mv$     c) KE changes by  $Mv^2$     d) None of the above
536. A stone of mass  $m$  tied to string of length  $l$  is rotating along a circular path with constant speed  $v$ . The torque on the stone is  
 a)  $mlv$       b)  $\frac{mv}{l}$       c)  $\frac{mv^2}{l}$       d) Zero
537. A child is standing with folded hands at the centre of a platform rotating about its central axis. The kinetic energy of the system is  $K$ . The child stretches his arms so that the moment of inertia of the system doubles. The kinetic energy of the system now is  
 a)  $2K$       b)  $\frac{K}{2}$       c)  $\frac{K}{4}$       d)  $4K$
538. The total kinetic energy of rolling solid sphere having translational velocity  $v$  is  
 a)  $\frac{7}{10}mv^2$     b)  $\frac{1}{2}mv^2$     c)  $\frac{2}{5}mv^2$     d)  $\frac{10}{7}mv^2$
539. A system consists of 3 particles each of mass  $m$  located at point  $(1, 1)$ ,  $(2, 2)$  and  $(3, 3)$ . The coordinates of the center of mass are  
 a)  $(6, 6)$       b)  $(3, 3)$       c)  $(1, 1)$       d)  $(2, 2)$
540. Find the velocity of centre of the system shown in the figure.

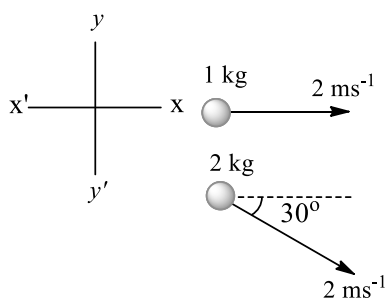

- a)  $\left(\frac{2+2\sqrt{3}}{3}\right)\hat{i} - \frac{2}{3}\hat{j}$     b)  $4\hat{i}$     c)  $\left(\frac{2-2\sqrt{3}}{3}\right)\hat{i} - \frac{1}{3}\hat{j}$     d) None of these
541. A boy stands over the centre of a horizontal platform which is rotating freely with a speed of  $2 \text{ revolutions/sec}$  about a vertical axis through the centre of the platform and straight up through the boy. He holds  $2 \text{ kg}$  masses in each of his hands close to his body. The combined moment of inertia of the system is  $1 \text{ kg} \times \text{metre}^2$ . The boy now stretches his arms so as to hold the masses of inertia of the system increases to  $2 \text{ kg} \times \text{metre}^2$ . The kinetic energy of the system in the latter case as compared with that in the previous case will
- a) Remains unchanged    b) Decrease    c) Increase    d) Remains uncertain
542. The moment of inertia of a metre scale of mass  $0.6 \text{ kg}$  about an axis perpendicular to the scale and located at the  $20 \text{ cm}$  position on the scale in  $\text{kg m}^2$  is (Breadth of the scale is negligible)
- a)  $0.074$     b)  $0.104$     c)  $0.148$     d)  $0.208$
543. A wheel of moment of inertia  $5 \times 10^{-3} \text{ kg} - \text{m}^2$  is making  $20$  revolutions per second. It is stopped in  $20$  seconds, then the angular retardation is
- a)  $\pi \text{ radian/sec}^2$     b)  $2\pi \text{ radian/sec}^2$     c)  $4\pi \text{ radian/sec}^2$     d)  $8\pi \text{ radian/sec}^2$
544. Two uniform thin rods each of mass  $M$  and length  $l$  are placed along  $X$  and  $Y$  axis with one end of each at the origin. Moment of inertia of the system about  $Z$ -axis is
- a)  $\frac{3}{2} Ml^2$     b)  $\frac{2}{3} Ml^2$     c)  $2Ml^2$     d) None of these
545. A body is dropped and observed to bounce a height greater than the dropping height. Then
- a) The collision is elastic    b) There is additional source of energy during collision    c) It is not possible    d) This type of phenomenon does not occur in nature
546. The masses of five balls at rest and lying at equal distances in a straight line are in geometrical progression with ratio  $2$  and their coefficients of restitution are each  $2/3$ . If the first ball be started towards the second with velocity  $u$ , then the velocity communicated to 5th ball is
- a)  $\frac{5}{9}u$     b)  $\left(\frac{5}{9}\right)^2 u$     c)  $\left(\frac{5}{9}\right)^3 u$     d)  $\left(\frac{5}{9}\right)^4 u$
547. A body moves with constant velocity  $v$  in a straight line parallel to  $x$ - axis. The angular momentum with respect to origin is
- a) Zero    b) Constant    c) Continuously increases    d) Continuously decrease
548. A radioactive nucleus of mass number  $A$ , initially at rest, emits an  $\alpha$ -particle with a speed  $v$ . What will be the recoil speed of the daughter nucleus?
- a)  $\frac{2v}{(A-4)}$     b)  $\frac{2v}{(A+4)}$     c)  $\frac{4v}{(A-4)}$     d)  $\frac{4v}{(A+4)}$
549. Two identical masses  $A$  and  $B$  are hanging stationary by a light pulley (shown in the figure). A shell  $C$  moving upwards with velocity  $v$  collides with the block  $B$  and gets stick to it. Then



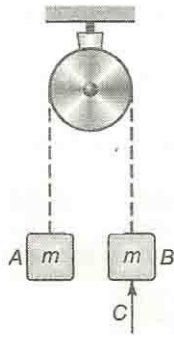

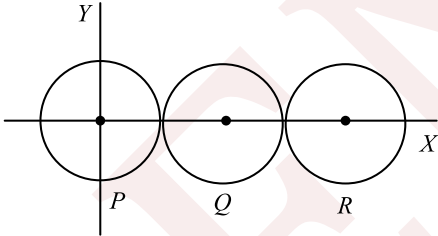
550. First string becomes slack and after some time becomes taut  
 a) First string becomes slack and after some time becomes taut  
 b) The momentum conservation principle is applicable to B and C  
 c) The string becomes taut only when down displacement of combined mass B and C is occurred  
 d) Both (a) and (b) are correct
550. A bomb travelling in a parabolic path under gravity, explodes in mid air. The centre of mass of fragments will move  
 a) Vertically upwards and then downwards  
 b) Vertically downwards  
 c) In an irregular path  
 d) In the parabolic path as the unexploded bomb would have travelled
551. Three identical spheres, each of mass 1 kg are kept as shown in figure below, touching each other, with their centers on a straight line. If their centres are marked P, Q, R respectively, the distance of centre of mass of the system from P is  
  
 a)  $\frac{PQ + PR + QR}{3}$   
 b)  $\frac{PQ + PR}{3}$   
 c)  $\frac{PQ + QR}{3}$   
 d)  $\frac{PR + QR}{3}$
552. Radius of gyration of a body depends upon  
 a) Mass and size of body  
 b) Mass distribution and axis of rotation  
 c) Size of body  
 d) Mass of body
553. A machine gun fires a steady stream of bullets at the rate of  $n$  per minute into a stationary target in which the bullets get beaded. If each bullet has a mass  $ma$  and arrive at the target with a velocity  $v$ , the average force on the target is  
 a)  $60 mnv$   
 b)  $\frac{60v}{mn}$   
 c)  $\frac{mnv}{60}$   
 d)  $\frac{mv}{60n}$
554. An angular ring with inner and outer radii  $R_1$  and  $R_2$  is roiling without slipping with a uniform angular speed. The ratio of the forces experienced by the two particles situated on the inner and outer parts of the ring.  $F_1/F_2$  is  
 a)  $R_1/R_2$   
 b) 1  
 c)  $\left(\frac{R_1}{R_2}\right)^2$   
 d)  $\frac{R_2}{R_1}$



555. Three rings each of mass  $M$  and radius  $R$  are arranged as shown in the figure. The moment of inertia of the system about  $YY'$  will be

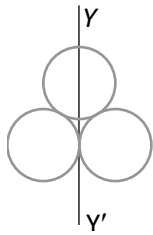

- a)  $3MR^2$                       b)  $\frac{3}{2}MR^2$                       c)  $5MR^2$                       d)  $\frac{7}{2}MR^2$
556. A shell is fired from a cannon with a velocity  $v$  at an angle  $\theta$  with the horizontal direction. At the highest point in its path, it explodes into two pieces, one retraces its path to the cannon and the speed of the other piece immediately after the explosion is
- a)  $3v \cos \theta$                       b)  $2v \cos \theta$                       c)  $\left(\frac{3}{2}\right)v \cos \theta$                       d)  $\left(\frac{\sqrt{3}}{2}\right)v \cos \theta$
557. Two homogeneous spheres  $A$  and  $B$  of masses  $m$  and  $2m$  having radii  $2a$  and  $a$  respectively are placed in touch. The distance of centre of mass from first sphere is
- a)  $a$                       b)  $2a$                       c)  $3a$                       d) None of these
558. A solid homogeneous sphere is moving on a rough horizontal surface partly rolling and partly sliding. During this kind of motion of the sphere
- a) Total kinetic energy is conserved                      b) The angular momentum of the sphere about the point of contact with the plane is conserved                      c) Only the rotational kinetic energy about the centre of mass is conserved                      d) Angular momentum about the centre of mass is conserved
559. A circular disc of radius  $R$  and thickness  $\frac{R}{6}$  has moment of inertia  $I$  about an axis passing through its centre and perpendicular to its plane. It is melted and recasted into a solid sphere. The moment of inertia of the sphere about its diameter as axis of rotation is
- a)  $I$                       b)  $\frac{2I}{8}$                       c)  $\frac{I}{5}$                       d)  $\frac{I}{10}$
560. Two circular iron discs are of the same thickness. The diameter of  $A$  is twice that of  $B$ . The moment of inertia of  $A$  as compared to that of  $B$  is
- a) Twice as large                      b) Four times as large                      c) 8 times as large                      d) 16 times as large
561. For the given uniform square lamina  $ABCD$ , whose centre is  $O$

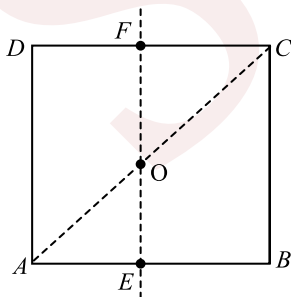

- a)  $\sqrt{2} I_{AC} = I_{EF}$                       b)  $I_{AD} = 4I_{EF}$                       c)  $I_{AC} = I_{EF}$                       d)  $I_{AC} = \sqrt{2} I_{EF}$
562. A ring of mass  $m$  and radius  $r$  is melted and then moulded into a sphere. The moment of inertia of the sphere will be



- a) More than that of the ring    b) Less than that of the ring    c) Equal to that of the ring    d) None of the above

563. Three rods of the same mass are placed as shown in figure. What will be the coordinates of centre of mass of the system?

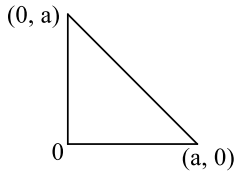

- a)  $\left[\frac{a}{2}, \frac{a}{2}\right]$     b)  $\left[\frac{a}{\sqrt{2}}, \frac{a}{\sqrt{2}}\right]$     c)  $[\sqrt{2}a, \sqrt{2}a]$     d)  $\left[\frac{a}{3}, \frac{a}{3}\right]$

564. A solid sphere is rolling without slipping on a horizontal surface. The ratio of its rotational kinetic energy to its translational kinetic energy is

- a)  $2/9$     b)  $2/7$     c)  $2/5$     d)  $7/2$

565. A wheel rotates with a constant acceleration of  $2.0 \text{ radian/sec}^2$ . If the wheel starts from rest the number of revolutions it makes in the first ten seconds will be approximately

- a) 8    b) 16    c) 24    d) 32

566. A nucleus reuptures into two nuclear parts which have their velocity ratio equal to 2:1. What will be the ratio of their nuclear size?

- a)  $2^{1/3}:1$     b)  $1:2^{1/3}$     c)  $3^{1/2}:1$     d)  $1:3^{1/2}$

567. A symmetrical body is rotating about its axis of symmetry, its moment of inertia about the axis of rotation being  $4 \text{ kg m}^2$  and its rate of rotation  $2 \text{ rev/s}$ . The angular momentum is

- a)  $1.257 \text{ kg m}^2\text{s}^{-1}$     b)  $12.57 \text{ kg m}^2\text{s}^{-1}$     c)  $13.57 \text{ kg m}^2\text{s}^{-1}$     d)  $20 \text{ kg m}^2\text{s}^{-1}$

568. Identify the correct statement for the rotational motion of a rigid body.

- |  |  |   |  |
|--|--|---|--|
| a) Individual particles of the body do not undergo accelerated motion. | b) The centre of mass of the body remains unchanged. | c) The centre of mass of the body moves uniformly in a circular path. | d) Individual particles and centre of mass the body undergo an accelerated motion. |
|--|--|---|--|

569. Of the two eggs which have identical sizes, shapes and weights, one is raw, and other is half boiled. The ratio between the moment of inertia of the raw to the half boiled egg about central axis is

- a) One    b) Greater than one    c) Less than one    d) Not comparable

570. A bullet of mass  $m$  is fired with a velocity of  $50 \text{ ms}^{-1}$  at an angle  $\theta$  with the horizontal. At the highest point of its trajectory, it collides head on with a bob of massless string of length  $l = 10/3m$  and gets embedded in the bob. After the collision, the string moves to an angle of  $120^\circ$ . What is the angle  $\theta$ ?

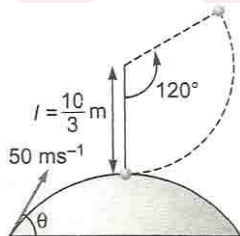

- a)  $\cos^{-1}\left(\frac{4}{5}\right)$     b)  $\cos^{-1}\left(\frac{5}{4}\right)$     c)  $\sin^{-1}\left(\frac{4}{5}\right)$     d)  $\sin^{-1}\left(\frac{5}{4}\right)$

571. If the torque is zero, what will be the value of angular momentum?



- a) Constant in magnitude but changing in direction      b) Changing in magnitude but constant in direction      c) Constant on both magnitude and direction      d) Zero

572. As a part of a maintenance inspection the compressor of a jet engine is made to spin according to the graph as shown. The number of revolutions made by the compressor during the test is

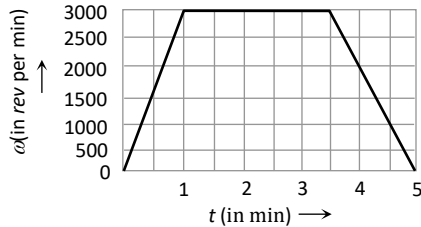

- a) 9000      b) 16570      c) 12750      d) 11250
573. If a force  $10\hat{i} + 15\hat{j} + 25\hat{k}$  acts on a system and gives an acceleration  $2\hat{i} + 3\hat{j} - 5\hat{k}$  to the centre of mass of the system, the mass of the system is  
a) 5 units      b)  $\sqrt{38}$  units      c)  $5\sqrt{38}$  units      d) Given data is not correct
574. Four similar point masses ( $m$  each) are symmetrically placed on the circumference of a disc of mass  $M$  and radius  $R$ . Moment of inertia of the system about an axis passing through centre  $O$  and perpendicular to the plane of the disc will be  
a)  $MR^2 + 4mR^2$       b)  $MR^2 + \frac{8}{5}mR^2$       c)  $mR^2 + 4MR^2$       d)  $\frac{MR^2}{2} + 4mR^2$
575. A point  $P$  on the rim of wheel is initially at rest and in contact with the ground. Find the displacement of the point  $P$  if the radius of the wheel is  $5m$  and the wheel rolls forward through half a revolution  
a)  $5m$       b)  $10m$       c)  $2.5m$       d)  $5(\sqrt{\pi^2 + 4})m$
576. The moment of inertia of a solid cylinder of mass  $M$  and radius  $R$  about a line parallel to the axis of the cylinder and lying on the surface of the cylinder is  
a)  $\frac{2}{5}MR^2$       b)  $\frac{3}{5}MR^2$       c)  $\frac{3}{2}MR^2$       d)  $\frac{5}{2}MR^2$
577. One quarter of the disc of mass  $m$  is removed. If  $r$  be the radius of the disc, the new moment of inertia is  
a)  $\frac{3}{2}mr^2$       b)  $\frac{mr^2}{2}$       c)  $\frac{3}{8}mr^2$       d) None of these
578. A uniform disc of mass  $M$  and radius  $R$  is mounted on a fixed horizontal axis. A block of mass  $m$  hangs from a massless string that is wrapped around the rim of the disc. The magnitude of the acceleration of the falling block ( $m$ ) is  
a)  $\frac{2M}{M+2m}g$       b)  $\frac{2m}{M+2m}g$       c)  $\frac{M+2m}{2M}g$       d)  $\frac{2M+m}{2M}g$
579. If ' $I$ ' is the moment of inertia of a body and ' $\omega$ ' is its angular velocity, then its rotational kinetic energy is  
a)  $\frac{1}{2} \times I\omega$       b)  $\frac{1}{2} \times I^2\omega$       c)  $\frac{1}{2} \times I\omega^2$       d)  $\frac{1}{2} \times I^2\omega^2$
580. A disc is rotating with an angular speed of  $\omega$ . If a child sits on it, which of the following is conserved  
a) Kinetic energy      b) Potential energy      c) Linear momentum      d) Angular momentum
581. From a circular disc of radius  $R$  and mass  $9M$ , a small disc of radius  $R/3$  is removed from the disc. The moment of inertia of the remaining disc about an axis perpendicular to the plane of the disc and passing through  $O$  is



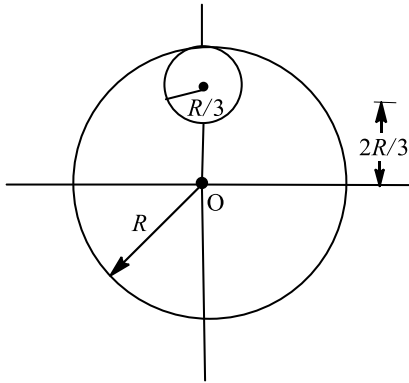

- a)  $4MR^2$       b)  $\frac{40}{9}MR^2$       c)  $10MR^2$       d)  $\frac{37}{9}MR^2$

582. A T joint is formed by two identical rods A and B each of mass  $m$  and length  $L$  in the  $XY$  plane as shown. Its moment of inertia about axis coinciding with A is

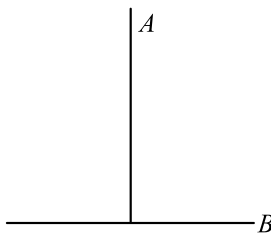

- a)  $\frac{2mL^2}{3}$       b)  $\frac{mL^2}{12}$       c)  $\frac{mL^2}{6}$       d) None of these

583. Where will be the centre of mass on combining two masses  $m$  and ( $M > m$ )

- a) Towards  $m$       b) Towards  $M$       c) Between  $m$  and  $M$       d) Anywhere

584. Identify the correct statement for the rotational motion of a rigid body

- |   |   |  |  |
|---|---|--|--|
| a) Individual particles of the body do not undergo accelerated motion | b) The centre of mass of the body remains unchanged | c) The centre of mass of the body moves uniformly in a circular path | d) Individual particles and centre of mass of the body undergo an accelerated motion |
|---|---|--|--|

585. Two blocks of masses 10 kg and 4 kg are connected by a spring of negligible mass and placed on frictionless horizontal surface. An impulsive force gives a velocity of  $14\text{ms}^{-1}$  to the heavier block in the direction of the lighter block. The velocity of centre of mass of the system at that very moment is

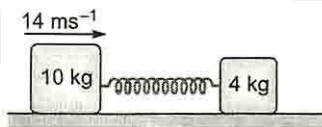

- a)  $30\text{ms}^{-1}$       b)  $20\text{ms}^{-1}$       c)  $10\text{ms}^{-1}$       d)  $5\text{ms}^{-1}$

586. A T shape with dimensions shown in Figure is lying on a smooth floor. A force  $\vec{F}$  is applied at the point P parallel to AB, such that the object has only the translation motion without rotation. Find the location of P with respect to C

Dd

- a)  $l$       b)  $\frac{4}{3}l$       c)  $\frac{3}{2}l$       d)  $\frac{2}{3}l$

587. A meter stick is hold vertically with one end on the floor and is then allowed to fall. Assuming that the end on the floor the stick does not slip, the velocity of the other end when it hits the floor, will be

- a)  $10.8\text{ms}^{-1}$       b)  $5.4\text{ms}^{-1}$       c)  $2.5\text{ms}^{-1}$       d) None of these



588. A spacecraft of mass  $M$  is moving with velocity  $v$  in free space when it explodes and breaks in two. After the explosion, a mass  $m$  of the spacecraft is left stationary. What is the velocity of other part?

- a)  $\frac{Mv}{(M-m)}$       b)  $\frac{mv}{(M+m)}$       c)  $\frac{mv}{(M-m)}$       d)  $\frac{(M+m)v}{M}$

589. A particle moves along a circle of radius  $\frac{20}{\pi}m$  with constant tangential acceleration. If the velocity of the particle is  $80 m/s$  at the end of the second revolution after motion has begin, the tangential acceleration is

- a)  $640 \pi m/s^2$       b)  $160 \pi m/s^2$       c)  $40 \pi m/s^2$       d)  $40 m/s^2$

590. A thin rod of length  $L$  and mass  $M$  is bent at the middle point  $O$  at an angle of  $60^\circ$ . The moment of inertia of the rod about an axis passing through  $O$  and perpendicular to the plane of the rod will be

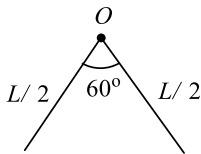

- a)  $\frac{ML^2}{6}$       b)  $\frac{ML^2}{12}$       c)  $\frac{ML^2}{24}$       d)  $\frac{ML^2}{3}$

591. Four point masses, each of value  $m$ , are placed at the corners of a square ABCD of side  $l$ . The moment of inertia of this system about an axis passing through A and parallel to BD is

- a)  $\sqrt{3} ml^2$       b)  $3 ml^2$       c)  $ml^2$       d)  $2 ml^2$

592. There is a uniform circular disc of radius  $R$  and a concentric disc of radius  $r$  (where  $r < R$ ) is cut off from it. The distance of the new position of centre of mass of hollow disc from the centre of disc is

- a)  $\frac{R-r}{2}$       b)  $R-r$       c) Zero      d)  $\sqrt{R^2 - r^2}$

593. A particle of mass  $m$  moves in the  $XY$  plane with a velocity  $v$  along the straight line  $AB$ . If the angular momentum of the particle with respect to origin  $O$  is  $L_A$  when it is at  $A$  and  $L_B$  when it is at  $B$ , then

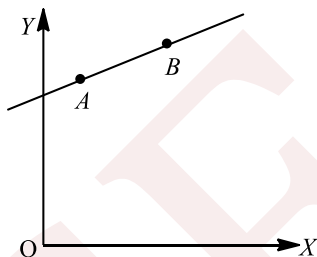

- a)  $L_A > L_B$       b)  $L_A = L_B$       c) The relationship between  $L_A$  and  $L_B$  depends upon the slope of the line  $AB$       d)  $L_A < L_B$

594. A particle of mass  $m = 5 \text{ units}$  is moving with a uniform speed  $v = 3\sqrt{2} \text{ units}$  in the  $XOY$  plane along the straight line  $Y = X + 4$ . The magnitude of the angular momentum about origin is

- a) Zero      b)  $60 \text{ units}$       c)  $75 \text{ units}$       d)  $40\sqrt{2} \text{ units}$

595. If the radius  $r$  of earth suddenly changes to  $x$  times the present values, the new period of rotation would be

- a)  $\frac{dT}{dt} = (T/r)(dr/dt)$       b)  $\frac{dT}{dt} = (2T/r)(dr/dt)$       c)  $\frac{dT}{dt} = (r/T)(dr/dt)$       d)  $\frac{dT}{dt} = \left(\frac{1}{2}T/r\right)(dr/dt)$

596. Four particles of mass  $1 \text{ kg}$ ,  $2 \text{ kg}$ ,  $3 \text{ kg}$  and  $4 \text{ kg}$  are placed at the corners  $A, B, C$  and  $D$  respectively of a square  $ABCD$  of edge  $X$ -axis and edge  $AD$  is taken along  $Y$ -axis, the co-ordinates of centre of mass in SI is



597. a) (1,1)                      b) (5,7)                      c) (0.5,0.7)                      d) None of these  
The moment of inertia of a circular disc of radius 2 m and mass 2 kg, about an axis passing through its centre of mass is  $2 \text{ kg} - \text{m}^2$ . Its moment of inertia about an axis parallel to this axis and passing through its edge (in  $\text{KM} - \text{m}^2$ ) is
598. a) 10                      b) 8                      c) 6                      d) 4  
A constant torque of  $31.4 \text{ N} - \text{m}$  is exerted on a pivoted wheel. If angular acceleration of wheel is  $4\pi \text{ rad/sec}^2$ , then the moment of inertia of the wheel is
599. a)  $2.5 \text{ kg} - \text{m}^2$                       b)  $3.5 \text{ kg} - \text{m}^2$                       c)  $4.5 \text{ kg} - \text{m}^2$                       d)  $5.5 \text{ kg} - \text{m}^2$   
Moment of inertia of a disc about an axis which is tangent and parallel to its plane is  $I$ . Then the moment of inertia of disc about a tangent, but perpendicular to its plane will be
600. a)  $\frac{3I}{4}$                       b)  $\frac{5I}{6}$                       c)  $\frac{3I}{2}$                       d)  $\frac{6I}{5}$   
The moment of inertia of uniform rectangular plate about an axis passing through its centre and parallel to its length  $l$  is ( $b =$  breadth of rectangular plate)
601. a)  $\frac{Mb^2}{4}$                       b)  $\frac{Mb^3}{6}$                       c)  $\frac{Mb^3}{12}$                       d)  $\frac{Mb^2}{12}$   
In an elastic head on collision between two particles
602. a) Velocity of separation is equal to the velocity of approach                      b) Velocity of the target is always more than the velocity of the projectile                      c) The maximum velocity of the target is double to that of the projectile                      d) Maximum transfer of kinetic energy occurs when masses of both projectile and target are equal  
A neutron travelling with velocity  $u$  and kinetic energy  $K$  collides head on elastically with the nucleus of an atom of mass number  $A$  at rest. The fraction of its kinetic energy retained by the neutron even after the collision is
603. a)  $\left(\frac{1-A}{A+1}\right)^2$                       b)  $\left(\frac{A+1}{A-1}\right)^2$                       c)  $\left(\frac{A-1}{A}\right)^2$                       d)  $\left(\frac{A+1}{A}\right)^2$   
The ratio of angular speeds of minute hand and hour hand of a watch is
604. a) 1:12                      b) 6:1                      c) 12:1                      d) 1:6  
A spring pong ball of mass  $m$  is floating in air by a jet of water emerging out of a nozzle. If the water strikes the ping pong ball with a speed  $v$  and just after collision water falls dead, the rate of flow of water in the nozzle is equal to
605. a)  $\frac{2mg}{v}$                       b)  $\frac{m}{g}$                       c)  $\frac{mg}{v}$                       d)  $\frac{2m}{vg}$   
The moment of inertia of a uniform rod about a perpendicular axis passing through one end is  $I_1$ . The same rod is bent into a ring and its moment of inertia about a diameter is  $I_2$ . Then  $\frac{I_1}{I_2}$  is
606. a)  $\frac{\pi^2}{3}$                       b)  $\frac{2\pi^2}{3}$                       c)  $\frac{4\pi^2}{3}$                       d)  $\frac{8\pi^2}{3}$   
An inclined plane makes an angle of  $30^\circ$  with the horizontal. A solid sphere rolling down this inclined plane from rest without slipping has a linear acceleration equal to
607. a)  $\frac{g}{3}$                       b)  $\frac{2g}{3}$                       c)  $\frac{5g}{7}$                       d)  $\frac{5g}{14}$   
A force of  $-F \hat{k}$  acts on  $O$ , the origin of the coordinate system. The torque about the point (1, -1) is



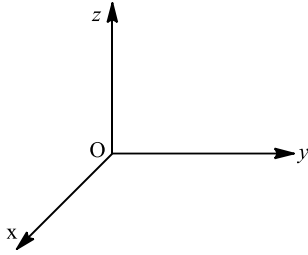

608. Angular momentum of a body is defined as the product of  
 a) Mass and angular velocity    b) Centripetal force and radius    c) Linear velocity and angular velocity    d) Moment of inertia and angular velocity
609. A disc is rolling (without slipping) on a horizontal surface.  $C$  is its centre and  $Q$  and  $P$  are two points equidistant from  $C$ . Let  $v_P$ ,  $v_Q$  and  $v_C$  be the magnitude of velocities of points  $P$ ,  $Q$  and  $C$  respectively, then
- 
- a)  $v_Q > v_C > v_P$     b)  $v_Q < v_C < v_P$     c)  $v_Q = v_P, v_C = \frac{v_P}{2}$     d)  $v_Q < v_C > v_P$
610. A particle with position vector  $r$  has a linear momentum  $p$ . Which of the following statements is true in respect of its angular momentum  $L$  about the origin
- a)  $L$  acts along  $p$     b)  $L$  acts along  $r$     c)  $L$  is maximum when  $p$  and  $r$  are parallel    d)  $L$  is maximum when  $p$  is perpendicular to  $r$
611. The direction of the angular velocity vector is along
- a) The tangent to the circular path    b) The inward radius    c) The outward radius    d) The axis of rotation
612. A solid sphere, a hollow sphere and a ring are released from top of an inclined plane (frictionless) so that they slide down the plane. Then maximum acceleration down the plane is for (no rolling)
- a) Solid sphere    b) Hollow sphere    c) Ring    d) All same
613. A solid sphere rolls down two different inclined planes of same height, but of different inclinations. In both cases,
- a) Speed and time of descent will be same    b) Speed will be same, but time of descent will be different    c) Speed will be different, but time of descent will be same    d) Speed and time of descent both are different
614. The ratio of the radii of gyration of a circular disc about a tangential axis in the plane of the disc and of a circular ring of the same radius about a tangential axis in the plane of the ring is
- a)  $\sqrt{3} : \sqrt{5}$     b)  $\sqrt{12} : \sqrt{3}$     c)  $1 : \sqrt{3}$     d)  $\sqrt{5} : \sqrt{6}$
615. Four holes of radius  $R$  are cut from a thin square plate of side  $4R$  and mass  $M$ . The moment of inertia of the remaining portion about  $z$ -axis is



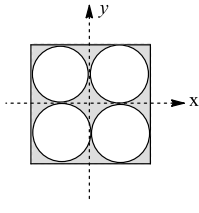

- a)  $\frac{\pi}{12}MR^2$       b)  $\left(\frac{4}{3} - \frac{\pi}{4}\right)MR^2$       c)  $\left(\frac{4}{3} - \frac{\pi}{6}\right)MR^2$       d)  $\left(\frac{8}{3} - \frac{10\pi}{16}\right)MR^2$
616. A machine gun fires 120 shots per minute. If the mass of each bullet is 10 g and the muzzle velocity is  $800 \text{ ms}^{-1}$ , the average recoil force on the machine gun is  
a) 120 N      b) 8 N      c) 16 N      d) 12 N
617. A man of 50 kg mass is standing in a gravity free space at a height of 10m above the floor. He throws a stone of 0.5 kg mass downwards with a speed of 2m/s. When the stone reaches the floor, the distance of the man above the floor will be  
a) 20m      b) 9.9m      c) 10.1m      d) 10m
618. A particle of mass  $m$  is rotating in a plane in circular path of radius  $r$ . Its angular momentum is  $L$ . The central force acting on the particle is  
a)  $L^2/mr$       b)  $L^2m/r$       c)  $L^2/m^2r^2$       d)  $L^2/mr^3$
619. The wheel of a car is rotating at the rate of 1200 revolutions per minute. On pressing the accelerator for 10 seconds. It starts rotating at 4500 revolutions per minute. The angular acceleration of the wheel is  
a) 30 radians/second<sup>2</sup>      b) 1880 degrees/second<sup>2</sup>      c) 40 radians/second<sup>2</sup>      d) 1980 degrees/second<sup>2</sup>
620. For spheres each of mass  $M$  and radius  $R$  are placed with their centers on the four corners  $A, B, C$  and  $D$  of a square of side  $b$ . The spheres  $A$  and  $B$  are hollow and  $C$  and  $D$  are solids. The moment of inertia of the system about side  $AD$  of square is  
a)  $\frac{8}{3}MR^2 + 2Mb^2$       b)  $\frac{8}{5}MR^2 + 2Mb^2$       c)  $\frac{32}{15}MR^2 + 2Mb^2$       d)  $32MR^2 + 4Mb^2$
621. If momentum of a body remains constant, then mass-speed graph of body is  
a) Circle      b) Straight line      c) Rectangular hyperbola      d) Parabola
622. Two circular rings have their masses in the ratio of 1:2 and their diameters in the ratio of 2:1. The ratio of their moment of inertia is  
a) 1 : 4      b) 2 : 1      c) 4 : 1      d)  $\sqrt{2} : 1$
623. A particle is projected with a speed  $v$  at  $45^\circ$  with the horizontal. The magnitude of angular momentum of the projectile about the point of projection when the particle is at its maximum height  $h$  is  
a) Zero      b)  $\frac{mvh^2}{\sqrt{2}}$       c)  $\frac{mv^2h}{\sqrt{2}}$       d)  $\frac{mv^2h}{\sqrt{2}}$
624. Let  $\mathbf{F}$  be the force acting on a particle having position vector  $\mathbf{r}$  and  $\boldsymbol{\tau}$  be the torque of this force about the origin. Then  
a)  $\mathbf{r} \cdot \boldsymbol{\tau} = 0$  and  $\mathbf{F} \cdot \boldsymbol{\tau} \neq 0$       b)  $\mathbf{r} \cdot \boldsymbol{\tau} \neq 0$  and  $\mathbf{F} \cdot \boldsymbol{\tau} = 0$       c)  $\mathbf{r} \cdot \boldsymbol{\tau} \neq 0$  and  $\mathbf{F} \cdot \boldsymbol{\tau} \neq 0$       d)  $\mathbf{r} \cdot \boldsymbol{\tau} = 0$  and  $\mathbf{F} \cdot \boldsymbol{\tau} = 0$
625. If kinetic energy of a body remains constant, then momentum-mass graph is



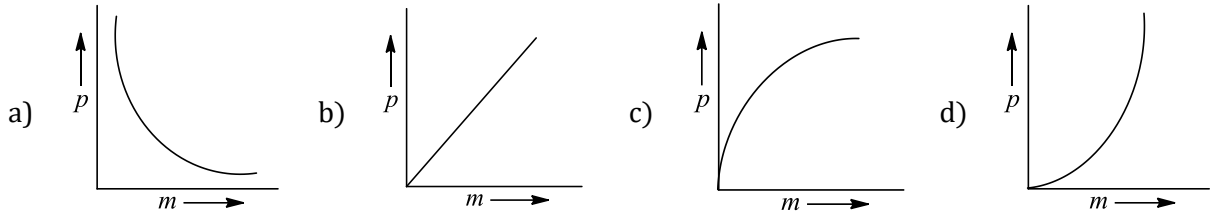

626. Moment of inertia of a disc about a diameter is  $I$ . Find the moment of inertia of disc about an axis perpendicular to its plane and passing through its rim?  
 a)  $6I$                       b)  $4I$                       c)  $2I$                       d)  $8I$
627. The moment of inertia of wheel about the axis of rotation is 3.0 MKS units. Its kinetic energy will be 600 J if period of rotation is  
 a) 0.05 s                      b) 0.314 s                      c) 3.18 s                      d) 20 s
628. A tennis ball bounces down flight of stairs striking each step in turn and rebounding to the height of the step above. The coefficient of restitution has a value  
 a)  $1/2$                       b) 1                      c)  $1/\sqrt{2}$                       d)  $1/2\sqrt{2}$
629. A body is rolling without slipping on a horizontal surface and its rotational kinetic energy is equal to the translational kinetic energy. The body is  
 a) Disc                      b) Sphere                      c) Cylinder                      d) Ring
630. Two rings of radius  $R$  and  $nR$  made up of same material have the ratio of moment of inertia about an axis passing through centre is 1 : 8. The value of  $n$  is  
 a) 2                      b)  $2\sqrt{2}$                       c) 4                      d)  $\frac{1}{2}$
631. A homogeneous disc of mass 2 kg and radius 15 cm is rotating about its axis (which is fixed) with an angular velocity of 4 radian/s. The linear momentum of the disc is  
 a) 1.2 kg-m/s                      b) 1.0 kg-m/s                      c) 0.6 kg-m/s                      d) None of the above
632. The center of mass of three particles of masses 1 kg, 2 kg and 3 kg at (3, 3, 3) with reference to a fixed coordinate system. Where should a fourth particle of mass 4 kg should be placed, so that the center of mass of the system of all particles shifts to a point (1, 1, 1)?  
 a) (-1, -1, -1)                      b) (-2, -2, -2)                      c) (2, 2, 2)                      d) (1, 1, 1)
633. Moment of inertia along the diameter of a ring is  
 a)  $\frac{3}{2}MR^2$                       b)  $\frac{1}{2}MR^2$                       c)  $MR^2$                       d)  $2MR^2$
634. What constant force, tangential to the equator should be applied to the earth to stop its rotation in one day  
 a)  $1.3 \times 10^{22}N$                       b)  $8.26 \times 10^{28} N$                       c)  $1.3 \times 10^{23} N$                       d) None of these
635. When the distance between earth and sun is halved, the duration of year will become  
 a) More                      b) Less                      c) Can't be                      d) None of the above determined
636. A thin circular ring of mass  $m$  and radius  $R$  is rotating about its axis with a constant angular velocity  $\omega$ . Two objects each of mass  $M$  are attached gently to the opposite ends of a diameter of the ring the ring. The ring now rotates with an angular velocity  $\omega'$  is equal to  
 a)  $\frac{\omega(m+2M)}{m}$                       b)  $\frac{\omega(m-2M)}{(m+2M)}$                       c)  $\frac{\omega m}{(m+M)}$                       d)  $\frac{\omega m}{(m+2M)}$
637. Three point masses, each of mass  $m$  are placed at the corners of an equilateral triangle of side  $l$ . Moment of inertia of this system about an axis along one side of triangle is  
 a)  $3ml^2$                       b)  $\frac{3}{2}ml^2$                       c)  $ml^2$                       d)  $\frac{3}{4}ml^2$



638. The two bodies of mass  $m_1$  and  $m_2$  ( $m_1 > m_2$ ) respectively are tied to the ends of a massless string, which passes over a light and frictionless pulley. The masses are initially at rest and the released. Then acceleration of the centre of mass of the system is

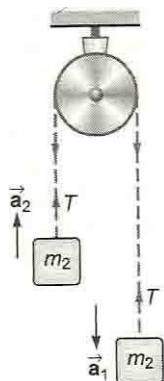

- a)  $\left[ \frac{m_1 - m_2}{m_1 + m_2} \right]^2 g$       b)  $\left[ \frac{m_1 - m_2}{m_1 + m_2} \right]^2$       c)  $g$       d) zero
639. A particle is moving in a circular path. The correct statement out of the following is  
a) Angular momentum will be conserved but linear momentum will not be conserved      b) Angular momentum will not be conserved      c) Linear momentum will be conserved      d) Both will not be conserved
640. A mass  $m$  hangs with the help of a string wrapped around a pulley on a frictionless bearing. The pulley has mass  $m$  and radius  $R$ . Assuming pulley to be a perfect uniform circular disc, the acceleration of the mass  $m$ , if the string does not slip on the pulley, is  
a)  $g$       b)  $\frac{2}{3}g$       c)  $\frac{g}{3}$       d)  $\frac{3}{2}g$
641. Ratio of total kinetic energy and rotational kinetic energy in the motion of a disc is  
a) 1:1      b) 2:7      c) 1:2      d) 3:1
642. What remains constant when the earth revolves around the sun  
a) Angular momentum      b) Linear momentum      c) Angular kinetic energy      d) Linear kinetic energy
643. A system consists of three particles, each of mass  $m$  and located at (1, 1) (2, 2) and (3, 3). The coordinates of the centre of mass are  
a) (1, 1)      b) (2, 2)      c) (3, 3)      d) (6, 6)
644. Choose the correct statement about the centre of mass ( $CM$ ) of a system of two particles  
a) The  $CM$  lies on the line joining the two particles midway between them      b) The  $CM$  lies on the line joining them at a point whose distance from each particle is inversely proportional to the mass of that particle      c) The  $CM$  lies on the line joining them at a point whose distance from each particle is proportional to the square of the mass of that particle      d) The  $CM$  is on the line joining them at a point whose distance from each particle is proportional to the mass of that particle
645. An inclined plane makes an angle of  $30^\circ$  with the horizontal. A solid sphere rolling down the inclined plane from rest without slipping has a linear acceleration equal to  
a)  $5g/14$       b)  $5g/4$       c)  $2g/3$       d)  $g/3$



646. A uniform rod  $AB$  of length  $l$  and mass  $m$  is free to rotate about point  $A$ . The rod is released from rest in the horizontal position. Given that the moment of inertia of the rod about  $A$  is  $\frac{ml^2}{3}$ , the initial angular acceleration of the rod will be

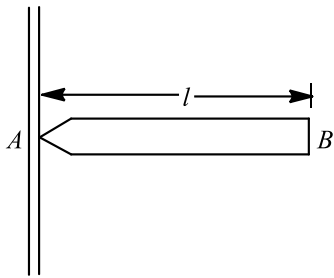

a)  $\frac{2g}{3l}$

b)  $mg \frac{l}{2}$

c)  $\frac{3}{2}gl$

d)  $\frac{3g}{2l}$

SENJEE



## PHYSICS

### 7. SYSTEM OF PARTICLES AND ROTATIONAL MOTION

#### : ANSWER KEY :

1)	a	2)	b	3)	c	4)	a
5)	b	6)	c	7)	d	8)	a
9)	c	10)	a	11)	a	12)	a
13)	c	14)	d	15)	a	16)	a
17)	c	18)	d	19)	c	20)	c
21)	b	22)	b	23)	c	24)	a
25)	d	26)	a	27)	d	28)	b
29)	a	30)	c	31)	b	32)	a
33)	a	34)	a	35)	a	36)	d
37)	a	38)	c	39)	d	40)	c
41)	d	42)	a	43)	b	44)	d
45)	a	46)	c	47)	b	48)	b
49)	b	50)	c	51)	d	52)	c
53)	a	54)	a	55)	b	56)	a
57)	c	58)	b	59)	d	60)	c
61)	b	62)	c	63)	a	64)	b
65)	d	66)	b	67)	a	68)	b
69)	c	70)	a	71)	b	72)	b
73)	b	74)	d	75)	b	76)	b
77)	c	78)	c	79)	c	80)	d
81)	a	82)	d	83)	c	84)	a
85)	c	86)	a	87)	a	88)	a
89)	b	90)	c	91)	a	92)	d
93)	d	94)	b	95)	c	96)	a
97)	c	98)	b	99)	a	100)	b
101)	d	102)	d	103)	a	104)	a
105)	d	106)	b	107)	a	108)	b
109)	b	110)	c	111)	b	112)	c
113)	a	114)	d	115)	c	116)	b
117)	c	118)	d	119)	d	120)	c
121)	d	122)	a	123)	a	124)	b
125)	c	126)	c	127)	d	128)	a
129)	a	130)	b	131)	d	132)	c
133)	d	134)	b	135)	c	136)	d
137)	d	138)	a	139)	d	140)	a
141)	c	142)	c	143)	b	144)	b
145)	a	146)	c	147)	b	148)	d



- 149) c    150) b    151) b    152) c  
153) a    154) b    155) d    156) a  
157) d    158) a    159) b    160) b  
161) c    162) d    163) b    164) d  
165) d    166) b    167) b    168) c  
169) a    170) d    171) b    172) d  
173) a    174) b    175) b    176) d  
177) c    178) c    179) a    180) a  
181) c    182) a    183) d    184) a  
185) b    186) a    187) c    188) b  
189) a    190) a    191) a    192) d  
193) a    194) d    195) c    196) b  
197) a    198) b    199) d    200) c  
201) b    202) d    203) b    204) b  
205) c    206) a    207) c    208) d  
209) a    210) c    211) d    212) a  
213) b    214) d    215) a    216) a  
217) d    218) c    219) d    220) d  
221) c    222) d    223) b    224) d  
225) b    226) b    227) a    228) c  
229) b    230) a    231) c    232) c  
233) a    234) c    235) b    236) b  
237) a    238) b    239) c    240) c  
241) b    242) d    243) b    244) a  
245) b    246) a    247) b    248) d  
249) b    250) a    251) b    252) a  
253) d    254) a    255) d    256) d  
257) c    258) a    259) b    260) a  
261) d    262) c    263) a    264) b  
265) b    266) b    267) b    268) c  
269) c    270) d    271) a    272) a  
273) d    274) d    275) b    276) b  
277) a    278) c    279) a    280) b  
281) d    282) c    283) c    284) a  
285) a    286) c    287) d    288) b  
289) c    290) a    291) b    292) c  
293) c    294) a    295) a    296) c  
297) c    298) a    299) c    300) d  
301) d    302) c    303) a    304) a  
305) b    306) d    307) a    308) d  
309) a    310) a    311) b    312) b  
313) b    314) d    315) c    316) d  
317) d    318) c    319) c    320) b  
321) b    322) d    323) c    324) a  
325) a    326) b    327) d    328) a  
329) c    330) d    331) a    332) c



- |        |        |        |        |
|--------|--------|--------|--------|
| 333) c | 334) d | 335) a | 336) c |
| 337) c | 338) d | 339) b | 340) c |
| 341) a | 342) d | 343) b | 344) a |
| 345) b | 346) a | 347) d | 348) c |
| 349) d | 350) d | 351) c | 352) a |
| 353) a | 354) c | 355) a | 356) d |
| 357) a | 358) a | 359) b | 360) b |
| 361) d | 362) a | 363) d | 364) d |
| 365) b | 366) a | 367) a | 368) b |
| 369) b | 370) a | 371) c | 372) d |
| 373) d | 374) b | 375) a | 376) b |
| 377) c | 378) c | 379) a | 380) d |
| 381) c | 382) c | 383) c | 384) c |
| 385) d | 386) b | 387) d | 388) d |
| 389) c | 390) b | 391) d | 392) a |
| 393) c | 394) b | 395) a | 396) d |
| 397) c | 398) b | 399) a | 400) a |
| 401) b | 402) b | 403) b | 404) b |
| 405) d | 406) c | 407) a | 408) c |
| 409) a | 410) c | 411) b | 412) c |
| 413) c | 414) a | 415) c | 416) a |
| 417) a | 418) b | 419) b | 420) b |
| 421) a | 422) a | 423) b | 424) b |
| 425) b | 426) a | 427) c | 428) a |
| 429) c | 430) c | 431) b | 432) a |
| 433) a | 434) a | 435) a | 436) d |
| 437) d | 438) c | 439) b | 440) a |
| 441) d | 442) c | 443) a | 444) b |
| 445) c | 446) c | 447) d | 448) d |
| 449) a | 450) d | 451) c | 452) d |
| 453) d | 454) b | 455) b | 456) d |
| 457) c | 458) b | 459) b | 460) c |
| 461) a | 462) a | 463) d | 464) a |
| 465) d | 466) a | 467) a | 468) a |
| 469) b | 470) a | 471) b | 472) b |
| 473) d | 474) d | 475) c | 476) d |
| 477) c | 478) c | 479) a | 480) d |
| 481) b | 482) b | 483) b | 484) b |
| 485) d | 486) c | 487) b | 488) b |
| 489) a | 490) c | 491) c | 492) a |
| 493) a | 494) c | 495) d | 496) b |
| 497) c | 498) b | 499) a | 500) c |
| 501) b | 502) b | 503) c | 504) d |
| 505) b | 506) a | 507) c | 508) a |
| 509) a | 510) a | 511) d | 512) d |
| 513) b | 514) c | 515) b | 516) a |



517)	b	518)	b	519)	c	520)	c
521)	d	522)	d	523)	d	524)	a
525)	c	526)	a	527)	c	528)	a
529)	b	530)	d	531)	b	532)	a
533)	b	534)	b	535)	b	536)	d
537)	b	538)	a	539)	d	540)	a
541)	b	542)	b	543)	b	544)	b
545)	b	546)	d	547)	b	548)	c
549)	d	550)	d	551)	b	552)	b
553)	c	554)	a	555)	d	556)	a
557)	b	558)	b	559)	c	560)	d
561)	b	562)	b	563)	d	564)	c
565)	b	566)	b	567)	b	568)	c
569)	b	570)	a	571)	c	572)	d
573)	d	574)	d	575)	d	576)	c
577)	c	578)	b	579)	c	580)	d
581)	a	582)	c	583)	b	584)	b
585)	c	586)	b	587)	b	588)	a
589)	d	590)	b	591)	b	592)	c
593)	b	594)	b	595)	b	596)	c
597)	a	598)	a	599)	d	600)	d
601)	a	602)	a	603)	c	604)	c
605)	d	606)	d	607)	c	608)	d
609)	a	610)	d	611)	d	612)	d
613)	b	614)	d	615)	d	616)	c
617)	c	618)	d	619)	d	620)	c
621)	c	622)	b	623)	d	624)	d
625)	c	626)	a	627)	b	628)	c
629)	d	630)	a	631)	d	632)	b
633)	b	634)	a	635)	b	636)	d
637)	d	638)	a	639)	a	640)	b
641)	d	642)	a	643)	b	644)	b
645)	a	646)	d				



## PHYSICS

### 7. SYSTEM OF PARTICLES AND ROTATIONAL MOTION

#### : HINTS AND SOLUTIONS :

##### Single Correct Answer Type

1 **(a)**  
As in Q.6  $\rightarrow v_1 = \frac{v}{2}(1 - e)$   
Similarly it is found that  $v_2 = \frac{v}{2}(1 + e)$   
Hence,  $\frac{v_1}{v_2} = \frac{(1-e)}{(1+e)}$

2 **(b)**  
If the surface is smooth, then relative acceleration between blocks is zero. So, no compression or elongation takes place in spring. Hence, spring force on blocks is zero.

4 **(a)**  
 $c = \frac{dL}{dt} = \frac{L_2 - L_1}{\Delta t} = \frac{4A_0 - A_0}{4} = \frac{3A_0}{4}$

5 **(b)**  
Rotational kinetic energy of flywheel  
 $K = 360 \text{ J}$   
Angular speed of flywheel ( $\omega$ ) = 20  $\text{rads}^{-1}$   
Rotational kinetic energy,  $K = \frac{1}{2}I\omega^2$   
 $\therefore$  Moment of inertia,  $I = \frac{2K}{\omega^2}$   
 $= \frac{2 \times 360}{(20)^2} = 1.8 \text{ kg} - \text{m}^2$

6 **(c)**  
Kinetic energy  $K = \frac{J^2}{2I}$   
where  $J$  is angular momentum and  $I$  the moment of inertia.  
 $\therefore K_1 = \frac{J^2}{2I}, K_2 = \frac{(J + \frac{10}{100}J)^2}{2I}$   
 $\therefore \frac{K_1}{K_2} = \frac{(100)^2}{(110)^2} = \frac{100}{121}$   
 $\% \text{ change} = \frac{K_2 - K_1}{K_1} = \frac{K_2}{K_1} - 1$   
 $= \frac{121}{100} - 1 = 21\%$

7 **(d)**  
As  $m_1 = m_2 \therefore \pi R_1^2 x d_1 = \pi R_2^2 x d_2$   
 $\frac{R_1^2}{R_2^2} = \frac{d_2}{d_1}$   
Now,  $\frac{l_1}{l_2} = \frac{\frac{1}{2}mR_1^2}{\frac{1}{2}mR_2^2} = \frac{R_1^2}{R_2^2} = \frac{d_2}{d_1}$



8 **(a)**  
MI of disc about tangent in a plane

$$= \frac{5}{4}MR^2 = I$$

$$\therefore mR^2 = \frac{4}{5}I$$

MI of disc about tangent  $I$  to plane  $I' = \frac{3}{2}mR^2$

$$\therefore I' = \frac{3}{2} \left( \frac{4}{5}I \right)$$

$$= \frac{6}{5}I$$

9 **(c)**

Given,  $m_1 = 6 \text{ kg}$ ,  $m_2 = 4 \text{ kg}$

$$\mathbf{v}_1 = 5\hat{i} - 2\hat{j} + 10\hat{k}, \quad \mathbf{v}_2 = 10\hat{i} - 2\hat{j} + 5\hat{k}$$

The velocity of centre of mass is

$$\begin{aligned} \mathbf{v} &= \frac{m_1\mathbf{v}_1 + m_2\mathbf{v}_2}{m_1 + m_2} \\ &= \frac{6(5\hat{i} - 2\hat{j} + 10\hat{k}) + 4(10\hat{i} - 2\hat{j} + 5\hat{k})}{6 + 4} \\ &= \frac{70\hat{i} - 20\hat{j} + 80\hat{k}}{10} = 7\hat{i} - 2\hat{j} + 8\hat{k} \end{aligned}$$

10 **(a)**

$$\mathbf{v}_{\text{CM}} = \frac{m_1\mathbf{v}_1 + m_2\mathbf{v}_2}{m_1 + m_2} = \frac{\mathbf{v}_1 + \mathbf{v}_2}{2} \quad (\text{as } m_1 = m_2)$$

$$\begin{aligned} \text{and } \mathbf{a}_{\text{CM}} &= \frac{m_1\mathbf{a}_1 + m_2\mathbf{a}_2}{m_1 + m_2} \\ &= \frac{\mathbf{a}_1 + 0}{2} = \frac{\mathbf{a}_1}{2} \end{aligned}$$

The centre of mass of two particles will move with the mean velocity of two particles having common acceleration  $\frac{\mathbf{a}}{2}$ .

Hence, path of CM will be a straight line.

11 **(a)**

Angular velocity is related to the rotating body

12 **(a)**

Retardation due to friction

$$\begin{aligned} a &= \mu g = (0.25)(10) \\ &= 2.5 \text{ ms}^{-2} \end{aligned}$$

Collision is elastic, i.e. after collision first block comes to rest and the second block acquires the velocity of first block. Or we can understand it in this manner that second block is permanently at rest while only the first block moves. Distance travelled by it will be

$$s = \frac{v^2}{2a} = \frac{(5)^2}{(2)(2.5)} = 5 \text{ m}$$

$\therefore$  Final separation will be  $(s - 2) = 3 \text{ m}$

13 **(c)**

Rotational kinetic energy  $E = \frac{L^2}{2I} \therefore L = \sqrt{2EI}$

$$\Rightarrow \frac{L_A}{L_B} = \sqrt{\frac{E_A}{E_B} \times \frac{I_A}{I_B}} = \sqrt{100 \times \frac{1}{4}} = 5$$

14 **(d)**



Due to presence of contact (frictional) force momenta of blocks  $A$  and  $B$  separately change but total sum of momenta of  $A$  and  $B$  taken together is constant because no net external force is acting on the system.

15 (a)

Total KE at bottom;

$$\begin{aligned} &= \frac{1}{2}mv^2 \left[1 + \frac{K^2}{R^2}\right] \\ &= \frac{1}{2}mv^2 \left[1 + \frac{2}{5}\right] = \frac{7}{10}mv^2 \end{aligned}$$

16 (a)

Moment of inertia of the solid sphere of mass  $M$  and radius  $R$  about is tangent

$$I = I_0 + MR^2$$

(According to theorem of parallel axis)

$$= \frac{2}{5}MR^2 + MR^2 \quad (\because I_0 = \frac{2}{5}MR^2)$$

$$I = \frac{7}{5}MR^2$$

17 (c)

$\vec{\tau} = \frac{d\vec{L}}{dt}$ , if  $\tau = 0$  then  $\vec{L} = \text{constant}$  i. e.  $L$  remains constant in magnitude and as well as in direction

18 (d)

Applying theorem of parallel axes

$$I = I_0 + M(R/2)^2 = \frac{1}{2}MR^2 + \frac{MR^2}{4} = \frac{3}{4}MR^2$$

19 (c)

$$t = \frac{1}{\sin \theta} \sqrt{\frac{2h}{g} \left(1 + \frac{K^2}{R^2}\right)}$$

$$\Rightarrow \frac{t_S}{t_D} = \sqrt{\frac{1 + \left(\frac{K^2}{R^2}\right)_S}{1 + \left(\frac{K^2}{R^2}\right)_D}}$$

$$= \sqrt{\frac{1 + \frac{2}{5}}{1 + \frac{1}{2}}} = \sqrt{\frac{14}{15}}$$

20 (c)

As there is no external force, hence

$$\vec{p} = \vec{p}_1 + \vec{p}_2 + \vec{p}_3 = \text{constant}$$

$$\Rightarrow |\vec{p}_3| = |\vec{p}_1 + \vec{p}_2| = \frac{m}{4} \sqrt{(3)^2 + (4)^2} = \frac{5m}{4}$$

[since  $v_1$  and  $v_2$  are mutually perpendicular]

$$\therefore p_3 = \frac{m}{2}v_3 = \frac{5m}{4}$$

$$\Rightarrow v_3 = \frac{5}{2} = 2.5\text{ms}^{-1}$$

21 (b)

Moment of inertia of circular ring about an axis passing through its centre of mass and perpendicular to its plane

$$I = MR^2$$

Here,  $I = 4 \text{ kg} - \text{m}^2, m = 1 \text{ kg}$



$$R^2 = \frac{4}{1} = 4$$

or  $R = 2\text{m}$

Therefore, diameter of ring = 4 m.

23 **(c)**

In the field central force, Torque = 0  $\therefore$  angular momentum remains constant

24 **(a)**

Angular momentum,  $L = mr^2\omega = \text{constant}$

$$\frac{\omega_2}{\omega_1} = \left(\frac{r_1}{r_2}\right)^2 = \left(\frac{0.8}{1}\right)^2 = 0.64 \Rightarrow \omega_2 = 44 \times 0.64 = 28.16 \frac{\text{rad}}{\text{s}}$$

25 **(d)**

Time taken by first block to reach second block =  $\frac{L}{v}$

Since collision is 100% elastic, now first block comes to rest and 2nd block starts moving towards the 3rd block with a velocity  $v$  and takes time =  $\frac{L}{v}$  to reach 3rd block and so on

$$\therefore \text{Total time} = t + t + \dots (n-1) \text{ time} = (n-1) \frac{L}{v}$$

Finally only the last  $n$ th block is in motion velocity  $v$ , hence final velocity of centre of mass

$$v_{\text{CM}} = \frac{mv}{nm} = \frac{v}{n}$$

26 **(a)**

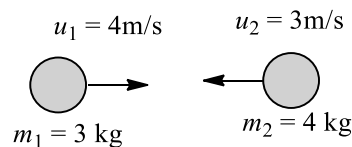

$$m_1 u_1 + m_2 u_2 = (m_1 + m_2) v$$

$$3 \times 4 + 4 \times (-3) = (3 + 4) v \quad v = 0$$

27 **(d)**

Apply parallel axis theorem

$$I = I_{\text{CM}} + Mh^2$$

$$= \frac{ML^2}{12} + M \left(\frac{L}{4}\right)^2$$

$$= \frac{7ML^2}{48}$$

28 **(b)**

Angular momentum about origin

$$|\mathbf{L}| = |\mathbf{r} \times m\mathbf{v}|$$

$$= (4 \cos 45^\circ) \times (5) \times 3\sqrt{2}$$

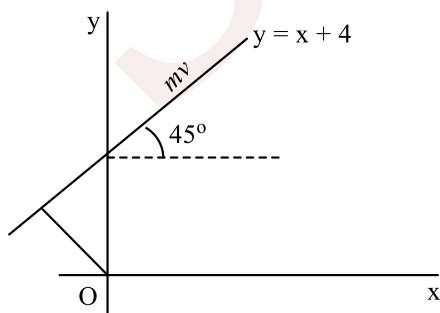

$$= \frac{a}{\sqrt{2}} \times 5 \times 3\sqrt{2}$$



$$|\mathbf{L}| = 60 \text{ unit}$$

29 (a)

$$\alpha = \frac{\tau}{I} = \frac{30}{2} = 15 \text{ rad/s}^2$$

$$\therefore \theta = \omega_0 t + \frac{1}{2} \alpha t^2 = 0 + \frac{1}{2} \times (15) \times (10)^2 = 750 \text{ rad}$$

30 (c)

The moment of inertia about an axis passing through centre of mass of disc and perpendicular to its plane is

$$I_{CM} = \frac{1}{2} MR^2$$

where  $M$  is the mass of disc and  $R$  its radius. According to theorem of parallel axis, moment of inertia of circular disc about an axis touching the disc about an axis touching the disc at its diameter and normal to the disc is

$$\begin{aligned} I &= I_{CM} + MR^2 \\ &= \frac{1}{2} MR^2 + MR^2 \\ &= \frac{3}{2} MR^2 \end{aligned}$$

31 (b)

$$\begin{aligned} I &= m_1 r_1^2 + m_2 r_2^2 \\ &= \frac{200}{1000} \left( \frac{30}{100} \right)^2 + \frac{300}{1000} \left( \frac{20}{100} \right)^2 = 0.03 \text{ kg m}^2 \end{aligned}$$

33 (a)

By conservation of angular momentum

$$I_t \omega_i = (I_t + I_b) \omega_f \Rightarrow \omega_f = \left( \frac{I_t}{I_t + I_b} \right) \omega_i$$

$$\text{Loss in kinetic energy} = \frac{1}{2} I_t \omega_i^2 - \frac{1}{2} (I_t + I_b) (\omega_f^2)$$

$$= \frac{1}{2} \left( \frac{I_b I_t}{I_b + I_t} \right) \omega_i^2$$

34 (a)

For centre of mass,

$$x_{cm} = \frac{2 \times 1 + 4 \times 1 + 4 \times 0}{2 + 4 + 4} = \frac{6}{10} = \frac{3}{5}$$

$$y_{cm} = \frac{2 \times 0 + 4 \times 1 + 4 \times 1}{2 + 4 + 4} = \frac{8}{10} = \frac{4}{5}$$

$$\therefore \text{Coordinate for } cm = \left( \frac{3}{5} \hat{i}, \frac{4}{5} \hat{j} \right)$$

Where  $\hat{i}$  and  $\hat{j}$  are unit vector along  $x$  and  $y$  axis

35 (a)

Here a thin wire of length  $L$  is bent to form a circular ring.

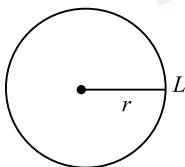

Then,  $2\pi r = L$  ( $r$  is the radius of ring)

$$\Rightarrow r = \frac{L}{2\pi}$$

Hence, the moment of inertia of the ring about its axis



$$I = Mr^2 \Rightarrow I = M \left( \frac{L}{2\pi} \right)^2 \Rightarrow I = \frac{ML^2}{4\pi^2}$$

36 **(d)**

Since net force acting on the system is zero, hence position of centre of mass of the system remains unchanged *ie*, velocity of the centre of mass is zero

37 **(a)**

$$\text{Rotational kinetic energy } K_R = \frac{1}{2} I \omega^2$$

$$\begin{aligned} \therefore \text{Its moment of inertia} &= \frac{2K_R}{\omega^2} \\ &= 2 \times \frac{360}{(30)^2} \\ &= 0.8 \text{ kg} - \text{m}^2 \end{aligned}$$

38 **(c)**

The angular momentum of a disc of moment of inertia  $I_1$  and rotating about its axis with angular velocity  $\omega$  is

$$L_1 = I_1 \omega$$

When a round disc of moment of inertia  $I_2$  is placed on first disc, then angular momentum of the combination is

$$L_2 = (I_1 + I_2) \omega'$$

In the absence of any external torque, angular momentum remains conserved, *ie.*,

$$\begin{aligned} L_1 &= L_2 \\ I_1 \omega &= (I_1 + I_2) \omega' \\ \Rightarrow \omega' &= \frac{I_1 \omega}{I_1 + I_2} \end{aligned}$$

39 **(d)**

On applying law of conservation of angular momentum

$$I_1 \omega_1 = I_2 \omega_2$$

For solid sphere,

$$I = \frac{2}{5} mr^2 \Rightarrow \frac{2}{5} mr_1^2 \omega_1 = \frac{2}{5} mr_2^2 \omega_2$$

$$r^2 \omega = \left( \frac{r}{n} \right)^2 \omega_2 \Rightarrow \omega_2 = n^2 \omega$$

40 **(c)**

As is clear from the equation,

$$|(m_1 \vec{v}_1 + m_2 \vec{v}_2) - (m_1 \vec{v}_1 + m_2 \vec{v}_2)|$$

= change in linear momentum of the two particles

= external force on the system  $\times$  time interval

$$= [(m_1 + m_2)g] \times (2t_0) = 2(m_1 + m_2)gt_0$$

41 **(d)**

$$\pi r = l \therefore r = l/\pi$$

$$\text{Moment of inertia of a ring about its diameter} = \frac{1}{2} Mr^2$$

$$\therefore \text{Moment of inertia of semicircle} = \frac{1}{2} \left[ m \left( \frac{l}{\pi} \right)^2 \right] = \frac{ml^2}{2\pi^2}$$

42 **(a)**

Assuming that no energy is used up against friction, the loss in potential energy is equal to the total gain in the kinetic energy.



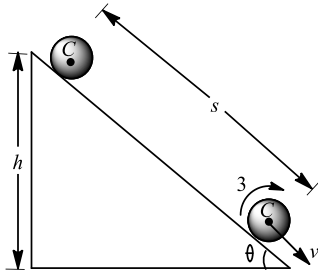

Thus,  $Mgh = \frac{1}{2}I(v^2/R^2) + \frac{1}{2}Mv^2$

or  $\frac{1}{2}v^2(M + I/R^2) = Mgh$

or  $v^2 = \frac{2Mgh}{M + I/R^2} = \frac{2gh}{1 + I/MR^2}$

If  $s$  be the distance covered along the plane,

$$h = s \sin \theta$$

$$v^2 = \frac{2gs \sin \theta}{1 + I/MR^2}$$

Now,  $v^2 = 2as$

$\therefore 2as = \frac{2gs \sin \theta}{1 + I/MR^2}$  or  $a = \frac{g \sin \theta}{1 + I/MR^2}$

44

**(d)**

At the highest point momentum of particle before explosion  $\vec{p} = mv \cos 60^\circ$

$$= m \times 200 \frac{1}{2} = 100m \text{ horizontally}$$

Now as there is no external force during explosion, hence

$$\vec{p} = \vec{p}_1 + \vec{p}_2 + \vec{p}_3$$

However, since velocities of two fragments, of masses  $m/3$  each, are  $100 \text{ ms}^{-1}$  downward and  $100 \text{ ms}^{-1}$  upward.

hence,  $\vec{p}_1 = -\vec{p}_2$  or  $\vec{p}_1 + \vec{p}_2 = 0$

$$\vec{p}_3 = \frac{m}{3} \cdot v_3 = \vec{p} = 100 \text{ m horizontally}$$

$$v_3 = 300 \text{ ms}^{-1} \text{ horizontally}$$

45

**(a)**

Taking the moment of forces about centre of gravity  $G$

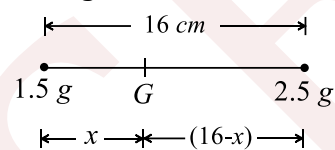

$$(1.5)gx = 2.5g(16 - x) \Rightarrow 3x = 80 - 5x$$

$$\Rightarrow 8x = 80 \Rightarrow x = 10 \text{ cm}$$

46

**(c)**

The car is stopped by the contact force exerted due to road

47

**(b)**

Angular momentum of a rigid body about a fixed axis is given by

$$L = I\omega$$

Where  $I$  is moment of inertia and  $\omega$  is angular velocity about that axis.

Kinetic energy of body is given by

$$K = \frac{1}{2} I\omega^2$$

$$\therefore K = \frac{1}{2I} (L\omega)^2 = \frac{L^2}{2I}$$



$$\Rightarrow I = \frac{L^2}{2K}$$

48 **(b)**

Since, the acceleration of centre of mass in both the cases is same equal to  $g$ . So, the centre of mass of the bodies  $B$  and  $C$  taken together does not shift compared to that of body  $A$ .

49 **(b)**

In this process  $I$  decreases and  $\omega$  increases

50 **(c)**

Here,  $M = 20\text{kg}$ ,  $R = 20\text{cm} = \frac{1}{5}\text{m}$

Moment of inertia of flywheel about its axis is

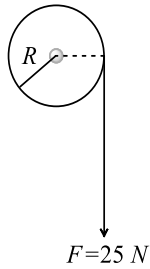

$$I = \frac{1}{2}MR^2 = \frac{1}{2} \times 20\text{kg} \times \left(\frac{1}{5}\text{m}\right)^2 = 0.4\text{kgm}^2$$

As  $\tau = I\alpha$

Where  $\alpha$  is the angular acceleration

$$\therefore \alpha = \frac{\tau}{I} = \frac{FR}{I} = \frac{25 \times \frac{1}{5}}{0.4} = \frac{5\text{Nm}}{0.4\text{kgm}^2} = 12.5\text{s}^{-2}$$

51 **(d)**

As the block remains stationary therefore

For translatory equilibrium

$$\sum F_x = 0 \therefore F = N$$

$$\text{and } \sum F_y = 0 \therefore f = mg$$

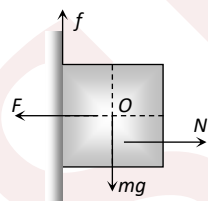

For rotational equilibrium  $\sum \tau = 0$

By taking the torque of different forces about point  $O$

$$\vec{\tau}_F + \vec{\tau}_f + \vec{\tau}_N + \vec{\tau}_{mg} = 0$$

As  $F$  and  $mg$  passing through point  $O$

$$\therefore \vec{\tau}_F + \vec{\tau}_{mg} = 0$$

As  $\vec{\tau}_f \neq 0 \therefore \vec{\tau}_N \neq 0$  and torque by friction and normal reaction will be in opposite direction

52 **(c)**

Linear acceleration for rolling  $a = \frac{g \sin \theta}{(1+K^2/R^2)}$

$$\text{For cylinder } \frac{K^2}{R^2} = \frac{1}{2}$$

$$\therefore a_{\text{cylinder}} = \frac{2}{3}g \sin \theta \quad \dots(i)$$



For rotation, the torque  $fR = I\alpha = (MR^2\alpha)/2$   
(where  $f$  = force of friction)

But  $R\alpha = a \therefore f = \frac{M}{2}a$

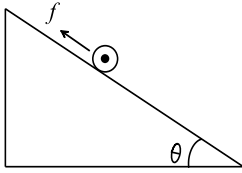

$$\therefore f = \frac{M}{2} \cdot \frac{2}{3}g \sin \theta = \frac{M}{3}g \sin \theta$$

$\mu_s = f/N$  where  $N$  is normal reaction,  $Mg \cos \theta$

$$\mu_s = \frac{\frac{M}{3}g \sin \theta}{Mg \cos \theta} = \frac{\tan \theta}{3}$$

$\therefore$  For rolling without slipping of a roller down the inclined plane,  $\tan \theta \geq 3\mu_s$

53

(a)

$$\omega_1 = 10 \text{ Rad/s}, \omega_2 = 0, t = 10s$$

$$\therefore \alpha = \frac{\omega_2 - \omega_1}{\tau} = \frac{0 - 10}{10} = -1 \text{ rad/s}^2$$

Negative sign means retardation

$$\text{Now } I = mr^2 = 10 \times (0.3)^2 = 0.9 \text{ kg-m}^2$$

$$\therefore \text{Torque } \tau = I\alpha = 0.9 \times (-1) = -0.9 \text{ N-m}$$

54

(a)

Since net momentum of the composite system is zero, hence resultant velocity of the composite system should also be zero.

55

(b)

The mass of considered element is

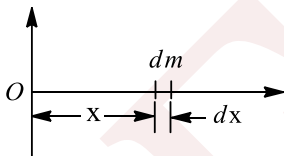

$$dm = \lambda dx = \lambda_0 x dx$$

$$\therefore x_{CM} = \frac{\int_0^L x dm}{\int dm} = \frac{\int_0^L x(\lambda_0 x dx)}{\int_0^L \lambda_0 x dx}$$

$$= \frac{\lambda \left[ \frac{x^3}{3} \right]_0^L}{\lambda_0 \left[ \frac{x^2}{2} \right]_0^L} = \frac{\lambda_0 \frac{L^3}{3}}{\lambda_0 \frac{L^2}{2}} = \frac{2}{3}L$$

56

(a)

Here, effective gravitational acceleration is

$$g' = \frac{mg - qE}{m}$$

$$\therefore R = \frac{v_0^2 \sin 2\alpha}{g'}$$

It means,  $g'$  for both particles are same

This is possible when

$$m_1 = m_2 \text{ and } e_1 = e_2$$

57

(c)



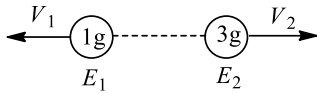

As the momentum of both fragments are equal therefore

$$\frac{E_1}{E_2} = \frac{m_2}{m_1} = \frac{3}{1}$$

$$E_1 = 3E_2$$

According to problem

$$E_1 + E_2 = 6.4 \times 10^4 \text{ J}$$

By solving equation (i) and (ii) we get

$$E_1 = 4.8 \times 10^4 \text{ J and}$$

$$E_2 = 1.6 \times 10^4 \text{ J}$$

58

**(b)**

From the theorem of parallel axis, the moment of inertia  $I$  is equal to

$$I = I_{CM} + Ma^2$$

where  $I_{CM}$  moment of inertia is about centre of mass and  $a$  the distance of axis from centre.

$$\therefore I = MK^2 + M \times (6)^2$$

$$MK_1^2 = MK^2 + 36M$$

$$\Rightarrow K_1^2 = K^2 + 36$$

$$\Rightarrow (10)^2 = K^2 + 36$$

$$\Rightarrow K^2 = 100 - 36 = 64$$

$$\Rightarrow K = 8 \text{ cm}$$

59

**(d)**

When one string is cut off, the rod will rotate about the other point  $A$ . Let  $a$  be the linear acceleration of centre of mass of the rod and  $\alpha$  be the linear acceleration of centre of mass of the rod and  $\alpha$  be the angular acceleration of the rod about  $A$ . As is clear from figure,

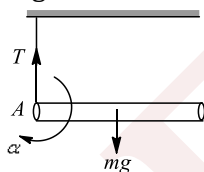

$$mg - T = ma \quad \dots(i)$$

$$\alpha = \frac{\tau}{I} = \frac{mg(l/2)}{ml^2/3} = \frac{3g}{4l} \quad \dots(ii)$$

$$a = r\alpha = \frac{l}{2}\alpha = \frac{l}{2} \cdot \frac{3g}{4l} = \frac{3g}{8}$$

$$\text{From Eq. (i), } T = mg - ma = mg - \frac{3mg}{8} = \frac{5mg}{8}$$

60

**(c)**

Distribution of mass about  $BC$  axis is more than that about  $AB$  axis, *i. e.* radius of gyration about  $BC$  axis is more than that about  $AB$  axis

$$i. e. K_{BC} > K_{AB} \therefore I_{BC} > I_{AB} > I_{CA}$$

61

**(b)**

The speed acquired by block, on account of collision of bullet with it, be  $v_0 \text{ ms}^{-1}$ . Since the block rise by 0.1 m, hence

$$0.1 = \frac{v_0^2}{2g}$$

$$\Rightarrow v_0^2 = 2 \times g \times 0.1 \text{ or } v_0 = \sqrt{2} \text{ ms}^{-1}$$

Now as per conservation of momentum law for collision between bullet and block,



$$\begin{aligned}
 mu &= mu + Mv_0 \\
 \Rightarrow v &= u - \frac{M}{m}v_0 = 500 - \frac{2\text{kg}}{0.01\text{kg}} \times \sqrt{2} \text{ms}^{-1} \\
 &= (500 - 200\sqrt{2})\text{ms}^{-1} \\
 &= 220\text{ms}^{-1}
 \end{aligned}$$

62

(c)

M.I. of body about centre of mass =  $I_{cm} = mK^2$

M.I. of a body about new parallel axis

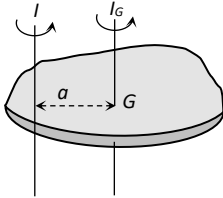

$$I_{new} = I_{cm} + ma^2 = mK^2 + ma^2$$

$$I_{new} = m(K^2 + a^2)$$

$$K_R = \frac{1}{2}I_{new}\omega^2 = \frac{1}{2}m(K^2 + a^2)\omega^2$$

63

(a)

Moment of inertia of the whole system about the axis of rotation will be equal to the sum of the moments of inertia of all the particles.

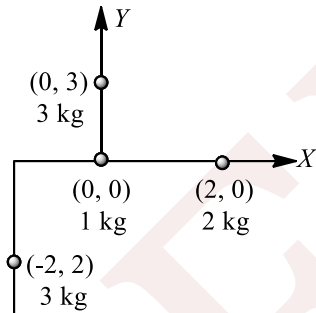

$$I = I_1 + I_2 + I_3 + I_4$$

$$\therefore I = m_1r_1^2 + m_2r_2^2 + m_3r_3^2 + m_4r_4^2$$

$$I = (1 \times 0) + (2 \times 0) + (3 \times 3^2) + 4(-2)^2$$

$$I = 0 + 0 + 27 + 16 = 43 \text{ kg} - \text{m}^2$$

64

(b)

Angular momentum = (Linear momentum)  $\times$  (perpendicular distance to line of motion from the axis)

or angular momentum is moment of momentum. Here, the angle goes on decreasing from  $90^\circ$  but the perpendicular distance to the line of motion remains constant. Therefore, angular momentum is also constant (linear momentum  $p = mv$  is constant).

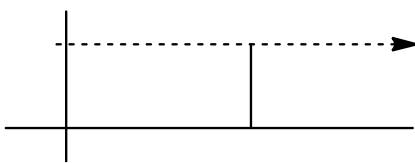

65

(d)



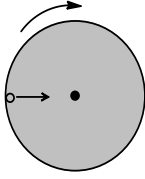

From angular momentum conservation about vertical axis passing through centre. When insect is coming from circumference to centre. Moment of inertia first decrease then increase. So angular velocity increase then decrease

66 (b)

$$\text{We know } v = \sqrt{\frac{2gh}{1 + \frac{k^2}{r^2}}} \therefore \omega = \frac{v}{r} = \sqrt{\frac{2gh}{r^2 + k^2}}$$

$$\Rightarrow \omega = \sqrt{\frac{2mgh}{mr^2 + mk^2}} = \sqrt{\frac{2mgh}{mr^2 + I}} = \sqrt{\frac{2mgh}{I + mr^2}}$$

68 (b)

Angular velocity is given by

$$\begin{aligned} \omega &= 600 \text{ rotation/min} \\ &= \frac{600 \times 2\pi}{60} \text{ rads}^{-1} = 20\pi \text{ rads}^{-1} \end{aligned}$$

Kinetic energy of coin which is due to rotation and translation is

$$\begin{aligned} K &= \frac{1}{2} I\omega^2 + \frac{1}{2} mv^2 \\ &= \frac{1}{2} \times \frac{1}{2} mr^2 \omega^2 + \frac{1}{2} m(\omega r)^2 \\ &= \frac{1}{4} \times 4.8 \times (1)^2 (20\pi)^2 + \frac{1}{2} \times 4.8 \times (20\pi \times 1)^2 \\ &= 480\pi^2 + 960\pi^2 = 1440\pi^2 \text{ J} \end{aligned}$$

69 (c)

$$\omega = 2\pi n = \frac{2\pi \times 1800}{60} = 60\pi \text{ rad/s}$$

$$P = \tau \times \omega \Rightarrow \tau = \frac{P}{\omega} = \frac{100 \times 10^3}{60\pi} = 531 \text{ N-m}$$

70 (a)

$$\text{Time of descent } t = \frac{1}{\sin \theta} \sqrt{\frac{2h}{g} \left( 1 + \frac{K^2}{R^2} \right)}$$

$$\text{For solid sphere } \frac{K^2}{R^2} = \frac{2}{5}$$

$$\text{For hollow sphere } \frac{K^2}{R^2} = \frac{2}{3}$$

$$\text{As } \left( \frac{K^2}{R^2} \right)_{\text{Hollow}} > \left( \frac{K^2}{R^2} \right)_{\text{Solid}}$$

*i.e.* solid sphere will take less time so it will reach the bottom first

71 (b)

Centre of mass is closer to massive part of the body therefore the bottom piece of bat has larger mass

72 (b)

From adjoining figure the component of momentum along  $x$ -axis (parallel to the wall of container) remains unchanged even after the collision.

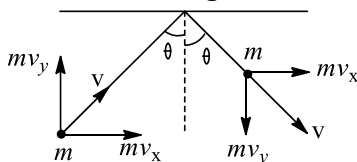

$\therefore$  Impulse = change in momentum of gas molecule along y-axis, i.e., in a direction normal to the wall =  $2mv, = 2mv \cos \theta$

73

(b)

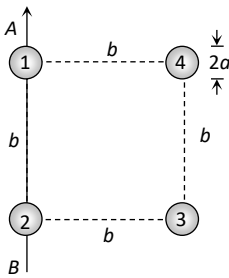

$$I_1 = \frac{2}{5} Ma^2 = \text{M.I. of sphere 1 about AB axis}$$

$$I_2 = \frac{2}{5} Ma^2 = \text{M.I. of sphere 2 about AB axis}$$

$$I_3 = \frac{2}{5} Ma^2 + Mb^2 = \text{M.I. of sphere 3 about AB axis}$$

$$I_4 = \frac{2}{5} Ma^2 + Mb^2 = \text{M.I. of sphere 4 about AB axis}$$

M.I. of system about axis AB

$$I_{\text{system}} = I_1 + I_2 + I_3 + I_4$$

$$= 2 \left( \frac{2}{5} Ma^2 \right) + 2 \left( \frac{2}{5} Ma^2 + Mb^2 \right)$$

$$= \frac{8}{5} Ma^2 + 2Mb^2$$

74

(d)

$$t = \sqrt{\frac{2l(1 + K^2/R^2)}{g \sin \theta}} = \text{same}$$

$$\therefore \frac{2l(1 + K_1^2 + R^2)}{g \sin \theta} = \frac{2l(1 + K_2^2/R^2)}{g \sin \theta_2}$$

For sphere,  $K_1^2 = \frac{2}{5} R^2, \theta_1 = 30^\circ,$

For hollow cylinder,  $K_2^2 = R^2, \theta_2 = ?$

$$\frac{1 + \frac{2}{5}}{\sin 30^\circ} = \frac{1 + 1}{\sin \theta_2}$$

$$\sin \theta_2 = \frac{5}{7} = 0.7143$$

$$\theta = 45^\circ$$

76

(b)

$$\frac{1}{2} MR^2 = MK^2 \Rightarrow K = \frac{R}{\sqrt{2}} = \frac{2.5}{\sqrt{2}} = 1.76 \text{ cm}$$

77

(c)

When spring is massless then according to momentum conservation principle

$$\vec{p}_i = \vec{p}_f \text{ or } 0 = m_1 \vec{v}_1 + m_2 \vec{v}_1$$

$$\therefore m_1 \vec{v}_1 = -m_2 \vec{v}_1$$

$$\therefore m_1 v_1 = m_2 v_2 \text{ or } p_1 = p_2$$

$$\therefore K_1 = \frac{p_1^2}{2m_1}, \quad K_2 = \frac{p_2^2}{2m_2}$$

$$\therefore \frac{K_1}{K_2} = \frac{m_2}{m_1} \quad (\because p_1 = p_2)$$



78

(c)

Let the radii of the thin spherical and the solid sphere are  $R_1$  and  $R_2$  respectively.  
Then the moment of inertia of the spherical shell about their diameter

$$I = \frac{2}{3} MR_1^2 \quad \dots(i)$$

and the moment of inertia of the solid sphere is given by

$$I = \frac{2}{5} MR_2^2 \quad \dots(ii)$$

Given that the masses and moment of inertia for both the bodies are equal, then from Eqs. (i) and (ii)

$$\frac{2}{3} MR_1^2 = \frac{2}{5} MR_2^2 \Rightarrow \frac{R_1^2}{R_2^2} = \frac{3}{5}$$

$$\Rightarrow \frac{R_1}{R_2} = \sqrt{\frac{3}{5}} \Rightarrow R_1 : R_2 = \sqrt{3} : \sqrt{5}$$

79

(c)

As man walks towards axis of rotation. Moment of inertia of system decreases so that angular velocity increases

80

(d)

$$I_z = I_x + I_y$$

$$200 = I_D + I_D = 2I_D$$

$$\therefore I_D = 100g \times cm^2$$

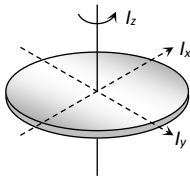

81

(a)

$$\alpha = \frac{\tau}{I} = \frac{1000}{200} = 5 \text{ Rad/sec}^2$$

$$\text{From } \omega = \omega_0 + \alpha t = 0 + 5 \times 3 = 15 \text{ rad/s}$$

83

(c)

Applying the principle of conservation of angular momentum,

$$(I_1 + I_2)\omega = I_1\omega_1 + I_2\omega_2$$

$$(6 + I_2) \frac{400}{60} \times 2\pi = 6 \times \frac{600}{60} \times 2\pi + I_2 \times 0$$

$$\text{Which gives, } I_2 = 3 \text{ kg m}^2$$

84

(a)

The radius of gyration is the distance from the axis of rotation at which if whole mass of the body is supposed to be concentrated.

Here, the whole mass of the equilateral triangle acts at point  $O$ . So the distance  $OA$  is the radius of gyration of this system. Now from triangle  $ADB$



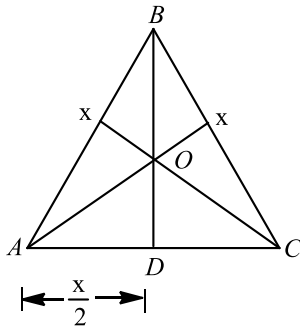

$$x^2 = BD^2 + \left(\frac{x}{2}\right)^2$$

$$\text{or } BD^2 = x^2 - \frac{x^2}{4}$$

$$\text{or } BD^2 = \frac{3x^2}{4}$$

$$\text{or } BD = \sqrt{3} \frac{x}{2}$$

Hence, the distance,  $OB = \frac{\sqrt{3}x}{2} \times \frac{2}{3}$

$$\Rightarrow OB = \frac{x}{\sqrt{3}}$$

But, the distances  $OA, OB$  and  $OC$  are the same.

$$\text{So, } OA = \frac{x}{\sqrt{3}}$$

Hence, the radius of gyration of this system is  $\frac{x}{\sqrt{3}}$ .

85 **(c)**

When body of mass  $m$  slides down an inclined plane then  $v = \sqrt{2gh}$

When it is in the form of ring then,

$$v_{Ring} = \sqrt{\frac{2gh}{\left(1 + \frac{K^2}{R^2}\right)}} = \sqrt{\frac{2gh}{1 + 1}} = \frac{\sqrt{2gh}}{\sqrt{2}} = \frac{v}{\sqrt{2}}$$

86 **(a)**

Since there is no external force acting on the particle,

Hence

$$y_{CM} = \frac{m_1 y_1 + m_2 y_2}{m_1 + m_2} = 0, \text{ hence}$$

$$\left(\frac{m}{4}\right) \times (+15) + \left(\frac{3m}{4}\right) (y_2) = 0 \Rightarrow y_2 = -5 \text{ cm}$$

87 **(a)**

As initially both the particles were at rest therefore velocity of centre of mass was zero and there is no external force on the system so speed of centre of mass remains constant *ie*, it should be equal to zero.

88 **(a)**

It's always in axial direction

89 **(b)**

To reverse the direction  $\int \tau d\theta = 0$  (work done is zero)

$$\tau = (20t - 5t^2)2 = 40t - 10t^2$$

$$\alpha = \frac{\tau}{I} = \frac{40t - 10t^2}{10} = 4t - t^2$$

$$\omega = \int_0^t \alpha dt = 2t^2 - \frac{t^3}{3}$$



$\omega$  is zero at

$$2t^2 - \frac{t^3}{3} = 0 \Rightarrow t^3 = 6t^2 \Rightarrow t = 6 \text{ sec}$$

$$\theta = \int \omega dt = \int_0^6 \left( 2t^2 - \frac{t^3}{3} \right) dt$$

$$= \left[ \frac{2t^3}{3} - \frac{t^4}{12} \right]_0^6 = 216 \left[ \frac{2}{3} - \frac{1}{2} \right] = 36 \text{ rad}$$

No. of revolution  $\frac{36}{2\pi}$  is less than 6

90 **(c)**

A couple consists of two equal and opposite forces acting at a separation, so that net force becomes zero. When a couple acts on a body it rotates the body but does not produce any translatory motion. Hence, only rotational motion is produced.

91 **(a)**

$$\alpha = \frac{2\pi(n_2 - n_1)}{t} = \frac{2\pi(0 - 20)}{10} = -4\pi \text{ rad/s}^2$$

Negative sign means retardation

$$\text{Now } \tau = I\alpha = 5 \times 10^{-3} \times 4\pi = 2\pi \times 10^{-2} \text{ N} - m$$

92 **(d)**

For a ring  $K^2 = r^2$  then

$$v^2 = \sqrt{\frac{2gh}{1 + \frac{K^2}{r^2}}}$$

$$\therefore v^2 = \frac{2gh}{2} = gh$$

$$v = \sqrt{gh}$$

93 **(d)**

$$\text{Angular speed } \omega = \frac{v}{R} = \frac{5.29}{0.15} = 34 \text{ rad/s}$$

94 **(b)**

$$\frac{1}{2} I \omega^2 = 40\% \text{ of } \frac{1}{2} m v^2$$

$$\frac{1}{2} I \omega^2 = \frac{40}{100} \left( \frac{1}{2} m r^2 \omega^2 \right)$$

$$I = \frac{2}{5} m r^2$$

So, the body is solid sphere.

95 **(c)**

When hollow cylinder slides with out rolling, it possess only translational kinetic energy,  $K_T = \frac{1}{2} m v^2$

When it rolls without slipping, it possess both types of kinetic energy,

$$K_N = \frac{1}{2} m v^2 \left( 1 + \frac{K^2}{R^2} \right)$$

$$\therefore \frac{K_T}{K_N} = \frac{1}{\left( 1 + \frac{K^2}{R^2} \right)} = \frac{1}{2} \quad [\text{For hollow cylinder } \frac{K^2}{R^2} = 1]$$

96 **(a)**

As a real velocity of comet is constant, therefore,

$$r_1 v_1 = r_2 v_2 \text{ or } v_2 = \frac{r_1 v_1}{r_2}$$



$$= \frac{6 \times 10^{10} \times 7 \times 10^4}{1.4 \times 10^{12}} = 3 \times 10^3 \text{ms}^{-1}$$

- 97 **(c)**  
As the body is rigid therefore angular velocity of all particles will be same *i. e.*  $\omega = \text{constant}$

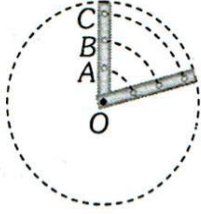

From  $v = r\omega, v \propto r$  (if  $\omega = \text{constant}$ )

It means linear velocity of that particle will be more, whose distance from the centre is more, *i. e.*  $v_A < v_B < v_C$  but  $\omega_A = \omega_B = \omega_C$

- 100 **(b)**  
As net horizontal force acting on the system is zero, hence momentum must remain conserved. Hence  
 $mu + 0 = 0 + mv_2 \Rightarrow v_2 = \frac{mu}{M}$

As per definition,

$$e = -\frac{(v_1 - v_2)}{(u_2 - u_1)} = \frac{v_2 - 0}{0 - u} = \frac{v_2}{u} = \frac{\frac{mu}{M}}{u} = \frac{m}{M}$$

- 101 **(d)**  
 $K_R = \frac{1}{2}I\omega^2 = \frac{1}{2} \times \left(\frac{2}{5}MR^2\right) \times (50)^2$   
 $= \frac{1}{2} \times \frac{2}{5} \times 1 \times (0.03)^2 \times (50)^2 = \frac{9}{20} \text{J}$

- 102 **(d)**  
According to conservation of angular momentum,

$$I\omega = \text{constant}$$

*ie,* we can write

$$I_1\omega_1 = I_2\omega_2$$

$$\text{or } MR^2\omega = (M + 4m)R^2\omega_2$$

$$\text{or } \omega_2 = \left(\frac{M}{M+4m}\right)\omega$$

- 103 **(a)**  
 $\omega = \omega_0 + \alpha t$   
 $\Rightarrow \omega = 0 + \alpha t$   
 $\Rightarrow \alpha = \frac{15}{0.270} \text{rads}^{-2}$

$$\text{Now, } a = r\alpha = 0.81 \times \frac{15}{0.270} = 45 \text{ms}^{-2}$$

- 104 **(a)**  
Angular momentum of system remains constant

$$I \propto \frac{1}{\omega} \Rightarrow \frac{I_2}{I_1} = \frac{\omega_1}{\omega_2} = \frac{20}{10} \Rightarrow I_2 = 2I_1 = 2I$$

- 105 **(d)**  
Centre of mass  $C_1$  of the point masses placed at corners  $P$  and  $S$  from point  $P$



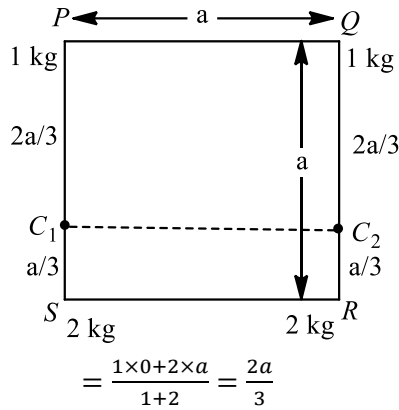

Therefore, distance of centre of mass  $C_1$  from point  $S$

$$= a - \frac{2a}{3} = \frac{a}{3}$$

Similarly, centre of mass  $C_2$  of point masses placed at corners  $Q$  and  $R$ , from point  $Q = \frac{2a}{3}$

Distance of centre of mass  $C_2$  from point  $R = a - \frac{2a}{3} = \frac{a}{3}$

Centre of mass of all four point masses is at the mid point of the line joining  $C_1$  and  $C_2$ , which is farthest from points  $P$  and  $Q$ .

106

(b)

Using conservation of angular momentum

$$\left(\frac{1}{2}mR^2\right)\omega = \left\{\frac{1}{2}mR^2 + \frac{1}{2}\left(\frac{m}{4}\right)R^2\right\}\omega'$$

$$\left(\frac{1}{2}mR^2\right)\omega = \frac{5}{8}mR^2\omega'$$

$$\omega' = \frac{4}{5}\omega$$

107

(a)

$$v = \frac{\sqrt{2gh}}{\sqrt{1 + \frac{K^2}{R^2}}} = \frac{\sqrt{2 \times 10 \times 2}}{\sqrt{1 + \frac{1}{2}}} = \sqrt{26.66} = 5.29 \text{ m/s approx}$$

108

(b)

In this process potential energy of the metre stick will be converted into rotational kinetic energy

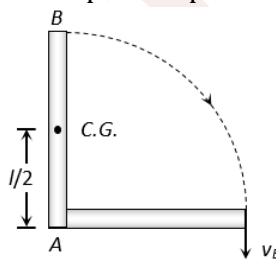

$$\text{P.E. of metre stick} = mg \left(\frac{l}{2}\right)$$

Because its centre of gravity lies at the middle point of the rod

$$\text{Rotational kinetic energy } E = \frac{1}{2}I\omega^2$$

$$I = \text{M.I. of metre stick about point } A = \frac{ml^2}{3}$$

$\omega$  = Angular speed of the rod while striking the ground

$v_B$  = Velocity of end  $B$  of metre stick while striking the ground

By the law of conservation of energy,

$$mg \left(\frac{l}{2}\right) = \frac{1}{2}I\omega^2 = \frac{1}{2} \frac{ml^2}{3} \left(\frac{v_B}{l}\right)^2$$



By solving we get,  $v_B = \sqrt{3gl} = \sqrt{3 \times 10 \times 1} = 5.4 \text{ m/s}$

109 **(b)**

Depends on the distribution of mass in the body

110 **(c)**

$$mv - mv = (m + m)v$$

$$v = 0$$

111 **(b)**

When a body of mass  $m$  and radius  $R$  rolls down on inclined plane of height  $h$  and angle of inclination  $\theta$ , it losses potential energy. However, it acquires both linear and angular speeds.

$$\text{Velocity at the lowest point } v = \sqrt{\frac{2gh}{1 + \frac{K^2}{R^2}}}$$

$$\text{For solid sphere } \frac{K^2}{R^2} = \frac{2}{5}$$

$$\therefore v = \sqrt{\frac{2 \times 10 \times 7}{1 + \frac{2}{5}}} = 10 \text{ m/s}$$

112 **(c)**

To keep the centre of mass at the position, velocity of centre of mass is zero, so

$$\frac{m_1 v_1 + m_2 v_2}{m_1 + m_2} = 0$$

where  $\mathbf{v}_1$  and  $\mathbf{v}_2$  are velocities of particles 1 and 2 respectively.

$$\Rightarrow m_1 \frac{dr_1}{dt} + m_2 \frac{dr_2}{dt} = 0$$

$$[\because \mathbf{v}_1 = \frac{d\mathbf{r}_1}{dt} \text{ and } \mathbf{v}_2 = \frac{d\mathbf{r}_2}{dt}]$$

$$\Rightarrow m d\mathbf{r}_1 + m_2 d\mathbf{r}_2 = 0 \text{ [} d\mathbf{r}_1 \text{ and } d\mathbf{r}_2 \text{ represent the change in displacement of particles]}$$

Let 2nd particle has been displaced by distance  $x$ .

$$\Rightarrow m_1(d) + m_2(x) = 0$$

$$\Rightarrow x = -\frac{m_1 d}{m_2}$$

Negative sign shows that both the particles have to move in opposite directions.

So,  $\frac{m_1 d}{m_2}$  is the distance moved by 2nd particle to keep centre of mass at the same position.

113 **(a)**

$$L = I\omega \therefore L \propto \omega \text{ (If } I = \text{constant)}$$

So graph between  $L$  and  $\omega$  will be straight line with constant slope

114 **(d)**

$$K_R = \frac{1}{2} I \omega^2 = \frac{1}{2} m r^2 \omega^2$$

115 **(c)**

If initial velocity of bullet be  $v$  then after collision combined velocity of bullet and target is

$$v' = \frac{mv}{(M+v)} \text{ and } h = \frac{v'^2}{2g} \text{ or } v' = \sqrt{2gh}$$

$$\therefore \frac{mv}{(M+m)} = \sqrt{2gh}$$

$$\Rightarrow v = \left(\frac{M+m}{m}\right) \cdot \sqrt{2gh} = \left(1 + \frac{M}{m}\right) \sqrt{2gh}$$

116 **(b)**

Torque zero means,  $\alpha$  zero

$$\therefore \frac{d^2\theta}{dt^2} = 0 \Rightarrow 12t - 12 = 0$$



$\therefore t = 1$  second

117 (c)

$v_t$  = velocity due to translational motion

$v_R$  = velocity due to rotational motion

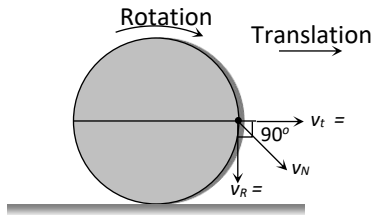

$$v_N = \sqrt{v_t^2 + v_R^2} = \sqrt{v^2 + v^2} = \sqrt{2}v = 2\sqrt{2}m/s$$

118 (d)

Position vector of the point at which force is acting

$$\vec{r}_1 = \hat{i} + 2\hat{j} + 3\hat{k}$$

But we have to calculate the torque about another point. So its position vector about that another point

$$\vec{r}_1 = \vec{r}_1 - \vec{r}_2 = (\hat{i} + 2\hat{j} + 3\hat{k}) - (3\hat{i} - 2\hat{j} - 3\hat{k})$$

$$= -2\hat{i} + 4\hat{j} + 6\hat{k}$$

$$\text{Now, } \vec{\tau} = \vec{r}_1 \times \vec{F} = (-2\hat{i} + 4\hat{j} + 6\hat{k}) \times (4\hat{i} - 5\hat{j} + 3\hat{k})$$

$$\vec{\tau} = \begin{vmatrix} \hat{i} & \hat{j} & \hat{k} \\ -2 & 4 & 6 \\ 4 & -5 & 3 \end{vmatrix} = \hat{i}(12 + 30) - \hat{j}(-6 - 24) + \hat{k}(10 - 16)$$

$$= (42\hat{i} + 30\hat{j} - 6\hat{k})N - m$$

119 (d)

$$x_{cm} = \frac{\int x dm}{\int dm}, x_{cm} = \frac{\int_0^L x k \left(\frac{x}{L}\right)^n dx}{\int_0^L k \left(\frac{x}{L}\right)^n dx} = \frac{(n+1)}{(n+2)}L$$

120 (c)

$$I_s = \frac{2}{5}MR_s^2, I_h = \frac{2}{3}MR_h^2$$

$$\text{As, } I_s = I_h$$

$$\therefore \frac{2}{5}MR_s^2 = \frac{2}{3}MR_h^2$$

$$\therefore \frac{R_s}{R_h} = \frac{\sqrt{5}}{\sqrt{3}}$$

121 (d)

Mass of disc (X),  $m_X = \pi R^2 t \rho$

Where,  $\rho$  = density of material of disc

$$\therefore I_X = \frac{1}{2}m_X R^2 = \frac{1}{2}\pi R^2 t \rho R^2$$

$$I_X = \frac{1}{2}\pi \rho t R^4 \quad \dots(i)$$

Mass of disc (Y)

$$m_Y = \pi(4R)^2 \frac{t}{4} \rho = 4\pi R^2 t \rho$$

$$\text{and } I_Y = \frac{1}{2}m_Y(4R)^2 = \frac{1}{2}4\pi R^2 \rho t \cdot 16R^2$$

$$\Rightarrow I_Y = 32\pi t \rho R^4 \quad \dots(ii)$$



$$\therefore \frac{I_Y}{I_X} = \frac{32\pi\rho R^4}{\frac{1}{2}\pi\rho t R^4} = 64$$

$$\therefore I_Y = 64 I_X$$

123

(a)

$$m_1 = 1 \text{ kg}, m_2 = 2 \text{ kg}, m_3 = 3 \text{ kg}$$

Position of centre of mass (2, 2, 2,)

$$m_4 = 4 \text{ kg}$$

New position of centre of mass (0, 0, 0).

For initial position

$$X_{CM} = \frac{m_1x_1 + m_2x_2 + m_3x_3}{m_1 + m_2 + m_3}$$

$$2 = \frac{m_1x_1 + m_2x_2 + m_3x_3}{1 + 2 + 3}$$

$$m_1x_1 + m_2x_2 + m_3x_3 = 12$$

Similarly,  $m_1y_1 + m_2y_2 + m_3y_3 = 12$

and  $m_1z_1 + m_2z_2 + m_3z_3 = 12$

For new position,

$$X'_{CM} = \frac{m_1x_1 + m_2x_2 + m_3x_3 + m_4x_4}{m_1 + m_2 + m_3 + m_4}$$

$$0 = \frac{12 + 4x_4}{1 + 2 + 3 + 4}$$

$$4x_4 = -12$$

$$x_4 = -3$$

Similarly,  $y_4 = -3$

$$z_4 = -3$$

$\therefore$  Position of fourth mass (-3, -3, -3)

124

(b)

As body is moving on a frictionless surface. Its mechanical energy is conserved. When body climbs up the inclined plane it keeps on rotating with same angular speed, as no friction force is present to provide retarding torque so

$$\frac{1}{2}I\omega^2 + \frac{1}{2}mv^2 \geq \frac{1}{2}I\omega^2 + mgh \Rightarrow v \geq \sqrt{2gh}$$

125

(c)

Since gun-shot system is an isolated closed system, its centre of mass must remain at rest.

126

(c)

$$\text{KE of rotation} = \frac{1}{2}I\omega^2 = \frac{1}{2} \times \frac{2}{5}MR^2(2\pi n)^2$$

$$= \frac{1}{5} \times 4\pi^2 n^2 MR^2$$

$$= 0.8\pi^2 \left(\frac{600}{60}\right)^2 MR^2 = 80\pi^2 MR^2$$

127

(d)

Centre of mass of a stick lies at the mid point and when the stick is displaced through an angle  $60^\circ$  it rises upto height 'h' from the initial position

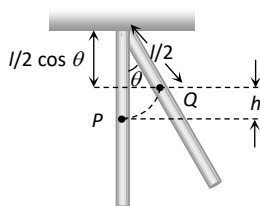

$$\text{From the figure } h = \frac{l}{2} - \frac{l}{2} \cos \theta = \frac{l}{2}(1 - \cos \theta)$$



Hence the increment in potential energy of the stick =  $mgh = mg \frac{l}{2}(1 - \cos \theta) = 0.4 \times 10 \times \frac{1}{2}(1 - \cos 60^\circ) = 1J$

128 (a)

$$\text{K.E.} = \frac{L^2}{2I}$$

∴ From angular momentum conservation about centre

$L \rightarrow \text{constant}$

$$I = mr^2$$

$$\text{K.E.'} = \frac{L^2}{2(mr'^2)} \quad r' = \frac{r}{2}$$

$$\text{K.E.'} = 4 \text{ K.E.}$$

K.E. is increased by a factor of 4

129 (a)

The velocity of a body in different reference frames may be same or different. So, momentum and kinetic energy of a body may be same or different in different reference frames

130 (b)

Speed of the bullet relative to ground  $\vec{v}_b = \vec{v} + \vec{v}_r$ , where  $v_r$  is recoil velocity of gun. Now for gun-bullet system applying the conservation law of momentum, we get

$$m\vec{v}_b + M\vec{v}_r = 0 \text{ or } m(\vec{v} + \vec{v}_r) + M\vec{v}_r = 0$$

$$\Rightarrow \vec{v}_r = -\frac{m\vec{v}}{m+M} \text{ or } v_r = \frac{mv}{m+M}$$

131 (d)

For any uniform rod, the mass is concentrated at its centre

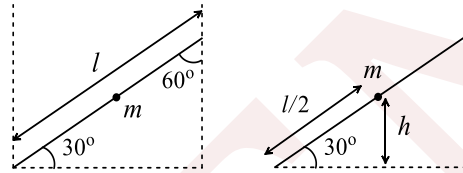

Height of the mass from ground is,  $h = (l/2) \sin 30^\circ$

Potential energy of the rod =  $mgh$

$$= m \times g \times \frac{l}{2} \sin 30^\circ = m \times g \times \frac{l}{2} \times \frac{1}{2} = \frac{mgl}{4}$$

132 (c)

$$\frac{\text{Rotational kinetic energy}}{\text{Translatory kinetic energy}} = \frac{\frac{1}{2}mv^2 \frac{K^2}{R^2}}{\frac{1}{2}mv^2} = \frac{K^2}{R^2} = \frac{2}{5}$$

133 (d)

In the absence of external torque for a body revolving about any axis, the angular momentum remains constant. This is known as law of conservation of angular momentum,  $\vec{\tau} = \frac{d\vec{L}}{dt}$

As  $\vec{\tau} = 0 \therefore \frac{d\vec{L}}{dt} = 0$  or  $\vec{L} = \text{constant}$

134 (b)

$$\text{Using } a = \frac{g}{1 + \frac{I}{mR^2}}$$

$$a = \frac{g}{1 + \frac{MR^2}{2mR^2}} \quad \left[ I = \frac{1}{2}MR^2 \right]$$



$$\Rightarrow a = \frac{2m}{M + 2m}g$$

135 (c)

Let the mass of an element of length  $dx$  of the rod located at a distance  $x$  away from left end is  $\frac{M}{L}dx$ .

The  $x$ - coordinate of the centre of mass is given by

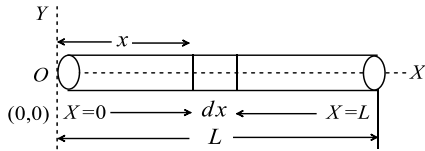

$$\text{Total mass of rod} = \int_0^L Ax dx = \frac{AL^2}{2}$$

$$X_{cm} = \frac{1}{M} \int x dm = \frac{1}{\left(\frac{AL^2}{2}\right)} \int_0^L x (Ax dx)$$

$$= \frac{2A}{AL^2} \left[ \frac{x^3}{3} \right]_0^L = \left[ \frac{2}{L^2} \right] \left[ \frac{L^3}{3} \right] = \frac{2L}{3}$$

Hence, the centre of mass is at  $\left(\frac{2L}{3}, 0, 0\right)$

136 (d)

From  $E = \frac{1}{2}r\omega^2$ , we find that when frequency ( $n$ ) is doubled,  $\omega = 2\pi n$  is doubled,  $\omega^2$  becomes 4 times. As  $E$  reduces to half,  $I$  must have been reduced to  $\frac{1}{8}$ th. From  $L = I\omega$ ,  $L$  becomes  $\frac{1}{8} \times 2 = \frac{1}{4}$  times ie,  $0.25 L$

138 (a)

$$I = MK^2 = \frac{ML^2}{12}$$

$$\therefore K = \frac{L}{\sqrt{12}}$$

139 (d)

Here,  $l = 1\text{m}$ ,  $\theta = 30^\circ$ ,  $g = 9.81 \text{ ms}^{-2}$ ,  $t = ?$

$$t = \sqrt{\frac{2l(1 + K^2/R^2)}{g \sin \theta}}$$

For a rupee coin,  $K^2 = \frac{1}{2}R^2$

$$t = \sqrt{\frac{2 \times 1(1 + 1/2)}{9.81 \sin 30^\circ}} = \sqrt{\frac{6}{9.81}} = 0.78 \text{ s}$$

140 (a)

$$\frac{2}{5}MR^2 = \frac{3}{2}Mr^2 \Rightarrow r = \frac{2R}{\sqrt{15}}$$

141 (c)

The situation is shown in figure

$$I_{xx'} = m \times DP^2 + m \times BQ^2 + m \times CA^2$$



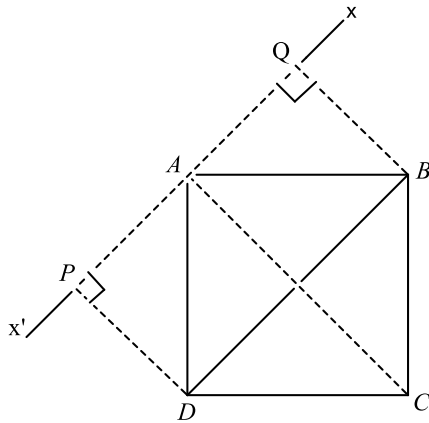

$$= m \times 2 \times \left(\frac{\sqrt{2}l}{2}\right)^2 + m \times (\sqrt{2}l)^2$$

$$= 3ml^2$$

143 (b)

(a) This is only possible when collision is head on elastic.

(b) When collision is oblique elastic, then in this case, both bodies move perpendicular to each other after collision

(c) Since, in elastic collision, kinetic energy of system remains constant so, this is not possible.

(d) The same reason as (b).

144 (b)

$$I_{CM} = \frac{ML^2}{12} \quad (\text{about middle point})$$

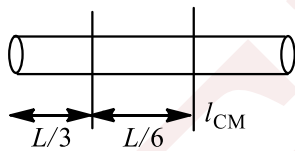

$$\therefore I = I_{CM} + Mx^2$$

$$= \frac{ML^2}{12} + M\left(\frac{L}{6}\right)^2$$

$$I = \frac{ML^2}{9}$$

145 (a)

Because its M.I. (or value of  $\frac{K^2}{R^2}$ ) is minimum for sphere

146 (c)

$$\therefore \vec{a}_{CM} = \frac{\vec{F}_{eq}}{(m_1 + m_2 + m_3)} = \frac{m_1\vec{a}_1 + m_2\vec{a}_2 + m_3\vec{a}_3}{(m_1 + m_2 + m_3)}$$

$$\therefore \vec{F}_{eq} = m_1\vec{a}_1 + m_2\vec{a}_2 + m_3\vec{a}_3$$

$$= 1 \times 1 + 2 \times 2 + 4 \times (-0.5) = 1 + 4 - 2 = 3 \text{ N}$$

147 (b)

Since there is no external force acting on rifle bullet system, hence

$$p_b = p_g \text{ and hence } \frac{K_b}{K_g} = \frac{m_g}{m_b} = \frac{2\text{kg}}{50\text{g}} = \frac{4}{1}$$

$$\text{Or } K_g = \frac{K_b}{4}$$



Now total energy  $K_b + K_g$  or  $+\frac{K_b}{40} = \frac{41}{40}, K_b = 2050$

$$\Rightarrow K_b = \frac{2050 \times 40}{41} = 2000\text{J}$$

And  $K_g = 2050 - 2000 = 50\text{J}$ .

148

**(d)**

$$I = \frac{2}{5}mr^2 = mk^2$$

$$k^2 = \frac{2}{5}r^2 \Rightarrow k = r\sqrt{0.4}$$

150

**(b)**

As  $\tau = I\alpha$

$$\alpha \propto \frac{1}{I} \quad (\tau \text{ is constant})$$

$MI$  of figure (ii) is smaller hence acceleration is greater

151

**(b)**

Moment of inertia of triangle sheet  $ABC$  about  $AC = \frac{1}{2}$  moment of inertia of square  $ABCD$  about  $AC$

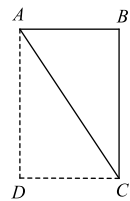

$$\frac{1}{2}(2M) \frac{l^2}{12} = \frac{Ml^2}{12}$$

152

**(c)**

$$I = 2MR^2 = 2 \times 3 \times (1)^2 = 6g - cm^2$$

153

**(a)**

Force does not produce any torque because it passes through the centre (Point of rotation) and we know that if  $\tau = 0$  then  $L = \text{constant}$

154

**(b)**

Here,  $m = 8 \text{ kg}, r = 40 \text{ cm} = \frac{2}{5} \text{ m},$

$$\omega = 12 \text{ rad s}^{-1}, I = 0.64 \text{ kg m}^2$$

$$\text{Total KE} = \frac{1}{2}I\omega^2 + \frac{1}{2}mv^2$$

$$= \frac{1}{2}I\omega^2 + \frac{1}{2}mr^2\omega^2$$

$$= \frac{1}{2} \times 0.64 \times 15^2 + \frac{1}{2} \times 8 \times \left(\frac{2}{5}\right)^2 \times 15^2 = 216 \text{ J}$$

155

**(d)**

Moment of inertia of a hollow cylinder of mass  $M$  and radius  $r$  about its own axis is  $Mr^2$

156

**(a)**

Given system of two particles will rotate about its centre of mass

$$\text{Initial angular momentum} = MV \left(\frac{L}{2}\right)$$

$$\text{Final angular momentum} = 2I\omega = 2M \left(\frac{L}{2}\right)^2 \omega$$

By the law of conservation of angular momentum

$$MV \left(\frac{L}{2}\right) = 2M \left(\frac{L}{2}\right)^2 \omega \Rightarrow \omega = \frac{V}{L}$$

157

**(d)**



As  $\omega_2 = \omega_1 + \alpha t \therefore 40\pi = 20\pi + \alpha \times 10$

or  $\alpha = 2\pi \text{ rads}^{-1}$

From,  $\omega_2^2 - \omega_1^2 = 2\alpha\theta$

$(40\pi)^2 - (20\pi)^2 = 2 \times 2\pi\theta, \Rightarrow \theta = \frac{1200\pi^2}{4\pi} = 300\pi$

Number of rotations completed

$= \frac{\theta}{2\pi} = \frac{300}{2\pi} = 150$

158 **(a)**

First sphere will take a time  $t_1$ , to start motion in second sphere on colliding with it, where  $t_1 = \frac{L}{u}$

Now speed of second sphere will be

$v_2 = \frac{u}{2}(1 + e) = \frac{2}{3}u$

Hence time taken by second sphere to start motion in third sphere  $t_2 = \frac{L}{2/3u} = \frac{3L}{2u}$

$\therefore$  Total time  $t = t_1 + t_2 = \frac{L}{u} + \frac{3L}{2u} = \frac{5L}{2u}$

159 **(b)**

$\frac{1}{2}I\omega^2 = 750J \Rightarrow \omega^2 = \frac{750 \times 2}{2.4} = 625 \Rightarrow \omega = 25 \text{ rad/s}$

$\alpha = \frac{\omega_2 - \omega_1}{t} \Rightarrow 5 = \frac{25 - 0}{t} \Rightarrow t = 5 \text{ s}$

160 **(b)**

$E = K_R = \frac{1}{2}I\omega^2$

If angular velocities are equal then  $E \propto I$

As  $I_1 > I_2$  therefore  $E_1 > E_2$

161 **(c)**

$I_1\omega_1 = I_2\omega_2 \therefore \frac{\omega_1}{\omega_2} = \frac{I_2}{I_1}$

Now,  $\frac{E_1}{E_2} = \frac{\frac{1}{2}I_1\omega_1^2}{\frac{1}{2}I_2\omega_2^2} = \frac{I_1}{I_2} \times \left(\frac{I_2}{I_1}\right)^2 = \frac{I_2}{I_1}$

As  $I_1 > I_2 \therefore E_1 < E_2$

162 **(d)**

$m_1 = 2 \text{ kg}, m_2 = 4 \text{ kg}, \vec{v}_1 = 20 \text{ m/s}, \vec{v}_2 = -10 \text{ m/s}$

$\vec{v}_{cm} = \frac{m_1\vec{v}_1 + m_2\vec{v}_2}{m_1 + m_2} = \frac{2 \times 20 - 4 \times 10}{2 + 4} = 0 \text{ m/s}$

163 **(b)**

$\frac{K_1}{K_2} = \frac{\frac{p_1^2}{2m_1}}{\frac{p_2^2}{2m_2}} = \frac{m_2}{m_1} = \frac{4m}{m} = 4:1 \quad (\because p_1 = p_2)$

164 **(d)**

When the hands outstretched, moment of inertia increases and angular velocity decreases so that angular momentum remains unchanged

165 **(d)**

$K_T = K_R \Rightarrow \frac{1}{2}mv^2 = \frac{1}{2}mv^2 \left(\frac{K^2}{R^2}\right) \Rightarrow \frac{K^2}{R^2} = 1$

This value of  $K^2/R^2$  match with hollow cylinder



166

(b)

Let  $m_1 = m, m_2 = 2m, m_3 = 3m, m_4 = 4m$

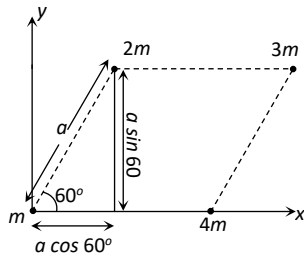

$$\vec{r}_1 = 0\hat{i} + 0\hat{j}$$

$$\vec{r}_2 = a \cos 60^\circ \hat{i} + a \sin 60^\circ \hat{j} = \frac{a}{2} \hat{i} + \frac{a\sqrt{3}}{2} \hat{j}$$

$$\vec{r}_3 = (a + a \cos 60^\circ) \hat{i} + a \sin 60^\circ \hat{j} = \frac{3}{2} a \hat{i} + \frac{a\sqrt{3}}{2} \hat{j}$$

$$\vec{r}_4 = a \hat{i} + 0\hat{j}$$

By substituting above value in the following formula

$$\vec{r} = \frac{m_1 \vec{r}_1 + m_2 \vec{r}_2 + m_3 \vec{r}_3 + m_4 \vec{r}_4}{m_1 + m_2 + m_3 + m_4} = 0.95a \hat{i} + \frac{\sqrt{3}}{4} a \hat{j}$$

So the location of centre of mass  $\left[0.95a, \frac{\sqrt{3}}{4} a\right]$

168

(c)

Given,  $MI = 2.5 \text{ kgm}^{-2}$

$$W = 40 \text{ rad s}^{-1}$$

$$T = 10 \text{ Nm}$$

As  $T = I\alpha$

$$10 = 2.5\alpha$$

$$\alpha = 4 \text{ rad s}^{-2}$$

Now,  $\omega = \omega_0 + \alpha t$

$$60 = 40 + 4 \times t$$

$$20 = 4t$$

$$t = 5 \text{ s}$$

169

(a)

Weight of the rod =  $w$

$$\text{Reaction of boy } R_B = \frac{w}{4}$$

$$\text{Reaction of man } R_M = \frac{3w}{4}$$

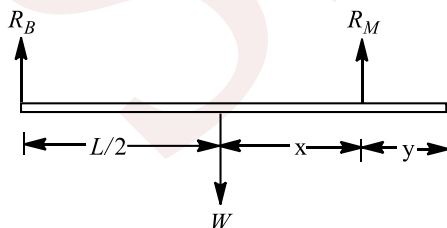

As the rod is in rotational equilibrium

$$\therefore \sum \tau = 0$$

$$R_B \times \frac{L}{2} - R_M \times x = 0$$

$$\Rightarrow \frac{w}{4} \times \frac{L}{2} - \frac{3w}{4} \times x = 0$$



$$\Rightarrow x = \frac{L}{6}$$

$$\therefore \text{Distance from other end, } y = \frac{L}{2} - x$$

$$\Rightarrow y = \frac{L}{2} - \frac{L}{6} = \frac{2L}{6} = \frac{L}{3}$$

170 (d)

$$\frac{1}{2}mv^2 \left( \frac{K^2}{R^2} \right) = 40\% \frac{1}{2}mv^2 \Rightarrow \therefore \frac{K^2}{R^2} = \frac{40}{100} = \frac{2}{5}$$

i. e. the body is solid sphere

171 (b)

Moment of inertia the rotational inertia of an object.

Moment of inertia of circular ring about an axis passing through its centre and perpendicular to its plane is

$$I_{\text{ring}} = MR^2$$

Similarly, for a circular disc about the same axis of rotation

$$I_{\text{disc}} = \frac{1}{2}MR^2$$

$$\text{Hence, } \frac{I_{\text{ring}}}{I_{\text{disc}}} = \frac{MR^2}{\frac{1}{2}MR^2} = \frac{2}{1}$$

172 (d)

$$\begin{aligned} I &= I_{CM} + Mx^2 \\ &= \frac{ML^2}{12} + M \left[ \frac{L}{4} \right]^2 \\ &= \frac{ML^2}{12} + \frac{ML^2}{16} = \frac{7ML^2}{48} \end{aligned}$$

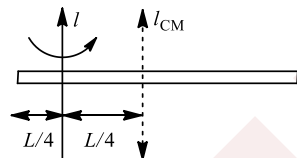

173 (a)

$$\begin{aligned} I &= I_1 - I_2 = \frac{9MR^2}{2} - \frac{MR^2}{18} \\ &= \frac{81MR^2 - MR^2}{18} = \frac{40MR^2}{9} \end{aligned}$$

175 (b)

$$\begin{aligned} K_R &= \frac{1}{2}I\omega^2 = \frac{1}{2} \left( \frac{1}{2}MR^2 \right) (2\pi n)^2 \\ &= \frac{1}{2} \left( \frac{1}{2} \times 72 \times (0.5)^2 \right) \times 4\pi^2 \times \left( \frac{70}{60} \right)^2 = 240 \text{ J} \end{aligned}$$

176 (d)

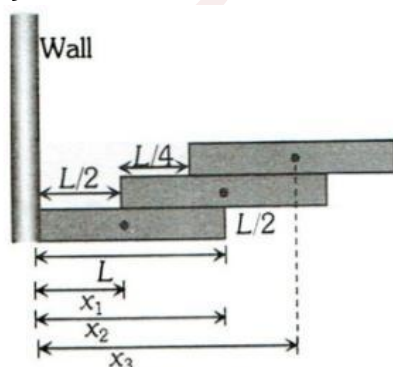

From figure,  $x_1 = \frac{L}{2}, x_2 = \frac{L}{2} + \frac{L}{2} = L$

$$x_3 = \frac{L}{2} + \frac{L}{4} + \frac{L}{2} = \frac{5L}{4}$$

$$\begin{aligned} \therefore X_{CM} &= \frac{m_1 x_1 + m_2 x_2 + m_3 x_3}{m_1 + m_2 + m_3} \\ &= \frac{M \times \frac{L}{2} + M \times L + M \times \frac{5L}{4}}{M + M + M} = \frac{\frac{11}{4}ML}{3M} = \frac{11L}{12} \end{aligned}$$

177

(c)

$$m_1 = 12, m_2 = 16$$

$$\vec{r}_1 = 0\hat{i} + 0\hat{j}, r_2 = 1.1\hat{i} + 0\hat{j}$$

$$\vec{r} = \frac{m_1 \vec{r}_1 + m_2 \vec{r}_2}{m_1 + m_2}$$

$$\vec{r} = \frac{16 \times 1.1}{28} \hat{i} = 0.63\hat{i} \text{ i.e. } 0.36\text{\AA} \text{ from carbon atom}$$

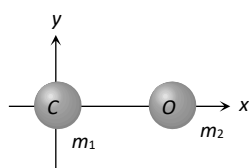

178

(c)

For translator motion the force should be applied on the centre of mass of the body so we have to calculate the location of centre of mass of  $T$  shaped object.

Let mass of rod  $AB$  is  $m$  so the mass of rod  $CD$  will be  $2m$ .

Let  $y_1$  is the centre of mass of rod  $AB$  and  $y_2$  is the centre of mass of rod  $CD$ . We can consider that whole mass of the rod is placed at their respective centre of mass i.e., mass  $m$  is placed at  $y_1$  and mass  $2m$  is placed at  $y_2$ .

Taking point  $c$  at the origin position vector of points  $y_1$  and  $y_2$  can be written as

$$\mathbf{r}_1 = 2l\mathbf{j}, \mathbf{r}_2 = l\mathbf{j}$$

and  $m_1 = m$  and  $m_2 = 2m$

Position vector of centre of mass of the system

$$r_{CM} = \frac{m_1 \mathbf{r}_1 + m_2 \mathbf{r}_2}{m + m_2} = \frac{m2l\mathbf{j} + 2ml\mathbf{j}}{m + 2m} = \frac{4ml\mathbf{j}}{3m} = \frac{4l\mathbf{j}}{3}$$

180

(a)

$$x_{cm} = \frac{m_1 x_1 + m_2 x_2}{m_1 + m_2} = \frac{0.4 \times 2 + 0.6 \times 7}{0.4 + 0.6} = 5m$$

181

(c)

Displacement of the man with respect to trolley in 4 sec

$$x_{mT} = 4m \Rightarrow x_{mT} = x_m + x_T \Rightarrow x_T = 4 - x_m$$

Position of centre of mass remain constant

$$\Rightarrow (4 - x_m)320 = x_m \times 80 \Rightarrow x_m = \frac{16}{5} = 3.2 \text{ m}$$

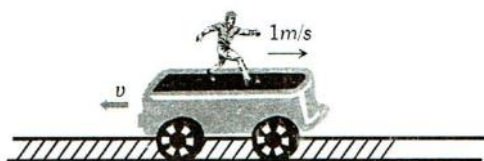

**Alternatively:** If the man starts walking on the trolley in the forward direction then whole system will move in backward direction with same momentum.



Momentum of man in forward direction = Momentum of system (man + trolley) in backward direction

$$\Rightarrow 80 \times 1 = (80 + 320) \times v \Rightarrow v = 0.2 \text{ m/s}$$

So the velocity of man w.r.t. ground  $1.0 - 0.2 = 0.8 \text{ m/s}$

$$\therefore \text{Displacement of man w.r.t. ground} = 0.8 \times 4 = 3.2 \text{ m}$$

182

(a)

When the sphere 1 is released from horizontal position, then from energy conservation, potential energy at height  $l_0$  = kinetic energy at bottom

$$\text{Or } mgl_0 = \frac{1}{2}mv^2$$

$$\text{Or } v = \sqrt{2gl_0}$$

Since, all collisions are elastic, so velocity of sphere 1 is transferred to sphere 2, then from 2 to 3 and finally from 3 to 4. Hence, just after collision, the sphere 4 attains a velocity equal to  $\sqrt{2gl_0}$

183

(d)

Generator axis of a cylinder is a line lying on its surface and parallel to axis of cylinder

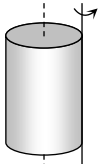

By parallel axis theorem

$$I = \frac{MR^2}{2} + MR^2 = \frac{3}{2}MR^2$$

184

(a)

$$a = \frac{g \sin \theta}{1 + \frac{K^2}{R^2}} = \frac{g \sin \theta}{1 + \frac{2}{5}} = \frac{5}{7}g \sin \theta$$

185

(b)

$$X = \frac{m_1x_1 + m_2x_2 + m_3x_3 + m_4x_4}{m_1 + m_2 + m_3 + m_4}$$

$$X = \frac{0 + 40x_4}{100} \Rightarrow 3 = \frac{40x_4}{100}$$

$$x_4 = \frac{300}{40} = 7.5$$

Similarly  $y_4 = 7.5$  and  $z_4 = 7.5$

186

(a)

$$\frac{1}{2}MR^2 = I \Rightarrow MR^2 = 2I$$

Moment of inertia of disc about a tangent in a plane

$$= \frac{5}{4}MR^2 = \frac{5}{4}(2I) = \frac{5}{2}I$$

187

(c)

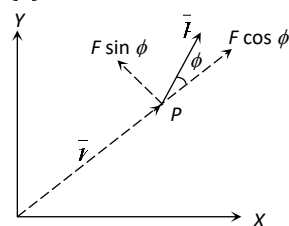

$$\vec{\tau} = \vec{r} \times \vec{F} = r F \sin \phi \therefore \tau = rF \sin \phi$$



$F \sin \phi =$  transverse component of force

$F \cos \phi =$  radial component of force

188 **(b)**

M.I. of a cylinder about its centre and parallel to its length  $= \frac{MR^2}{2}$

M.I. about its centre and perpendicular to its length  $= M \left( \frac{L^2}{12} + \frac{R^2}{4} \right)$

According to problem,  $\frac{ML^2}{12} + \frac{MR^2}{4} = \frac{MR^2}{2}$

By solving we get  $L = \sqrt{3}R$

189 **(a)**

Due to centrifugal force

190 **(a)**

Angular acceleration is a axial vector

191 **(a)**

$$v = \sqrt{\frac{2gh}{1 + \frac{K^2}{R^2}}} = \sqrt{\frac{2gh}{1 + \frac{2}{5}}} = \sqrt{\frac{10}{7}gh}$$

192 **(d)**

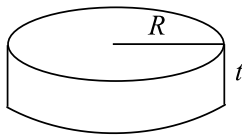

For circular disc 1

Mass =  $M$ , radius  $R_1 = R$

Moment of inertia  $I_1 = I_0$

For circular disc 2, of same thickness  $t$ , mass =  $M$

But density  $= \frac{1}{2} \times$  density of circular disc 1

Let radius =  $R_2$

Then  $\pi R_2^2 t \times \frac{\rho}{2} = \pi R_1^2 t \times \rho = M \Rightarrow R_2^2 = 2R_1^2$

$R_2 = \sqrt{2}R_1 = \sqrt{2}R$

$\therefore$  The given axis passes through the centre of mass

$\therefore$  Moment of inertia  $I \propto (\text{Radius})^2$

$$\Rightarrow \frac{I_1}{I_2} = \left( \frac{R_1}{R_2} \right)^2 \Rightarrow \frac{I_0}{I_2} = \left( \frac{R}{\sqrt{2}R} \right)^2 \Rightarrow I_2 = 2I_0$$

193 **(a)**

$L = rP \Rightarrow \log_e L = \log_e P + \log_e r$

If graph is drawn between  $\log_e L$  and  $\log_e P$  then it will be straight line which will not pass through the origin

194 **(d)**

Here  $m_1 = m_2 = m$ ,  $u_1 = u$  and  $u_2 = 0$

$$\therefore v_1 = u_1 \frac{(m_1 - em_2)}{(m_1 + m_2)} + u_2 \frac{(1 + e)m_2}{(m_1 + m_2)} = \frac{u(1 - e)}{2}$$

$$\Rightarrow \frac{v_1}{u} = \left( \frac{1 - e}{2} \right)$$

195 **(c)**

From Kepler's second law of motion, a line joining any planet to the sun sweeps out equal areas in equal intervals of time. Let any instant  $t$ , the planet is in position  $A$ . Then area swept out by  $SA$  is



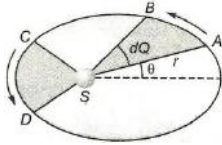

$dA = \text{area of the curved triangle } SAB$   
 $= \frac{1}{2}(AB \times SA) = \frac{1}{2}(rd\theta \times r) = \frac{1}{2}r^2d\theta$

The instantaneous areal speed is

$$\frac{dA}{dt} = \frac{1}{2}r^2 \frac{d\theta}{dt} = \frac{1}{2}r^2\omega$$

Let  $J$  be angular momentum,  $I$  the moment of inertia and  $m$  the mass, then

$$J = I\omega = mr^2\omega$$

$$\therefore \frac{dA}{dt} = \frac{J}{2m} = \text{constant}$$

Hence, angular momentum of the planet is conserved.

196

**(b)**

The  $x$  coordinate of centre of mass is

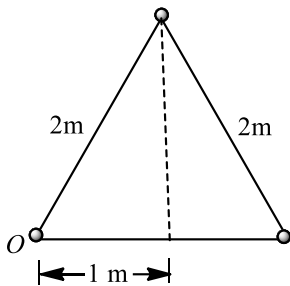

$$\bar{x} = \frac{\sum m_i x_i}{\sum m_i} = \frac{m \times 0 + m \times 1 + m \times 2}{m + m + m} = 1$$

$$\bar{y} = \frac{\sum m_i y_i}{\sum m_i} = \frac{m \times 0 + m(2 \sin 60^\circ) + m \times 0}{m + m + m}$$

$$\bar{y} = \frac{\sqrt{3}m}{3m} = \frac{1}{\sqrt{3}}$$

Position vector of centre of mass is  $(\hat{i} + \frac{1}{\sqrt{3}}\hat{j})$ .

197

**(a)**

Moment of inertia of rod about the given axis =  $\frac{ML^2}{12}$

Moment of inertia of each disc about its diameter

$$= \frac{MR^2}{4}$$

Using theorem of parallel axes, moment of inertia of each disc about the given axis

$$= \frac{MR^2}{4} + M\left(\frac{L}{2}\right)^2 = \frac{MR^2}{4} + \frac{ML^2}{4}$$

$\therefore$  For theorem of parallel axes, moment of inertia about the given axis is

$$I = \frac{mL^2}{12} + \left(\frac{MR^2}{4} + \frac{ML^2}{4}\right)$$

$$I = \frac{mL^2}{12} + \frac{MR^2}{4} + \frac{ML^2}{4}$$

198

**(b)**

Here,  $r = 4m, T = 2s, a = ?$



$$a = r\omega^2 = r\left(\frac{2\pi}{T}\right)^2 = \frac{4\pi^2 r}{T^2} = 4\pi^2 \times \frac{4}{2^2} = 4\pi^2 \text{ms}^{-2}$$

199 **(d)**

About  $EG$ , the maximum distance from the axis is the least *i. e.* distribution of mass is minimum

200 **(c)**

$$\alpha = \frac{2\pi(n_2 - n_1)}{t} = \frac{2\pi\left(0 - \frac{60}{60}\right)}{60} = \frac{-2\pi}{60} = \frac{-\pi}{30} \text{rad/sec}^2$$

$$\therefore \tau = I\alpha = \frac{2 \times \pi}{30} = \frac{\pi}{15} \text{N} - \text{m}$$

201 **(b)**

When two identical balls collide head on elastically, they exchange their velocities. Hence when  $A$  collides with  $B$ ,  $A$  transfers its whole velocity to  $B$ . When  $B$  collides with  $C$ ,  $B$  transfers its whole velocity to  $C$ . Hence finally  $A$  and  $B$  will be at rest and only  $C$  will be moving forward with speed  $v$

202 **(d)**

$$I = M\left(\frac{L^2}{12} + \frac{r^2}{4}\right) = M\left(\frac{L^2}{12} + \frac{D^2}{16}\right)$$

203 **(b)**

$$\text{Rotational kinetic energy} = \frac{1}{2}I\omega^2 = 1500$$

$$\Rightarrow \frac{1}{2} \times 1.2 \times \omega^2 = 1500$$

$$\Rightarrow \omega^2 = \frac{3000}{1.2} \Rightarrow \omega = 50 \text{ rad/s}$$

Initially the body was at rest and after  $t$  sec its angular velocity becomes  $50 \text{ rad/s}$   
 $\omega = \omega_0 + at \Rightarrow 50 = 0 + 25 \times t \Rightarrow t = 2 \text{ s}$

204 **(b)**

By doing so the distribution of mass can be made away from the axis of rotation

205 **(c)**

$$X_{\text{CM}} = \frac{m_1x_1 + m_2x_2}{m_1 + m_2}$$

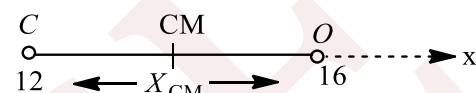

$$\therefore X_{\text{CM}} = \frac{(12 \times 0) + (16 \times 1.13)}{12 + 16} = 0.6457 \text{ \AA}$$

206 **(a)**

As initially both the particles were at rest therefore velocity of centre of mass was zero and there is no external force on the system so speed of centre of mass remains constant *i. e.* it should be equal to zero

207 **(c)**

$$\frac{K_R}{K_N} = \frac{K^2/R^2}{1 + K^2/R^2} = \frac{2/5}{1 + 2/5} = 2/7$$

208 **(d)**

Moment of inertia of cylinder about an axis through the centre and perpendicular to its axis is

$$I_c = M\left(\frac{R^2}{4} + \frac{L^2}{12}\right)$$

Using theorem of parallel axes, moment of inertia of the cylinder about an axis through its edge would be



$$I = I_c + M \left(\frac{L}{2}\right)^2 = M \left(\frac{R^2}{4} + \frac{L^2}{12} + \frac{L^2}{4}\right)$$

$$= M \left(\frac{R^2}{4} + \frac{L^2}{3}\right)$$

When  $L = 6R, I_h = \frac{49}{4}MR^2$

209 (a)

$$I = \frac{ML^2}{12} = \frac{0.12 \times 1^2}{12} = 0.01 \text{ kg} - \text{m}^2$$

210 (c)

The moment of inertia is maximum about axis 3, because rms distance of mass is maximum for this axis

211 (d)

$$v = \sqrt{\frac{2gh}{1 + \frac{k^2}{R^2}}}$$

Where  $k$  is the radius of gyration

For ring,  $\frac{k^2}{R^2} = 1$

$$\therefore v = \sqrt{\frac{2gh}{1+1}} = \sqrt{gh}$$

213 (b)

Moment of inertia of the system about the centre of plane is given by

$$I = \left[ \frac{2}{5} \times 1 \times (0.1)^2 + 1 \times (1)^2 \right] + \left[ \frac{2}{5} \times 2 \times (0.1)^2 + 2 \times (1)^2 \right]$$

$$+ \left[ \frac{2}{5} \times 3 \times (0.1)^2 + 3 \times (1)^2 \right] + \left[ \frac{2}{5} \times 4 \times (0.1)^2 + 4 \times (1)^2 \right]$$

$$= 1.004 + 2.008 + 3.012 + 4.016$$

$$= 10.04 \text{ kg} - \text{m}^2$$

214 (d)

$$\omega = \omega_0 + \alpha t \Rightarrow \omega = 0 + \left(\frac{\tau}{I}\right)t \quad [\text{As } \tau = I\alpha]$$

$$\omega = 0 + \frac{1000}{200} \times 3 = 15 \text{ rad/s}$$

215 (a)

In this question distance of centre of mass of new disc from the centre of mass of remaining disc is  $\alpha R$ .

Mass of remaining disc

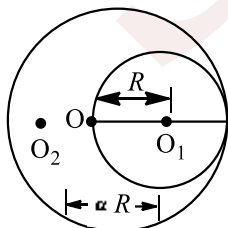

$$= M - \frac{M}{4} = \frac{3M}{4}$$

$$\therefore -\frac{3M}{4}\alpha R + \frac{M}{4}R = 0$$



$$\therefore \alpha = \frac{1}{3}$$

216 (a)

$$\frac{I_{\text{Sphere}}}{I_{\text{Cylinder}}} = \frac{\frac{2}{5}M_1R^2}{\frac{1}{2}M_2R^2} = \frac{\frac{2}{5}\left(\frac{4}{3}\pi R^3\rho\right)R^2}{\frac{1}{2}(\pi R^2L\rho)R^2} = \frac{16}{15}$$

$$\therefore I_{\text{Sphere}} > I_{\text{Cylinder}}$$

217 (d)

$$I_{\text{CD}} = I_{\text{CM}} + M\left(\frac{L}{4}\right)^2$$

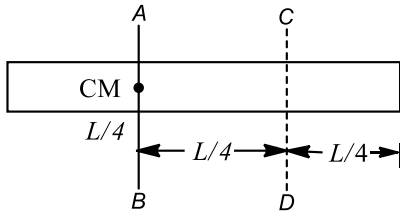

$$= \frac{ML^2}{12} + \frac{ML^2}{16} = \frac{7ML^2}{48}$$

218 (c)

$$\text{Kinetic energy } E = \frac{L^2}{2I}$$

If angular momenta are equal then  $E \propto \frac{1}{I}$

Kinetic energy  $E = K$  [Given in the problem]

If  $I_A > I_B$  then  $K_A < K_B$

220 (d)

$$\mathbf{L} = \mathbf{r} \times \mathbf{P} = \begin{vmatrix} \hat{i} & \hat{j} & \hat{k} \\ 1 & 2 & -1 \\ 3 & 4 & -2 \end{vmatrix}$$

$$\mathbf{L} = \hat{i}(-4 + 4) - \hat{j}(-2 + 3) + \hat{k}(4 - 6) = -\hat{j} - 2\hat{k}$$

$\mathbf{L}$  has components along  $-y$  axis and  $-z$  axis.

The angular momentum is in  $y - z$  plane *ie.*, perpendicular to  $x$ -axis.

221 (c)

Moment of inertia of uniform circular disc about diameter =  $I$

According to theorem of perpendicular axes,

$$\text{Moment of inertia of disc about its axis} = 2I \left( = \frac{1}{2}mr^2 \right)$$

Applying theorem of parallel axes

Moment of inertia of disc about the given axis

$$= 2I + mr^2 = 2I + 4I = 6I$$

222 (d)

Angular displacement during time

$$\begin{aligned} \theta &= (\omega_2 - \omega_1)t \\ &= (2\pi n_2 - 2\pi n_1)t \\ &= (600\pi - 200\pi) \times 10 \\ &= 4000\pi \text{ rad} \end{aligned}$$

Therefore, number of revolutions made during this time

$$= \frac{4000\pi}{2\pi} = 2000$$

223 (b)

Let rod is placed along  $x$ -axis. Mass of element  $PQ$  of length  $dx$  situated at  $x = x$  is



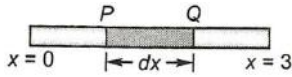

$$dm = \lambda dx = (2 + x) dx$$

The CM of the element has coordinates  $(x, 0, 0)$ .

Therefore,  $x$ -coordinates of CM of the rod will be

$$\begin{aligned} x_{CM} &= \frac{\int_0^3 x dm}{\int_0^3 dm} \\ &= \frac{\int_0^3 x(2+x) dx}{\int_0^3 (2+x) dx} \\ &= \frac{\int_0^3 (2x+x^2) dx}{\int_0^3 (2+x) dx} \\ &= \frac{\left[ \frac{2x^2}{2} + \frac{x^3}{3} \right]_0^3}{\left[ 2x + \frac{x^2}{2} \right]_0^3} \\ &= \frac{\left[ (3)^2 + \frac{(3)^3}{3} \right]}{\left[ 2 \times 3 + \frac{(3)^2}{2} \right]} = \frac{9+9}{6+9/2} \\ &= \frac{18 \times 2}{21} = \frac{12}{7} \text{m} \end{aligned}$$

224 (d)

$$I = MK^2 = 160 \Rightarrow K^2 = \frac{160}{M} = \frac{160}{10} = 16 \Rightarrow K = 4 \text{metre}$$

225 (b)

As the mass of disc is negligible therefore only moment of inertia of five particles will be considered

$$I = \sum mr^2 = 5mr^2 = 5 \times 2 \times (0.1)^2 = 0.1 \text{kg} - \text{m}^2$$

226 (b)

$\tau = I\alpha$ , if  $\tau = 0$  then  $\alpha = 0$  because moment of inertia of any body cannot be zero

227 (a)

Since, no external torque is acting the angular ( $J$ ) is conserved.

$$J = I\omega = \text{constant}$$

Where  $I (= mr^2)$  is moment of inertia and  $\omega$  the angular velocity.

$$\text{Given, } I_1 = I, I_2 = \frac{I}{n}, \omega_1 = \omega$$

$$\therefore J = I_1\omega_1 = I_2\omega_2$$

$$I\omega = \frac{I}{n}\omega_2$$

$$\Rightarrow \omega_2 = n\omega$$

Hence, angular velocity increases by a factor of  $n$ .

228 (c)

$$\text{Loss of kinetic energy} = \frac{1}{2} \frac{m_1 m_2}{m_1 + m_2} (v_1 - v_2)^2$$

$$= \frac{1}{2} \frac{M \times M}{(M + M)} (v_1 - v_2)^2$$

$$= \frac{M \cdot M}{2(2M)} (v_1 - v_2)^2$$

$$= \frac{M}{4} (v_1 - v_2)^2$$

229 (b)

Angular moment of particle w.r.t., origin



=linear momentum  $\times$  perpendicular distance of line of action of linear momentum from origin

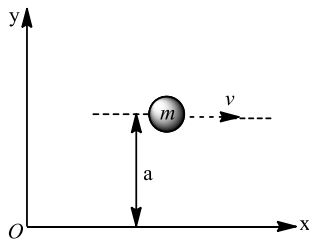

$$= mv \times a = mva = \text{constant}$$

230 (a)

He decreases his Moment of inertia by this act and therefore increases his angular velocity

231 (c)

Let  $T$  be the tension in the string carrying

The masses  $m$  and  $3m$

Let  $a$  be the acceleration, then

$$T - mg = ma \quad \dots(i)$$

$$3mg - T = 3ma \quad \dots(ii)$$

Adding Eqs. (i) and (ii), we get

$$2mg + 4ma$$

$$\Rightarrow a = \frac{g}{2}$$

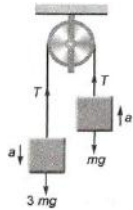

232 (c)

Let same mass and same outer radii of solid sphere and hollow sphere are  $M$  and  $R$  respectively. The moment of inertia of solid sphere  $A$  about its diameter

$$I_A = \frac{2}{5}MR^2 \quad \dots(i)$$

Similarly, the moment of inertia of hollow sphere (spherical shell)  $B$  about its diameter

$$I_B = \frac{2}{3}MR^2 \quad \dots(ii)$$

It is clear from Eqs. (i) and (ii), we get

$$I_A < I_B$$

233 (a)

By the conservation of energy

$P.E.$  of rod = Rotational  $K.E.$

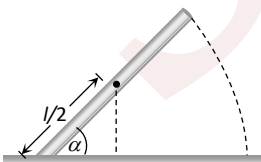

$$mg \frac{l}{2} \sin \alpha = \frac{1}{2} I \omega^2 \Rightarrow mg \frac{l}{2} \sin \alpha = \frac{1}{2} \frac{ml^2}{3} \omega^2$$

$$\Rightarrow \omega = \sqrt{\frac{3g \sin \alpha}{l}}$$

But in the problem length of the rod  $2L$  is given



$$\Rightarrow \omega = \sqrt{\frac{3g \sin \alpha}{2L}}$$

234

(c)

Time taken in reaching bottom of incline is

$$t = \sqrt{\frac{2l(1 + K^2/R^2)}{g \sin \theta}}$$

For solid cylinder (SC),  $K^2 = R^2/2$

For hollow cylinder (HC),  $K^2 = R^2$

For solid sphere (S),  $K^2 = \frac{2}{5}R^2$

235

(b)

According to figure let A is the origin and co-ordinates of centre of mass be (x, y) then,

$$x = \frac{m_1x_1 + m_2x_2 + m_3x_3 + m_4x_4}{m_1 + m_2 + m_3 + m_4}$$

$$= \frac{0 + 2 \times \frac{80}{\sqrt{2}} + 4 \times \frac{80}{\sqrt{2}} + 0}{16} = \frac{30}{\sqrt{2}}$$

Similarly  $y = \frac{30}{\sqrt{2}}$  so,  $r = \sqrt{x^2 + y^2} = 30\text{cm}$

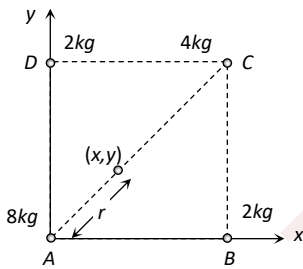

236

(b)

$$I = MK^2 = \sum mR^2$$

where  $M$  is the total mass of the body.

This means that

$$K = \sqrt{\left(\frac{I}{M}\right)}$$

According to thermo of parallel axis

$$I = I_{CG} + M(2R)^2$$

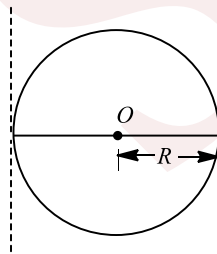

where,  $I_{CG}$  is moment of inertia about an axis through centre of gravity.

$$\therefore I = \frac{2}{5}MR^2 + 4MR^2 = \frac{22}{5}MR^2$$

$$\text{or } MK^2 = \frac{22}{5}MR^2$$

$$\therefore K = \sqrt{\frac{22}{5}}R$$



237

(a)

The situation can be shown as: Let radius of complete disc is  $a$  and that of small disc is  $b$ , also let centre of mass now shifts to  $O_2$  at a distance  $x_2$  from original centre

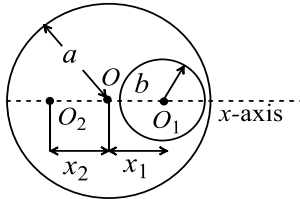

The position of new centre of mass is given by

$$X_{CM} = \frac{-\sigma \pi b^2 \cdot x_1}{\sigma \pi a^2 - \sigma \cdot \pi b^2}$$

Here,  $a = 6\text{cm}$ ,  $b = 2\text{cm}$   $x_1 = 3.2\text{cm}$

$$\begin{aligned} \text{Hence, } X_{CM} &= \frac{-\sigma \times \pi (2)^2 \times 3.2}{\sigma \times \pi \times (6)^2 - \sigma \times \pi \times (2)^2} \\ &= \frac{12.8\pi}{32\pi} = -0.4\text{cm} \end{aligned}$$

238

(b)

$$v = \sqrt{\frac{2gh}{1 + \frac{K^2}{R^2}}} = \sqrt{\frac{2gh}{1 + \frac{1}{2}}} = \sqrt{\frac{4}{3}gh}$$

240

(c)

$$I = \frac{2}{5}MR^2 = \frac{2}{5}\left(\frac{4}{3}\pi R^3\rho\right)R^2 = \frac{8}{15} \times \frac{22}{7}R^5\rho$$

$$I = \frac{176}{105}R^5\rho$$

241

(b)

Here, Moment of inertia,  $I = 3 \times 10^2 \text{kg m}^2$

Torque,  $\tau = 6.9 \times 10^2 \text{Nm}$

Initial angular speed,  $\omega_0 = 4.6 \text{rad s}^{-1}$

Final angular speed,  $\omega = 0 \text{rad s}^{-1}$

As  $\omega = \omega_0 + \alpha t$

$$\alpha = \frac{\omega - \omega_0}{t} = \frac{0 - 4.6}{t} = -\frac{4.6}{t} \text{rad s}^{-2}$$

Negative sign is for deceleration Torque,  $\tau = I\alpha$

$$6.9 \times 10^2 = 3 \times 10^2 \times \frac{4.6}{t}$$

$$t = \frac{3 \times 10^2 \times 4.6}{6.9 \times 10^2} = 2\text{s}$$

242

(d)

Here, mass of the disc,  $M = 1 \text{kg}$

Radius of the disc,  $R = 2\text{m}$

Moment of inertia of the circular disc about  $XY$  is

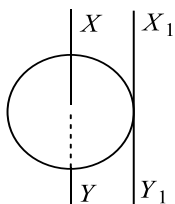

$$I_{XY} = \frac{MR^2}{2} = 2kg m^2 \text{ [Given]}$$

According to theorem of parallel axes the moment of inertia of the circular disc about  $X_1Y_1$  is

$$\begin{aligned} I_{X_1Y_1} &= I_{XY} + MR^2 = \frac{MR^2}{2} + MR^2 \\ &= \frac{3}{2}MR^2 = \frac{3}{2} \times (1kg) \times (2m)^2 = 6kgm^2 \end{aligned}$$

- 243 **(b)** According to the theorem of || axes, Moment of inertia of disc about an axis passing through  $K$  and  $\perp$  to plane of disc,

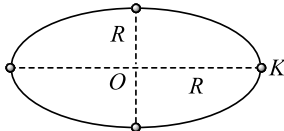

$$= \frac{1}{2}MR^2 + MR^2 = \frac{3}{2}MR^2$$

Total moment of inertia of the system

$$\begin{aligned} &= \frac{3}{2}MR^2 + m(2R)^2 + m(\sqrt{2}R)^2 + m(\sqrt{2}R)^2 \\ &= 3(M + 16m) \frac{R^2}{12} \end{aligned}$$

- 244 **(a)**  $\frac{1}{2}mv^2 \left(1 + \frac{K^2}{R^2}\right) = \frac{1}{2}(0.5)(0.2)^2 \left(1 + \frac{2}{5}\right) = 0.014 J$

- 245 **(b)**  $\frac{ma^2}{12} + m(4a^2) = \frac{ma^2}{6} + md^2$   
or  $d^2 = \frac{47a^2}{12}$   
 $\therefore d = \sqrt{\frac{47}{12}} a$

- 246 **(a)** The resultant force on the system is zero. So, the centre of mass of system has no acceleration

- 247 **(b)** According to law of conservation of momentum  
 $I\omega = \text{constant}$

When viscous fluid of mass  $m$  is dropped and start spreading out then its moment of inertia increases and angular velocity decreases. But when it falls from the platform moment of inertia decreases so angular velocity increases again

- 248 **(d)** For disc,  $I = \frac{1}{2}ma^2$   
For ring,  $I = ma^2$   
For square of side  $2a = \frac{M}{12} [(2a)^2 + (2a)^2] = \frac{2}{3}Ma^2$

For square of rod of length  $2a$

$$I = 4 \left[ M \frac{(2a)^2}{12} + Ma^2 \right] = \frac{16}{3}Ma^2$$

Hence, moment of inertia is maximum for square of four rods

- 249 **(b)**



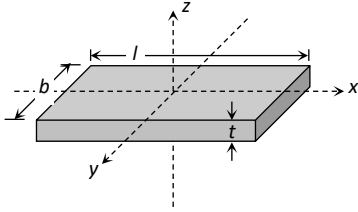

M.I. of block about x axis,  $I_x = \frac{m}{12}(b^2 + t^2)$

M.I. of block about y axis,  $I_y = \frac{m}{12}(l^2 + t^2)$

M.I. of block about z axis,  $I_z = \frac{m}{12}(l^2 + b^2)$

As  $l > b > t \therefore I_z > I_y > I_x$

250 (a)

Mass of a rod,  $m = 1.8\text{kg}$

$\therefore$  Weight of a rod,  $W = mg = 1.8\text{kg} \times 10\text{ms}^{-2} = 18\text{N}$

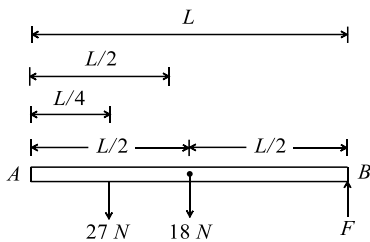

As the rod is uniform, therefore weight of the rod is acting at its midpoint

Taking moments about A,

$$27 \times \frac{L}{4} + 18 \times \frac{L}{2} = F \times L$$

$$\Rightarrow FL = \frac{L}{4}[27 + 36] = \frac{63L}{4} \Rightarrow F = \frac{63}{4} = 16\text{N}$$

251 (b)

Given : kinetic energy  $K = 360\text{J}$

Angular speed  $\omega = 20\text{ rad/s}$

$$\therefore K = \frac{1}{2}I\omega^2$$

Where  $I =$  moment of inertia

$$\Rightarrow I = \frac{2K}{\omega^2} = \frac{2 \times 360}{20 \times 20} = 1.8\text{A kg m}^{-2}$$

252 (a)

$$\tau = \frac{dL}{dt} = \frac{L_2 - L_1}{\Delta t} = \frac{5L - 2L}{3} = \frac{3L}{3} = L$$

254 (a)

By the theorem of perpendicular axes, the moment of inertia about the central axis  $I_C$ , will be equal to the sum of its moments of inertia about two mutually perpendicular diameters lying in its plane.

Thus,  $I_d = I = \frac{1}{2}MR^2$

$$\begin{aligned} \therefore I_C &= I + I \\ &= \frac{1}{2}MR^2 + \frac{1}{2}MR^2 \\ &= I + I = 2I \end{aligned}$$

256 (d)

$L = \sqrt{2IE}$ . If  $E$  are equal then  $\frac{L_1}{L_2} = \sqrt{\frac{I_1}{I_2}} = \sqrt{\frac{I}{2I}} = \frac{1}{\sqrt{2}}$



257

(c)

Frequency of wheel,  $v = \frac{300}{60} = 5$  rps. Angle described by wheel in one rotation =  $2\pi$  rad

Therefore, angle described by wheel in 1s

$$= 2\pi \times 5 \text{ rad}$$

$$= 10\pi \text{ rad.}$$

258

(a)

(1) Angular velocity of earth

$$\begin{aligned}\omega_1 &= \frac{2\pi}{T} = \frac{2\pi}{24 \times 60 \times 60} \\ &= \frac{2\pi}{86400} \text{ rads}^{-1}\end{aligned}$$

(2) Angular velocity of hour's hand of a clock

$$\begin{aligned}\omega_2 &= \frac{2\pi}{T} \\ &= \frac{2\pi}{12 \times 60 \times 60} \\ &= \frac{2\pi}{43200} \text{ rads}^{-1}\end{aligned}$$

(3) Angular velocity of seconds hand of a clock

$$\begin{aligned}\omega_3 &= \frac{2\pi}{T} \\ &= \frac{2\pi}{1 \times 60} = \frac{2\pi}{60} \text{ rads}^{-1}\end{aligned}$$

(4) Angular velocity of flywheel

$$\begin{aligned}\omega_4 &= 2\pi n \\ &= 2\pi \times \frac{300}{60} \\ &= 2\pi \times 5 \text{ rads}^{-1}\end{aligned}$$

259

(b)

Let ball strikes at a speed  $u$  the  $K_1 = \frac{1}{2}mu^2$

Due to collision tangential component of velocity remains unchanged at  $u \sin 45^\circ$ , but the normal component of velocity change to  $u \sin 45^\circ = \frac{1}{2}u \cos 45^\circ$

$\therefore$  Final velocity of ball after collision

$$\begin{aligned}v &= \sqrt{(u \sin 45^\circ)^2 + \left(\frac{1}{2}u \cos 45^\circ\right)^2} \\ &= \sqrt{\left(\frac{u}{\sqrt{2}}\right)^2 + \left(\frac{u}{2\sqrt{2}}\right)^2} = \sqrt{\frac{5}{3}}u.\end{aligned}$$

Hence final kinetic energy  $K_2 = \frac{1}{2}mv^2 = \frac{5}{16}mu^2$ .

$\therefore$  Fractional loss in KE

$$= \frac{K_1 - K_2}{K_1} = \frac{\frac{1}{2}mu^2 - \frac{5}{16}mu^2}{\frac{1}{2}mu^2} = \frac{3}{8}$$

260

(a)

Clearly, the question refers to the torque about an axis through the centre of wheel. Then, since the radius to the point application of the force is the lever or momentum arm.



we have

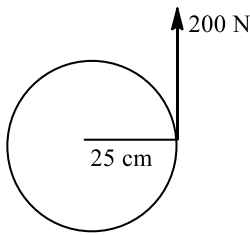

$$\tau = 0.25 \times 200 = 50 \text{ Nm}$$

261 (d)

$$I = \frac{2}{5}MR^2 \therefore I \propto R^2$$

This relation shows that graph between  $I$  and  $R$  will be parabola symmetric to  $I$ -axis

263 (a)

$$\frac{2}{5}MR^2 = \frac{1}{2}Mr^2 + Mr^2$$

$$\text{or } \frac{2}{5}MR^2 = \frac{3}{2}Mr^2$$

$$\therefore r = \frac{2}{\sqrt{15}}R$$

264 (b)

$$\frac{I_{Ring}}{I_{Disc}} = \frac{MR^2}{1/2MR^2} = 2:1$$

265 (b)

According to the theorem of perpendicular axes.

$$I_{AB} + I_{CD} = MR^2$$

$$I_d + I_d = I$$

$$(\because I_{AB} = I_{CD} = I_d)$$

$$2I_d = I$$

$$I_d = \frac{I}{2}$$

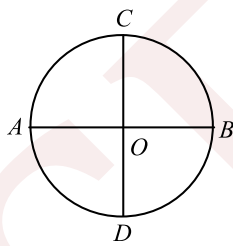

where,  $I_d$  = moment of inertia about diameter of the ring,  $I$  = moment of inertia about axes passing through to the ring.

266 (b)

(I) Moment of inertia of a cylinder about its centre and parallel to its length =  $\frac{MR^2}{2}$

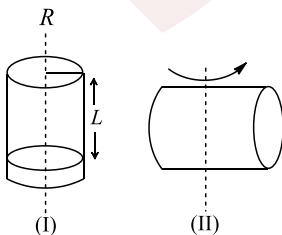

(II) Moment of inertia about its centre and perpendicular to its length =  $M \left( \frac{L^2}{12} + \frac{R^2}{4} \right)$



$$\frac{ML^2}{12} + \frac{MR^2}{4} = \frac{MR^2}{2}$$

$$\text{Or } L = \sqrt{3}R$$

267

(b)

Let at the time explosion velocity of one piece of mass  $m/2$  is  $(10\hat{i})$ . If velocity of other be  $\vec{v}_2$ , then from conservation law of momentum (since there is no force in horizontal direction), horizontal component of  $\vec{v}_2$ , must be  $-10\hat{i}$ .

$\therefore$  Relative velocity of two parts in horizontal direction =  $20\text{ms}^{-1}$

Time taken by ball to fall through 45m,

$$= 20 = \sqrt{\frac{2h}{g}} = \sqrt{\frac{2 \times 45}{10}} = 3\text{s} \text{ and time taken by ball to fall through first 20m, } t' = \sqrt{\frac{2h'}{g}} = \sqrt{\frac{2 \times 20}{10}} = 2\text{s.}$$

Hence time taken by ball pieces to fall from 25 m height to ground =  $t - t' = 3 - 2 = 1\text{s}$ .

$\therefore$  Horizontal distance between the two pieces at the time of striking on ground =  $20 \times 1 = 20\text{m}$

269

(c)

Graph should be parabola symmetric to  $I$ -axis, but it should not pass from origin because there is a constant value  $I_{cm}$  is present for  $x = 0$

270

(d)

Weight of the rod will produce the torque

$$\tau = I\alpha \Rightarrow mg \times \frac{l}{2} = \frac{ml^2}{3} \times \alpha$$

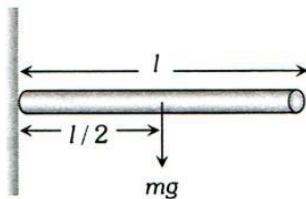

Angular acceleration

$$\alpha = \frac{3g}{2l}$$

271

(a)

The situation can be shown as

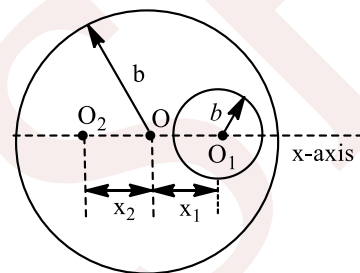

Let radius of complete disc is  $a$  and that of small disc is  $b$ . Also let centre of mass now shifts to  $O_2$  at a distance  $x_2$  from original centre.

The position of new centre of mass is given by

$$X_{CM} = \frac{-\sigma\pi b^2 x_1}{\sigma\pi a^2 - \sigma\pi b^2}$$

Here,  $a = 6\text{ cm}$ ,  $b = 2\text{ cm}$ ,  $x_1 = 3.2\text{ cm}$

$$\begin{aligned} \text{Hence, } X_{CM} &= \frac{-\sigma \times \pi (2)^2 \times 3.2}{\sigma \times \pi \times (6)^2 - \sigma \times \pi \times (2)^2} \\ &= -\frac{12.8\pi}{32\pi} = -0.4\text{ cm} \end{aligned}$$



272 **(a)**  
Initial acceleration of the system is zero. So it will always remain zero because there is no external force on the system

273 **(d)**  
Rotational kinetic energy  $= \frac{1}{2} I \omega^2 = \frac{1}{2} \left( \frac{1}{2} M R^2 \right) \times \omega^2$   
 $= \frac{1}{2} \left( \frac{1}{2} \times 10 \times (0.5)^2 \right) \times (20)^2 = 250 \text{ J}$

274 **(d)**  
 $\frac{1}{2} I \omega^2 = \frac{1}{2} m v^2 \Rightarrow \frac{1}{2} \times 3 \times (2)^2 = \frac{1}{2} \times 12 \times v^2$   
 $\Rightarrow v = 1 \text{ m/s}$

275 **(b)**  
In doing so moment of inertia is decreased and hence angular velocity is increased

276 **(b)**  
In the absence external force, position of centre of mass remain same therefore they will meet at their centre of mass

277 **(a)**  
Moment of inertia of rod  $AB$  about point  $P$  and perpendicular to the plane  $= \frac{Ml^2}{12}$

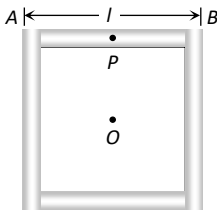

$$\text{M.I. of rod } AB \text{ about point 'O'} = \frac{Ml^2}{12} + M \left( \frac{l}{2} \right)^2 = \frac{Ml^2}{3}$$

(By using parallel axis theorem)

But the system consists of four rods of similar type so by but the symmetry  $I_{\text{System}} = 4 \left( \frac{Ml^2}{3} \right)$

278 **(c)**  
 $x_{CM} = \frac{\sum m_i x_i}{\sum m_i}$ , Refer to figure

$$= \frac{M \times 0 + M \times 1 + M \times 2}{M + M + M} = 1$$

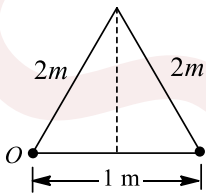

$$y_{CM} = \frac{\sum m_i y_i}{\sum m_i}$$

$$= \frac{M \times 0 + M(2 \sin 60^\circ) + M \times 0}{M + M + M}$$

$$= \frac{\sqrt{3}M}{3M} = \frac{1}{\sqrt{3}}$$

$\therefore$  Position vector of centre of mass is  $\left( \hat{i} + \frac{1}{\sqrt{3}} \hat{j} \right)$

279 **(a)**  
Angular velocity  $= \omega$



Centripetal force  $F = mr\omega^2$

or  $r \propto \frac{1}{\omega^2}$

$\therefore \frac{r_1}{r_2} = \frac{\omega_2^2}{\omega_1^2}$

or  $\frac{4}{r_2} = \frac{4\omega^2}{\omega^2}$

or  $r_2 = 1 \text{ cm}$

280 **(b)**

Time of descent will be less for solid sphere *i. e.* solid sphere will reach first at the bottom of inclined plane

281 **(d)**

Let  $a$  be acceleration of fall of the thread, then net force acting downwards, balances the force due to tension ( $T$ ) in the thread.

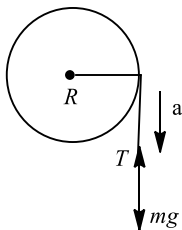

$$mg - T = ma$$

$$\Rightarrow mg - ma = T \quad \dots(i)$$

Also torque (also known as moment or couple acts on the system).

$\tau = \text{force} \times \text{perpendicular distance axis of rotation}$

$$\tau = T \times R$$

From Eq. (i),

$$\tau = m(g - a) \times R \quad \dots(ii)$$

Let  $I$  is moment of inertia of reel and  $\alpha$  the angular acceleration, then torque is

$$\tau = I\alpha \quad \dots(iii)$$

where,  $I = \frac{1}{2}MR^2$ ,  $\alpha = \frac{a}{R}$

$$\therefore \tau = \frac{1}{2}MR^2 \times \frac{a}{R} = \frac{MRa}{2} \quad \dots(iv)$$

Equating Eqs. (ii) and (iv), we get

$$\tau = m(g - a)R = \frac{mRa}{2}$$

$$\Rightarrow g - a = \frac{a}{2}$$

$$\Rightarrow a = \frac{2}{3}g$$

282 **(c)**

Force of attraction between two stars

$$F = \frac{Gm_1m_2}{(r_1 + r_2)^2}$$

$$\text{Acceleration} = \frac{F}{m_1} = \frac{Gm_2}{(r_1 + r_2)^2}$$

283 **(c)**

Here,  $m_1 = m_2 = 0.1 \text{ kg}$

$r_1 = r_2 = 10 \text{ cm} = 0.1 \text{ m}$

$$I = I_1 + I_2 = m_1r_1^2 + \frac{1}{2}m_2r_2^2 = \frac{3}{2}m_1r_1^2$$



$$= \frac{3}{2} \times 0.1(0.1)^2 = 1.5 \times 10^{-3} \text{ kg m}^2$$

284 **(a)**

For solid sphere,  $\frac{K^2}{R^2} = \frac{2}{5}$

For disc and solid cylinder,  $\frac{K^2}{R^2} = \frac{1}{2}$

As  $\frac{K^2}{R^2}$  for solid sphere is smallest, it takes minimum time to reach the bottom of the incline

285 **(a)**

$$I = \frac{1}{2}MR^2 = \frac{1}{2} \times (\pi R^2 t \times \rho) \times R^2$$

$$\Rightarrow I \propto R^4 \quad (\text{As } t \text{ and } \rho \text{ are same})$$

$$\therefore \frac{I_1}{I_2} = \left(\frac{R_1}{R_2}\right)^4 = \left(\frac{0.2}{0.6}\right)^4 = \frac{1}{81}$$

286 **(c)**

$$m_1 r_1 = m_2 r_2$$

$$\frac{r_1}{r_2} = \frac{m_2}{m_1} \quad \therefore r \propto \frac{1}{m}$$

287 **(d)**

According to law of conservation of angular momentum, if there is no torque on the system, then the angular momentum remains constant.

288 **(b)**

Let the mass of an element of length  $dx$  of rod located at a distance  $x$  away from left end is  $\frac{M}{L} dx$ . The  $x$ -coordinate of the centre of mass is given by

$$X_{CM} = \frac{1}{M} \int x dm$$

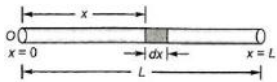

$$= \frac{1}{M} \int_0^L x \left(\frac{M}{L} dx\right)$$

$$= \frac{1}{L} \left[\frac{x^2}{2}\right]_0^L = \frac{L}{2}$$

289 **(c)**

As  $\vec{F}_{ext} = 0$ , hence momentum remains conserved and final momentum = initial momentum =  $mv$

290 **(a)**

The moment of inertia of this annular disc about the axis perpendicular to its plane will be  $\frac{1}{2}M(R^2 + r^2)$ .

291 **(b)**

Since, rod is bent at the middle, so each part of it will have same length  $\left(\frac{L}{2}\right)$  and mass  $\left(\frac{M}{2}\right)$  as shown.

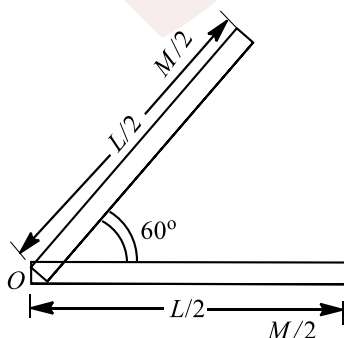

Moment of inertia of each part through its one end

$$= \frac{1}{3} \left( \frac{M}{2} \right) \left( \frac{L}{2} \right)^2$$

Hence, net moment of inertia through its middle point  $O$  is

$$I = \frac{1}{3} \left( \frac{M}{2} \right) \left( \frac{L}{2} \right)^2 + \frac{1}{3} \left( \frac{M}{2} \right) \left( \frac{L}{2} \right)^2 \\ = \frac{1}{3} \left[ \frac{ML^2}{8} + \frac{ML^2}{8} \right] = \frac{ML^2}{12}$$

292 (c)

$$K = \frac{L^2}{2I} = \frac{K_1}{K_2} = \frac{L_1^2}{L_2^2} \Rightarrow \frac{K_1}{K_2} = \left( \frac{100}{110} \right)^2 = \frac{100}{121}$$

$$\Rightarrow \frac{100}{K^2} = \frac{100}{121} \Rightarrow K_2 = 121 = 100 + 21$$

Increase in kinetic energy = 21%

293 (c)

$$I_{\text{Sphere}} < I_{\text{Disc}} < I_{\text{Shell}} < I_{\text{Ring}}$$

We know that body possessing minimum moment of inertia will reach the bottom first and the body possessing maximum moment of inertia will reach the bottom at last

294 (a)

Let a plane be inclined at an angle  $\theta$  and a cylinder rolls down then the acceleration of the cylinder of mass  $m$ , radius  $R$ , and  $I$

$I$  as moment of inertia is given by

$$a = \frac{g \sin \theta}{\left( 1 + \frac{I}{mR^2} \right)}$$

Moment of inertia ( $I$ ) of a cylinder =  $\frac{mR^2}{2}$

$$\therefore a = \frac{g \sin \theta}{\left( 1 + \frac{\frac{mR^2}{2}}{mR^2} \right)} = \frac{2}{3} g \sin 30^\circ$$

$$\Rightarrow a = \frac{g}{3}$$

295 (a)

The rotational kinetic energy of the disc is

$$K_{\text{rot}} = \frac{1}{2} I \omega^2 = \frac{1}{2} \left( \frac{1}{2} MR^2 \right) \omega^2 = \frac{1}{4} MR^2 \omega^2$$

The translational kinetic energy is

$$K_{\text{trans}} = \frac{1}{2} M v_{\text{CM}}^2$$

where  $v_{\text{CM}}$  is the linear velocity of its centre of mass.

Now,  $v_{\text{CM}} = R\omega$

Therefore,  $K_{\text{trans}} = \frac{1}{2} MR^2 \omega^2$

Thus,  $K_{\text{total}} = \frac{1}{4} MR^2 \omega^2 + \frac{1}{2} MR^2 \omega^2 = \frac{3}{4} MR^2 \omega^2$

$$\therefore \frac{K_{\text{rot}}}{K_{\text{total}}} = \frac{\frac{1}{4} MR^2 \omega^2}{\frac{3}{4} MR^2 \omega^2} = \frac{1}{3}$$

296 (c)

$$L = I\omega$$

297 (c)

Since force is not acting on centre of mass, it will produced torque hence linear and angular acceleration both will change

298 (a)



$$mgh = \frac{1}{2}I\omega^2 + \frac{1}{2}mv^2$$

$$= \frac{1}{2}\left(\frac{2}{5}mr^2\right)\omega^2 + \frac{1}{2}mv^2 = \frac{7}{10}mv^2$$

$$\therefore v = \sqrt{\frac{10}{7}gh}$$

299

(c)

For the rolling a solid cylinder acceleration  $a = \frac{g}{3} \sin \theta$

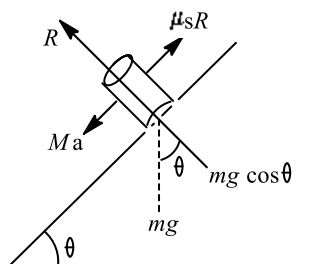

$\therefore$  The condition for the cylinder to remain in equilibrium

$$Ma \leq \mu_s R$$

$$\Rightarrow \frac{1}{2}Mg \sin \theta \leq Mg \cos \theta \cdot \mu_s$$

$$\text{or } \mu_s \geq \frac{1}{3} \tan \theta$$

$$\text{or } \tan \theta \leq 3 \mu_s$$

300

(d)

Since, no external force is present on the system so, conservation principle of momentum is applicable

$$\therefore \vec{p}_i = \vec{p}_f = \vec{p}_1 + \vec{p}_2$$

$$\therefore \vec{p}_1 = -\vec{p}_2 \quad (\because \vec{p}_i = 0)$$

$$\therefore |\vec{p}_1| = |-\vec{p}_2|$$

$$\therefore \vec{p}_1 = \vec{p}_2$$

From this point of view, it is clear that momenta of both particles are equal in magnitude but opposite in direction

Also, friction is absent. So total mechanical energy of system remains conserved

301

(d)

The angular momentum is measure for the amount of torque that has been applied over time the object. For a particle with a fixed mass that is rotating about a fixed symmetry axis, the angular momentum is expressed as

$$L = I\omega \quad \dots(i)$$

Where  $I$  is moment of inertia of particle and  $\omega$  the angular velocity.

$$\text{Also, } K = \frac{1}{2}I\omega^2 \quad \dots(ii)$$

Where  $K$  is kinetic energy of rotation.

From Eqs. (i) and (ii), we get

$$L = \frac{2K}{\omega^2} \omega = \frac{2K}{\omega}$$

$$L' = \frac{2(K/2)}{2\omega} = \frac{1}{4} \left( \frac{2K}{\omega} \right) = \frac{L}{4}$$

**Note** In a closed system angular momentum is constant.

302

(c)



As there is no external torque, angular momentum will remain constant. When the tortoise moves from  $A$  to  $C$ , figure, moment of inertia of the platform and tortoise decreases. Therefore, angular velocity of the system increases. When the tortoise moves from  $C$  to  $B$ , moment of inertia increases. Therefore, angular velocity decreases

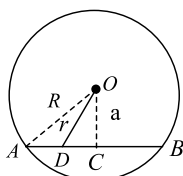

If,  $M$  = mass of platform

$R$  = radius of platform

$m$  = mass of tortoise moving along the chord  $AB$

$a$  = perpendicular distance of  $O$  from  $AB$

Initial angular momentum,  $I_1 = mR^2 + \frac{MR^2}{2}$

At any time  $t$ , let the tortoise reach  $D$  moving with velocity  $v$

$$\therefore AD = vt$$

$$AC = \sqrt{R^2 - a^2}$$

$$\text{As } DC = AC - AD = (\sqrt{R^2 - a^2} - vt)$$

$$\therefore OD = r = a^2 + [\sqrt{R^2 - a^2} - vt]^2$$

Angular momentum at time  $t$

$$I_2 = mr^2 + \frac{MR^2}{2}$$

As angular momentum is conserved

$$\therefore I_1\omega_0 = I_2\omega(t)$$

This shows that variation of  $\omega(t)$  with time is nonlinear. Choice (c) is correct

303

(a)

$$x_{CM} = \frac{m_1x_1 + m_2x_2 + \dots}{m_1 + m_2 + \dots}$$

$$= \frac{ml + 2m \cdot 2l + 3m \cdot 3l + \dots}{m + 2m + 3m + \dots}$$

$$= \frac{ml(1 + 4 + 9 + \dots)}{m(1 + 2 + 3 + \dots)} = \frac{\frac{l n(n+1)(2n+1)}{6}}{\frac{n(n+1)}{2}} = \frac{l(2n+1)}{3}$$

304

(a)

In the absence of external torque angular momentum remains constant

305

(b)

When  $l$  is length of rod and its mass, then the moment of inertia of its axis passing through its centre of gravity and perpendicular to its length is given by



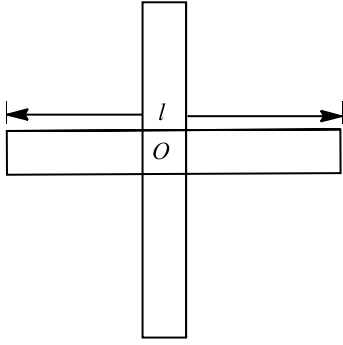

$$I = \frac{ml^2}{12}$$

For two rods as shown,

$$I = \frac{ml^2}{12} + \frac{ml^2}{12} = \frac{ml^2}{6}$$

306 **(d)**

Torque is a measure of how much a force acting on an object causes that object to rotate. The object rotates about an axis ( $O$ ). The distance from  $O$  is  $r$ , where forces acts, hence torque  $\tau = \mathbf{F} \times \mathbf{r}$ . It is a vector quantity and points from axis of rotation to the point where the force acts.

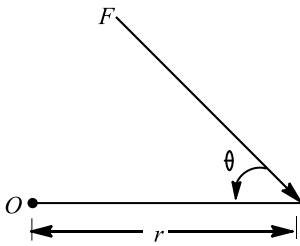

307 **(a)**

As the mass is concentrated at the centre of the rod, therefore,

$$mg \times \frac{l}{2} = \frac{1}{2} I \omega^2 = \frac{1}{2} \left( \frac{ml^2}{3} \right) \omega^2$$

$$\text{or } l^2 \omega^2 = 3gl$$

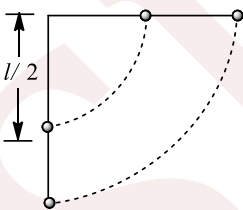

Velocity of other end of the rod

$$v = l\omega = \sqrt{3gl}$$

308 **(d)**

$$v = \sqrt{\frac{2gh}{1 + \frac{I}{mr^2}}} = \sqrt{\frac{2 \times 10 \times 3}{1 + \frac{mr^2}{2 \times mr^2}}} = \sqrt{\frac{2 \times 10 \times 3}{\frac{3}{2}}} = \sqrt{40}$$

$$\Rightarrow v = r\omega$$

$$\Rightarrow r = \frac{v}{\omega} = \frac{\sqrt{40}}{2\sqrt{2}} = \sqrt{\frac{40}{8}} = \sqrt{5} \text{ m}$$

309 **(a)**



When non-conservative force acts on a body, then mechanical energy is converted into non-mechanical energy and *vice – versa*.

310 (a)

Work done = Change in rotational kinetic energy

$$\begin{aligned} &= \frac{1}{2} I \times (\omega_1^2 - \omega_2^2) = \frac{1}{2} I \times 4\pi^2 (n_1^2 - n_2^2) \\ &= \frac{1}{2} \times \frac{9.8}{\pi^2} \times 4\pi^2 (10^2 - 5^2) = 9.8 \times 2 \times 75 = 1470 \text{ J} \end{aligned}$$

311 (b)

Co-ordinate of CM is given by

$$X_{\text{CM}} = \frac{m_1 x_1 + m_2 x_2}{m_1 + m_2}$$

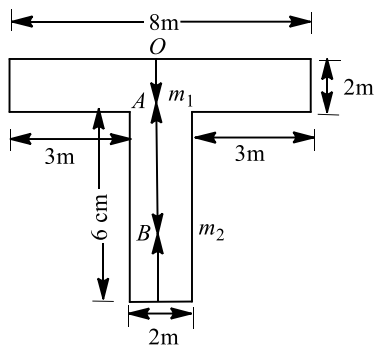

Taking parts A and B as two bodies of same system

$$m_1 = l \times b \times \sigma = 8 \times 2 \times \sigma = 16\sigma$$

$$m_2 = l \times b \times \sigma = 6 \times 2 \times \sigma = 12\sigma$$

Choosing O as origin,

$$x_1 = 1 \text{ m}, x_2 = 2 + 3 = 5 \text{ m}$$

$$\begin{aligned} \therefore X_{\text{CM}} &= \frac{16\sigma \times 1 + 12\sigma \times 5}{16\sigma + 12\sigma} = \frac{19}{7} \\ &= 2.7 \text{ m from } O \end{aligned}$$

312 (b)

Moment of inertia of a circular ring about a diameter

$$I = \frac{1}{2} Mr^2$$

313 (b)

The kinetic energy of a rolling body is

$$\frac{1}{2} mv^2 \left( 1 + \frac{k^2}{R^2} \right)$$

According to law of conservation of energy, we get

$$\frac{1}{2} mv^2 \left( 1 + \frac{k^2}{R^2} \right) = mgh$$

Where  $h$  is the height of the inclined plane

$$\therefore v = \sqrt{\frac{2gh}{1 + \frac{k^2}{R^2}}}$$

For a solid sphere  $\frac{k^2}{R^2} = \frac{2}{5}$

Substituting the given values, we get



$$v = \sqrt{\frac{2 \times 10 \times 7}{\left(1 + \frac{2}{5}\right)}} = \sqrt{\frac{2 \times 10 \times 7 \times 5}{7}} = 10 \text{ ms}^{-1}$$

314 (d)

$$\text{M.I. of disc } I = \frac{1}{2}MR^2 = \frac{1}{2}M\left(\frac{M}{\pi\rho t}\right) = \frac{1}{2}\frac{M^2}{\pi\rho t}$$

$$\left(\text{As } \rho = \frac{\text{Mass}}{\text{Volume}} = \frac{M}{\pi R^2 t} \text{ therefore } R^2 = \frac{M}{\pi\rho t}\right)$$

$$\therefore I \propto \frac{1}{\rho} \text{ [If } M \text{ and } t \text{ are constant)} \Rightarrow \frac{I_1}{I_2} = \frac{\rho_2}{\rho_1}$$

315 (c)

$$\frac{1}{2}I\omega^2 = 360 \Rightarrow I = \frac{2 \times 360}{(30)^2} = \frac{2 \times 360}{30 \times 30} = 0.8 \text{ kg} \times \text{m}^2$$

316 (d)

(a) Impulsive received by  $m$

$$\vec{J} = m(\vec{v}_f - \vec{v}_i)$$

$$= m(-2\hat{i} + \hat{j} - 3\hat{i} - 2\hat{j})$$

$$= m(-5\hat{i} - \hat{j})$$

And impulse received by  $M$

$$= -\vec{J} = m(5\hat{i} + \hat{j})$$

$$(b) mv = m(5\hat{i} + \hat{j})$$

$$\text{Or } v = \frac{m}{M}(5\hat{i} + \hat{j}) = \frac{1}{13}(5\hat{i} + \hat{j})$$

(c)  $e$  = (relative velocity of separation/relative velocity of approach) in the direction of  $-\vec{J} = 11/17$

317 (d)

Remains conserved until the torque acting on it remain zero

318 (c)

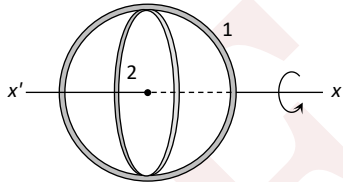

$$I_1 = \text{M.I. of ring about its diameter} = \frac{1}{2}mr^2$$

$$I_2 = \text{M.I. of ring about the axis normal to plane and passing through centre} = mr^2$$

Two rings are placed according to figure. Then

$$I_{xx'} = I_1 + I_2 = \frac{1}{2}mr^2 + mR^2 = \frac{3}{2}mr^2$$

319 (c)

$$\tau = \frac{dL}{dt}, \text{ if } \tau = 0 \text{ then } L = \text{constant}$$

320 (b)

If rod is rotated about end A, then vertical component of velocity  $v_{\perp}$  of end A will be zero.

$$\begin{aligned} \therefore \omega &= \frac{v \cos 60^\circ}{l} = \frac{\sqrt{3}v}{2l} \\ &= \frac{\sqrt{3} \times 3}{2 \times 0.5} = 5.2 \text{ rads}^{-1} \end{aligned}$$

321 (b)

In pure rolling, mechanical energy remains conserved. Therefore, when heights of inclines are equal, speed of sphere will be same in both the cases. But as acceleration down the incline,  $a \propto \sin \theta$  therefore, acceleration and time of descent will be different



322

(d)

The compression of spring is maximum when velocities of both blocks  $A$  and  $B$  is same. Let it be  $v_0$ , then from conservation law of momentum

$$mv = mv_0 + mv_0 = 2mv_0 \Rightarrow v_0 = \frac{v}{2}$$

$\therefore$  kinetic energy of  $A - B$  system at that stage

$$= \frac{1}{2}(m + m) \times \left(\frac{v}{2}\right)^2 = \frac{mv^2}{4}$$

Further loss in KE = gain in elastic potential energy

$$\text{ie, } \frac{1}{2}mv^2 - \frac{1}{4}mv^2 = \frac{1}{4}mv^2 = \frac{1}{2}kx^2$$

$$\Rightarrow x = v\sqrt{\frac{m}{2k}}$$

323

(c)

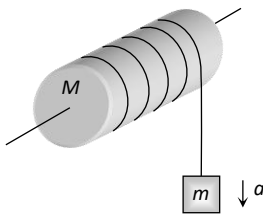

$$a = \frac{g}{1 + \frac{K^2}{R^2}} \quad [\text{For solid cylinder } \frac{K^2}{R^2} = \frac{1}{2}]$$

$$\therefore a = \frac{g}{1 + \frac{1}{2}} = \frac{2}{3}g$$

324

(a)

For translatory motion the force should be applied on the centre of the mass of the body. So we have to calculate the location of centre of mass of 'T' shaped object.

Let mass of rod  $AB$  is  $m$  so the mass of the rod  $CD$  will be  $2m$

Let  $y_1$  is the centre of mass of rod  $AB$  and  $y_2$  is the centre of mass of rod  $CD$ . We can consider that whole mass of the rod is placed at their respective centre of mass i. e., mass  $m$  is placed at  $y_1$  and mass  $2m$  is placed at  $y_2$

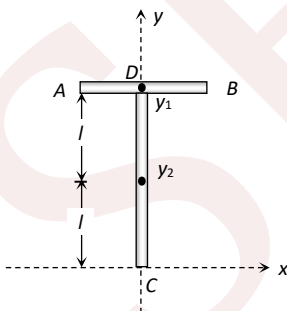

Taking point 'C' at the origin position vector of point  $y_1$  and  $y_2$  can be written as  $\vec{r}_1 = 2l\hat{j}$ ,  $\vec{r}_2 = l\hat{j}$  and  $m_1 = m$  and  $m_2 = 2m$

Position vector of centre of mass of the system

$$\vec{r}_{cm} = \frac{m_1\vec{r}_1 + m_2\vec{r}_2}{m_1 + m_2} = \frac{m2l\hat{j} + 2ml\hat{j}}{m + 2m} = \frac{4ml\hat{j}}{3m} = \frac{4}{3}l\hat{j}$$

Hence the distance of centre of mass from  $C = \frac{4}{3}l$

325

(a)

According to the equation of motion of the centre of mass



$$M \mathbf{a}_{CM} = \mathbf{F}_{ext}$$

If  $\mathbf{F}_{ext} = 0$ ,  $\mathbf{a}_{CM} = 0$

$\therefore \mathbf{v}_{CM} = \text{constant}$

ie, if no external force acts on a system the velocity of its centre of mass remains constant. Thus, the centre of mass may move but not accelerate.

327

**(d)**

When a body rolls down an inclined plane, it is accompanied by rotational and translational kinetic energies.

$$\text{Rotational kinetic energy} = \frac{1}{2} I \omega^2 = K_R$$

Where  $I$  is moment of inertia and  $\omega$  the angular velocity.

Translational kinetic energy

$$= \frac{1}{2} m v^2 = K_r = \frac{1}{2} m (r\omega)^2$$

where  $m$  is mass,  $v$  the velocity and  $\omega$  the angular velocity.

Given,

Translational KE = rotational KE

$$\frac{1}{2} m v^2 = \frac{1}{2} I \omega^2$$

Since,  $v = r\omega$

$$\therefore \frac{1}{2} m (r^2 \omega^2) = \frac{1}{2} I \omega^2$$

$$\Rightarrow I = m r^2$$

We know that  $m r^2$  is the moment of inertia of hollow cylinder about its axis is where  $m$  is mass of hollow cylindrical body and  $r$  the radius of cylinder.

328

**(a)**

When a body rolls down without slipping along an inclined plane of inclination  $\theta$ , it rotates about a horizontal axis through its centre of mass and also its centre of mass moves. Therefore, rolling motion may be regarded as a rotational motion about an axis through its centre of mass plus a translational motion of the centre of mass. As it rolls down, it suffers loss in gravitational potential energy provided translational energy due to frictional force is converted into rotational energy.

329

**(c)**

Given that,

Mass of solid sphere,  $m = 2 \text{ kg}$

Velocity,  $v = 10 \text{ ms}^{-1}$

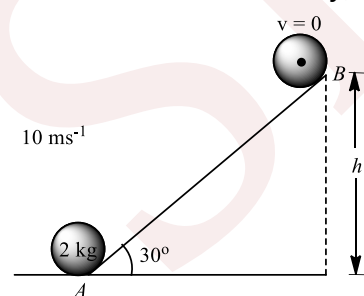

Let the sphere attained a height  $h$ .

When the sphere is at point A, it possesses kinetic energy and rotational kinetic energy, and when it is at point B it possesses only potential energy.

So, from law of conservation of energy

$$\frac{1}{2} m v^2 + \frac{1}{2} I \omega^2 = mgh$$

$$\text{or } \frac{1}{2} m v^2 + \frac{1}{2} m K^2 \times \frac{v^2}{R^2} = mgh$$



or  $\frac{1}{2}mv^2 \left[1 + \frac{K^2}{R^2}\right] = mgh$

or  $\frac{1}{2} \times (10)^2 \left[1 + \frac{2}{5}\right] = 9.8 \times h$

(for solid sphere,  $\frac{K^2}{R^2} = \frac{2}{5}$ )

or  $\frac{1}{2} \times 100 \times \frac{7}{5} = 9.8 \times h$

or  $h = 7.1 \text{ m}$

330 **(d)**

In the case of projectile motion, if bodies are projected with same speed, they reached at ground with same speeds. So, if bodies have same mass, then momentum of bodies or magnitude of momenta must be same

331 **(a)**

$$a = \frac{g \sin \theta}{1 + \frac{K^2}{R^2}} = \frac{g \sin 30^\circ}{1 + \frac{1}{2}} = \frac{g/2}{3/2} = \frac{g}{3}$$

332 **(c)**

This is an example of elastic oblique collision. When a moving body collides obliquely with another identical body in rest, then during elastic collision, the angle of divergence will be  $90^\circ$

333 **(c)**

Angular retardation,  $a = \frac{\tau}{I} = \frac{\mu mgR}{mR^2} = \frac{\mu g}{R}$

As,  $\omega = \omega_0 - \alpha t$

$$\therefore t = \frac{\omega_0 - \omega}{\alpha} = \frac{\omega_0 - \omega_0/2}{\mu g/R} = \frac{\omega_0 R}{2\mu g}$$

334 **(d)**

$$\frac{1}{2}mv^2 = \frac{1}{2}I \left(\frac{v}{R}\right)^2 = mg \left(\frac{3v^2}{4g}\right)$$

$$\therefore I = \frac{1}{2}mR^2$$

$\therefore$  Body is disc.

335 **(a)**

$$I = \frac{1}{2}MR^2 = \frac{1}{2} \times 0.5 \times (0.1)^2 = 2.5 \times 10^{-3} \text{ kg} \cdot \text{m}^2$$

336 **(c)**

$$\vec{v}_{cm} = \frac{m_1 \vec{v}_1 + m_2 \vec{v}_2}{m_1 + m_2} = \frac{200 \times 10\hat{i} + 500 \times (3\hat{i} + 5\hat{j})}{200 + 500}$$

$$\vec{v}_{cm} = 5\hat{i} + \frac{25}{7}\hat{j}$$

337 **(c)**

Given,  $I = \frac{2}{5}MR^2$

Using the theorem of parallel axes, moment of inertia of the sphere about a parallel axis tangential to the sphere is

$$I' = I + MR^2 = \frac{2}{5}MR^2 + MR^2 = \frac{7}{5}MR^2$$

$$\therefore I' = MK^2 = \frac{7}{5}MR^2, \quad K = \left(\sqrt{\frac{7}{5}}\right)R$$

338 **(d)**

$TE_i = TE_r$



$$\frac{1}{2}I\omega^2 = mgh$$

$$\frac{1}{2} \times \frac{1}{3}ml^2\omega^2 = mgh$$

$$\Rightarrow h = \frac{1}{6} \frac{l^2\omega^2}{g}$$

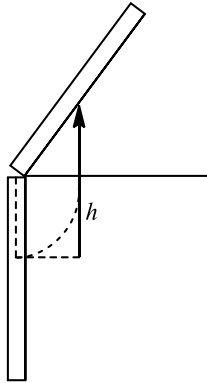

339

**(b)**

The ratio of rotational kinetic energy to total kinetic energy is

$$\frac{KE_R}{KE_T} = \frac{\frac{1}{2}I\omega^2}{\frac{1}{2}I\omega^2 + \frac{1}{2}Mv^2}$$

The moment of inertia of a ring

$$= \frac{1}{2}MR^2$$

$$\therefore \frac{KE_R}{KE_T} = \frac{\frac{1}{2}(\frac{1}{2}MR^2)\left[\frac{v}{R}\right]^2}{\frac{1}{2} \times \frac{1}{2}MR^2\left[\frac{v}{R}\right]^2 + \frac{1}{2}Mv^2}$$

$$= \frac{\frac{1}{2}(\frac{1}{2}Mv^2)}{\frac{1}{2}(\frac{1}{2}Mv^2) + \frac{1}{2}Mv^2}$$

$$\frac{KE_R}{KE_T} = \frac{1}{3}$$

340

**(c)**

From  $t_1 = 0$  to  $t_2 = 2t_0$  the external force acting on the combined system is  $m_1g + m_2g$

$\therefore$  Total change in momentum of system

$$= Ft = (m_1 + m_2)g2t_0$$

341

**(a)**

In explosion of a bomb, only kinetic energy, changes as initial kinetic energy is zero

342

**(d)**

Solid and hollow balls can be distinguished by any of the three methods.  $I_h > I_s$ . When torques are equal, angular acceleration  $\alpha$  of hollow must be smaller than  $\alpha$  of solid. Similarly, on rolling, solid ball will reach the bottom before the hollow ball

343

**(b)**

The acceleration of centre of mass is

$$a_{CM} = \frac{F}{m_A + m_B}$$

$$= \frac{30}{10 + 20} = 1 \text{ms}^{-2}$$

$$\therefore s = \frac{1}{2}a_{CM}t^2 = \frac{1}{2} \times 1 \times 2^2 = 2 \text{ m}$$

344

**(a)**

$$L = \sqrt{2EI} = \sqrt{2 \times 10 \times 8 \times 10^{-7}} = 4 \times 10^{-3} \text{kg m}^2/\text{s}$$



345

(b)

The acceleration of the body which is rolling down an inclined plane of angle  $\alpha$  is

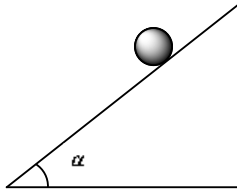

$$a = \frac{g \sin \alpha}{1 + \frac{K^2}{R^2}}$$

where  $K$  = radius of gyration,

$R$  = radius of body.

Now, here the body is a uniform solid disc.

So,  $\frac{K^2}{R^2} = \frac{1}{2}$

$\therefore a = \frac{g \sin \alpha}{1 + \frac{1}{2}}$

or  $a = \frac{g \sin \alpha}{3/2}$

or  $a = \frac{2g \sin \alpha}{3}$

347

(d)

Radius of gyration of circular disc  $k_{disc} = \frac{R}{\sqrt{2}}$

Radius of gyration of circular ring  $k_{ring} = R$

Ratio =  $\frac{k_{disc}}{k_{ring}} = \frac{1}{\sqrt{2}}$

348

(c)

There is a point in the system, where if whole mass of the system is supposed to be concentrated, the nature of the motion executed by the system remains unaltered when the force acting on the system are applied directly at this point.

The position of centre of mass of system for  $n$  particles is expressed as

$$R_{CM} = \frac{\sum m_i r_i}{\sum m_i}$$

or  $\sum m_i r_i = \text{constant}$

Hence, for a system having particles, we have

$$\begin{aligned} m_1 r_1 &= m_2 r_2 \\ \Rightarrow \frac{r_1}{r_2} &= \frac{m_2}{m_1} \end{aligned}$$

ie, the centre of mass of a system of two particle divides the distance between them in inverse ratio of masses of particles.

349

(d)

Angular momentum,  $L = mvr = m\omega r^2 = m \times \frac{2\pi}{T} \times r^2$

$$= \frac{2 \times 3.14 \times 6 \times 10^{24} \times (1.5 \times 10^{11})^2}{3.14 \times 10^7} = 2.7 \times 10^{40} \text{ kg} \cdot \text{m}^2/\text{s}$$

350

(d)

Change in momentum =  $\vec{F} t$  and does not depend on mass of the bodies.

351

(c)

From the triangle  $BCD$

$$CD^2 = BC^2 - BD^2 = a^2 - \left(\frac{a}{2}\right)^2$$



$$x^2 = \frac{3a^2}{4} \Rightarrow x = \frac{\sqrt{3}a}{2}$$

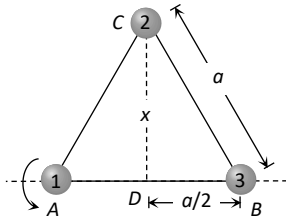

Moment of inertia of system along the side AB

$$I_{\text{system}} = I_1 + I_2 + I_3 = m \times (0)^2 + m \times (x)^2 + m \times (0)^2$$

$$= mx^2 = m \left( \frac{\sqrt{3}a}{2} \right)^2 = \frac{3ma^2}{4}$$

352 (a)

The moment of inertia of ring =  $MR^2$

The moment of inertia of removed sector =  $\frac{1}{4}MR^2$

The moment of inertia of remaining part =  $MR^2 - \frac{1}{4}MR^2$   
 $= \frac{3}{4}MR^2$

According to question, the moment of inertia of the remaining part =  $kMR^2$

then,  $k = \frac{3}{4}$

353 (a)

$$\frac{ML^2}{12} = MK^2 \Rightarrow K = \frac{L}{\sqrt{12}}$$

354 (c)

$$I = m_1 r_1^2 + m_2 r_2^2 = 2(0.3)^2 + 1(0.3)^2 = 0.27 \text{ kg m}^2$$

355 (a)

As two solid spheres are equal in masses, so

$$m_A = m_B$$

$$\Rightarrow \frac{4}{3}\pi R_A^3 \rho_A = \frac{4}{3}\pi R_B^3 \rho_B$$

$$\Rightarrow \frac{R_A}{R_B} = \left( \frac{\rho_B}{\rho_A} \right)^{1/3}$$

The moment of inertia of sphere about diameter

$$I = \frac{2}{5}mR^2$$

$$\Rightarrow \frac{I_A}{I_B} = \left( \frac{R_A}{R_B} \right)^2 \quad (\text{as } m_A = m_B)$$

$$\Rightarrow \frac{I_A}{I_B} = \left( \frac{\rho_B}{\rho_A} \right)^{2/3}$$

356 (d)

$$\text{Linear kinetic energy} = \frac{1}{2}mv^2$$

$$\text{Rotational kinetic energy} = \frac{1}{2}I\omega^2$$

$$= \frac{1}{2} \left( \frac{2}{5}mr^2 \right) \frac{v^2}{r^2}$$

$$= \frac{1}{5}mv^2$$

$$\text{Total KE} = \frac{1}{2}mv^2 + \frac{1}{5}mv^2$$



$$= \frac{7}{10}mv^2$$

$$\text{Required fraction} = \frac{\frac{1}{5}mv^2}{\frac{7}{10}mv^2}$$

$$= \frac{1}{5} \times \frac{10}{7} = \frac{2}{7}$$

358 (a)

Moment of inertia of big drop is  $I = \frac{2}{5}MR^2$ . When small droplets are formed from big drop volume of liquid remain same

$$n \frac{4}{3}\pi r^3 = \frac{4}{3}\pi R^3$$

$$\Rightarrow n^{1/3}r = R$$

as  $n = 8$

$$\Rightarrow r = \frac{R}{2}$$

Mass of each small droplet =  $\frac{M}{8}$

∴ Moment of inertia of each small droplet

$$= \frac{2}{5} \left[ \frac{M}{8} \right] \left[ \frac{R}{2} \right]^2$$

$$= \frac{1}{32} \left[ \frac{2}{5}MR^2 \right] = \frac{I}{32}$$

359 (b)

$$\frac{L_{\text{Total}}}{L_B} = \frac{(I_A + I_B)\omega}{I_B\omega} \quad (\text{as } \omega \text{ will be same in both cases})$$

$$= \frac{I_A}{I_B} + 1 = \frac{m_A r_A^2}{m_B r_B^2} + 1$$

$$= \frac{r_A}{r_B} + 1 \quad (\text{as } m_A r_A = m_B r_B)$$

$$= \frac{11}{2.2} + 1 \quad (\text{as } r \propto \frac{1}{m})$$

$$= 6$$

∴ The correct answer is 6.

360 (b)

Moment of inertia of a rod about one end =  $\frac{ML^2}{3}$

As,  $I = I_1 + I_2 + I_3$

$$\therefore I = 0 + \frac{ML^2}{3} + \frac{ML^2}{3} = \frac{2ML^2}{3}$$

361 (d)

Total kinetic energy =  $\frac{1}{2}mv^2 \left( 1 + \frac{K^2}{R^2} \right) = 32.8 J$

$$\Rightarrow \frac{1}{2} \times 10 \times (2)^2 \left( 1 + \frac{K^2}{(0.5)^2} \right) = 32.8 \Rightarrow K = 0.4 m$$

362 (a)

Kinetic energy of rotating body =  $\frac{1}{2}I\omega^2$

$$= \frac{1}{2} \times 3 \times (3)^2 = 13.5 J$$

Kinetic energy of translating body =  $\frac{1}{2}mv^2$

As both are equal according to problem *i. e.*

$$\frac{1}{2}mv^2 = 13.5 \Rightarrow \frac{1}{2} \times 27 \times v^2 = 13.5 \Rightarrow \therefore v = 1 m/s$$



363 (d)  
According to conservation of momentum

$$5 \times 10 = (955 + 5)v$$

$$v = \frac{50}{100} = \frac{1}{20} \quad \therefore \% \text{ KE lost} = \frac{K_1 - K_2}{K_1} \times 100 = 95.5\%$$

364 (d)  
Total moment of inertia will be equal to the sum of moment of inertia due to individual masses.

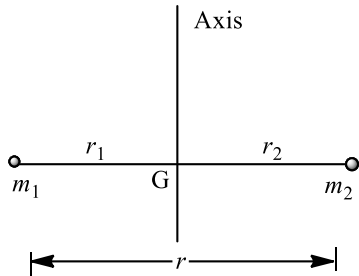

$$I = \sum_{i=1}^n I_i$$

where,  $I_1 = m_1 r_1^2, I_2 = m_2 r_2^2$ .

Given,  $r = r_1 + r_2$

$$m_1 r_1 = m_2 r_2$$

$$\therefore m_1 r_1 = m_2 (r - r_1)$$

$$\Rightarrow m_1 r_1 + m_2 r_1 = m_2 r$$

$$\Rightarrow r_1 (m_1 + m_2) = m_2 r$$

$$\Rightarrow r_1 = \frac{m_2 r}{(m_1 + m_2)}$$

Also,  $r_2 = r - r_1$

$$r_2 = r - \frac{m_2 r}{(m_1 + m_2)} = \frac{m_1 r}{m_1 + m_2}$$

$$\therefore I = I_1 + I_2 = m_1 r_1^2 + m_2 r_2^2$$

$$I = m_1 \frac{m_2^2 r^2}{(m_1 + m_2)^2} + m_2 \frac{m_1^2 r^2}{(m_1 + m_2)^2}$$

$$I = \frac{m_1 m_2 r^2}{(m_1 + m_2)} = \frac{m_1 m_2}{(m_1 + m_2)} \cdot r^2$$

365 (b)  
$$\alpha = \frac{\omega_2 - \omega_1}{t} = \frac{2\pi(n_2 - n_1)}{t} = \frac{2\pi \times \left[ \frac{240}{60} - 0 \right]}{10}$$

$$\therefore \alpha = 2.51 \text{ rad/s}$$

366 (a)  
$$\alpha = \frac{\omega}{t} = \frac{2\pi n}{t} = \frac{2\pi \left( \frac{540}{60} \right)}{6} = 3\pi \text{ rad/s}^2$$

367 (a)

Moment of inertia of the system about  $yy'$

$I_{yy'}$  = Moment of inertia of sphere P about

$yy'$  + Moment of inertia of sphere Q about  $yy'$

Moment of inertia of sphere P about  $yy''$

$$= \frac{2}{5} M \left( \frac{R}{2} \right)^2 + M(x)^2$$



$$= \frac{2}{5}M \left(\frac{R}{2}\right)^2 + M(2R)^2$$

$$= \frac{MR^2}{10} + 4MR^2$$

Moment of inertia of sphere  $Q$  about  $yy''$  is  $\frac{2}{5}M \left(\frac{R}{2}\right)^2$

$$\text{Now, } I_{yy'} = \frac{MR^2}{10} + 4MR^2 + \frac{2}{5}M \left(\frac{R}{2}\right)^2 = \frac{21}{5}MR^2$$

368 **(b)**

$$I = mR^2 = m \left(\frac{D^2}{4}\right) \Rightarrow I \propto mD^2 \text{ or } m \propto \frac{I}{D^2}$$

$$\therefore \frac{m_1}{m_2} = \frac{I_1}{I_2} \times \left(\frac{D_2}{D_1}\right)^2 = \frac{2}{1} \left(\frac{1}{2}\right)^2 = \frac{2}{4} = \frac{1}{2}$$

370 **(a)**

$$\vec{L} = \vec{r} \times \vec{p} = \begin{vmatrix} \hat{i} & \hat{j} & \hat{k} \\ 1 & 2 & -1 \\ 3 & 4 & -2 \end{vmatrix} = -\hat{j} - 2\hat{k}$$

and the  $X$  - axis is given by  $\hat{i} + 0\hat{j} + 0\hat{k}$

Dot product of these two vectors is zero *i. e.* angular momentum is perpendicular to  $X$  - axis

371 **(c)**

The rolling sphere has rotational as well as translational kinetic energy

$$\therefore \text{Kinetic energy} = \frac{1}{2}mu^2 + \frac{1}{2}I\omega^2$$

$$= \frac{1}{2}mu^2 + \frac{1}{2}\left(\frac{2}{5}mr^2\right)\omega^2 = \frac{1}{2}mu^2 + \frac{mu^2}{5} = \frac{7}{10}mu^2$$

Potential energy = kinetic energy

$$\therefore mgh = \frac{7}{10}mu^2 \Rightarrow h = \frac{7u^2}{10g}$$

372 **(d)**

$$\tau = r \times F$$

$$= r \times T$$

$$= r \times m \times g$$

$$= 0.1 \times 10 \times 9.8$$

$$= 9.8 \text{ N-m}$$

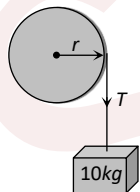

373 **(d)**

The moment of inertia of a circular disc

$$I = \frac{1}{2}MR^2$$

According to theorem of parallel axes

$$I' = \frac{1}{2}MR^2 + MR^2 = \frac{3}{2}MR^2 = 3I$$

374 **(b)**

$$\text{Rotational kinetic energy} = \frac{1}{2}I\omega^2$$

$$\therefore \text{Rotational KE} = \frac{1}{2}\left[\frac{1}{2}mr^2\right]\frac{v^2}{r^2} \quad (\text{where } I = \frac{1}{2}mr^2)$$



$$4 = \frac{1}{2} \left[ \frac{1}{2} (2)r^2 \right] \frac{v^2}{r^2}$$

$$\Rightarrow v^2 = 8$$

$$v = 2\sqrt{2} \text{ ms}^{-1}$$

376 (b)

As shown in figure normal reaction  $R = mg$ . Frictional force  $F = \mu R = \mu mg$ . To topple, clockwise moment must be more than the anticlockwise moment i.e.,  $\mu mg \times \frac{h}{2} > mg \times \frac{a}{2}$  or  $\mu > a/h$

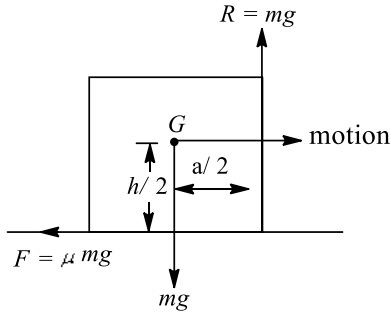

378 (c)

Angle turned in three second,  $\theta_{3s} = 2\pi \times 10 = 20\pi \text{ rad}$

From  $\theta = \omega_0 t + \frac{1}{2} \alpha t^2 \Rightarrow 20\pi = 0 + \frac{1}{2} \alpha \times (3)^2$

$$\Rightarrow \alpha = \frac{40\pi}{9} \text{ rad/s}^2$$

Now angle turned in 6 sec from the starting

$$\theta_{6s} = \omega_0 t + \frac{1}{2} \alpha t^2 = 0 + \frac{1}{2} \times \left( \frac{40\pi}{9} \right) \times (6)^2 = 80\pi \text{ rad}$$

$\therefore$  angle turned between  $t = 3s$  to  $t = 6s$

$$\theta_{\text{last } 3s} = \theta_{6s} - \theta_{3s} = 80\pi - 20\pi = 60\pi$$

$$\text{Number of revolution} = \frac{60\pi}{2\pi} = 30 \text{ rev}$$

379 (a)

$$x_{\text{CM}} = \frac{\int x dm}{\int dm}$$

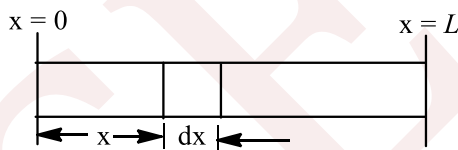

If  $n = 0$

$$\text{Then } x_{\text{CM}} = \frac{L}{2}$$

As  $n$  increases, the centre of mass shift away from  $x = \frac{L}{2}$  which only option (a) is satisfying.

Alternately, you can use basic concept.

$$x_{\text{CM}} = \frac{\int_0^L k \left( \frac{x}{L} \right)^n \times x dx}{\int_0^L k \left( \frac{x}{L} \right)^n dx}$$

$$= L \left[ \frac{n+1}{n+2} \right]$$

380 (d)

$$\vec{v}_{\text{cm}} = \frac{m_1 \vec{v}_1 + m_2 \vec{v}_2}{m_1 + m_2} = \frac{2 \times 3 + 3 \times 2}{2 + 3} = \frac{12}{5} = 2.4 \text{ m/s}$$

381 (c)

M.I. of the plate about an axis perpendicular to its plane and passing through its centre



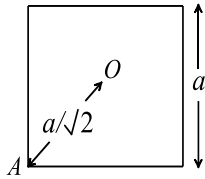

$$I_0 = \frac{ma^2}{6}$$

By parallel axes theorem

$$I_A = I_0 + m\left(\frac{a}{\sqrt{2}}\right)^2 = \frac{2}{3}ma^2$$

382

(c)

Moment of inertia of a disc

$$I = \frac{1}{2}MR^2$$

Disc is melted and recasted into a solid sphere.

∴ Volume of sphere = Volume of disc

$$\frac{4}{3}\pi R_1^3 = \pi R^2 \times \frac{R}{6}$$

$$\frac{4}{3}R_1^3 = \frac{R^3}{6}$$

$$R_1^3 = \frac{R^3}{8} \Rightarrow R_1 = \frac{R}{2}$$

∴ Moment of inertia of sphere

$$I' = \frac{2}{5}MR_1^2 = \frac{2}{5}M\left(\frac{R}{2}\right)^2 = \frac{2MR^2}{5 \cdot 4} = \frac{1}{5}\left(\frac{1}{2}MR^2\right) = \frac{I}{5}$$

383

(c)

For solid cylinder,  $\theta = 30^\circ, K^2 = \frac{1}{2}R^2$

For hollow cylinder,  $\theta = ?, K^2 = R^2$

Using we find,

$$\frac{\left(1 + \frac{1}{2}\right)}{\sin 30^\circ} = \frac{1 + 1}{\sin \theta}$$

$$\therefore \sin \theta = \frac{2}{3} = 0.6667$$

$$\theta = 42^\circ$$

384

(c)

We can assume that three particles of equal mass  $m$  are placed at the corners of triangle

$$\vec{r}_1 = 0\hat{i} + 0\hat{j}, \vec{r}_2 = b\hat{i} + 0\hat{j}$$

$$\text{and } \vec{r}_3 = 0\hat{i} + h\hat{j}$$

$$\therefore \vec{r}_{cm} = \frac{m_1\vec{r}_1 + m_2\vec{r}_2 + m_3\vec{r}_3}{m_1 + m_2 + m_3}$$

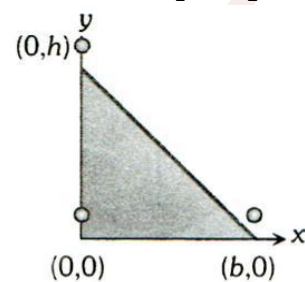

$$= \frac{b}{3}\hat{i} + \frac{h}{3}\hat{j}$$



i. e. coordinates of centre of mass is  $(\frac{b}{3}, \frac{h}{3})$

385 (d)

When a heavy body with velocity  $u$  collides with a lighter body at rest, then the heavier body remains moving in the same direction with almost same velocity. The lighter body moves in the same direction with a nearly velocity of  $2u$

386 (b)

Since, no force is present along the surface of plane so, momentum conservation principle for ball is applicable along the surface of plane.

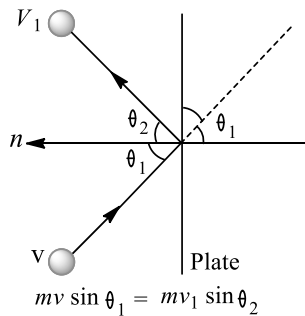

$$mv \sin \theta_1 = mv_1 \sin \theta_2$$

$$\text{Or } v \sin \theta_1 = v_1 \sin \theta_2$$

$$e = \frac{v_1 \cos \theta_2}{v \cos \theta_1} = \frac{v_1 \cos \theta_2}{v \cos \theta}$$

$$\therefore v_1 \cos \theta_2 = ev \cos \theta$$

$$\therefore \frac{v_1 \sin \theta_2}{v_1 \cos \theta_2} = \frac{v \sin \theta}{ev \cos \theta} = \frac{\tan \theta}{e}$$

$$\therefore \tan \theta = \frac{\tan \theta}{e}$$

$$\therefore \theta_2 = \tan^{-1} \left( \frac{\tan \theta}{e} \right)$$

387 (d)

We know that angular momentum of spin =  $I\omega$

By the conservation of angular momentum

$$\frac{2}{5}MR^2 \cdot \frac{2\pi}{T} = \frac{2}{5}M \left(\frac{R}{4}\right)^2 \cdot \frac{2\pi}{T'}$$

$$T' = \frac{T}{16} = \frac{24}{16} = 1.5h$$

388 (d)

Melting of ice produces water which will spread over larger distance away from the axis of rotation.

This increases the moment of inertia so angular velocity decreases

389 (c)

Hence,  $m_1 = 10 \text{ kg}$ ,  $m_2 = 4 \text{ kg}$

$$v_1 = 14\text{ms}^{-1}, v_2 = 0$$

$$v_{\text{CM}} = \frac{m_1 v_1 + m_2 v_2}{m_1 + m_2}$$

$$v_{\text{CM}} = \frac{10 \times 14 + 4 \times 0}{10 + 4} = 10\text{ms}^{-1}$$

390 (b)

Let centre of mass of lead sphere after hollowing be at point  $O_2$ , where  $OO_2 = x$



Mass of spherical hollow  $m = \frac{\frac{4}{3}\pi\left(\frac{R}{2}\right)^2 M}{\left(\frac{4}{2}\pi R^3\right)} = \frac{M}{8}$  and

$$x = OO_1 = \frac{R}{2}$$

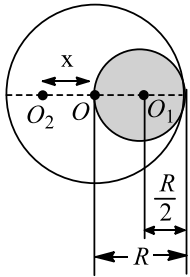

$$\therefore x = \frac{M \times 0 - \left(\frac{M}{8}\right) \times \frac{R}{2}}{M - \frac{M}{8}} = \frac{\frac{MR}{16}}{\frac{7M}{8}} = -\frac{R}{14}$$

$$\therefore \text{shift} = \frac{R}{14}$$

391 **(d)**

Angular momentum is given by

$$J = I\omega = \left(\frac{2MR^2}{5}\right)\omega$$

$$= \frac{2MR^2}{5} \times \frac{2\pi}{T} = \frac{4\pi MR^2}{5T}$$

392 **(a)**

Acceleration of each mass =  $a = \left(\frac{m_1 - m_2}{m_1 + m_2}\right)g$

Now acceleration of centre of mass of the system

$$A_{cm} = \frac{m_1 \vec{a}_1 + m_2 \vec{a}_2}{m_1 + m_2}$$

As both masses move with same acceleration but in opposite direction so  $\vec{a}_1 = -\vec{a}_2 = a$  (let)

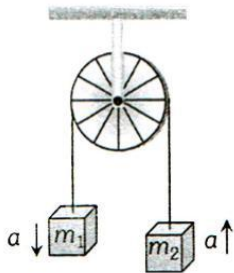

$$\therefore A_{cm} = \frac{m_1 a - m_2 a}{m_1 + m_2}$$

$$= \left(\frac{m_1 - m_2}{m_1 + m_2}\right) \times \left(\frac{m_1 - m_2}{m_1 + m_2}\right) \times g = \left(\frac{m_1 - m_2}{m_1 + m_2}\right)^2 \times g$$

393 **(c)**

If speed of man relative to plank be  $v$ , then it can be shown easily that speed of man relative to ground

$$v_{mg} = v \frac{M}{\left(M + \frac{M}{3}\right)} = \frac{3}{4}v$$

$\therefore$  Distance covered by man relative to ground

$$= L \frac{v_{mg}}{v} = \frac{L}{v} \frac{3}{4}v = \frac{3L}{4}$$

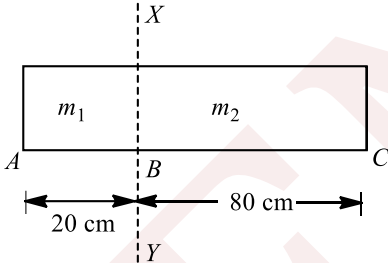

- 394 **(b)**  
 M.I. of disc =  $\frac{1}{2}MR^2 = \frac{1}{2}M\left(\frac{M}{\pi t\rho}\right) = \frac{1}{2}\frac{M^2}{\pi t\rho}$   
 (As  $\rho = \frac{M}{\pi R^2 t}$  Therefore  $R^2 = \frac{M}{\pi t\rho}$ )  
 If mass and thickness are same then,  $I \propto \frac{1}{\rho}$   
 $\therefore \frac{I_1}{I_2} = \frac{\rho_2}{\rho_1} = \frac{3}{1}$
- 395 **(a)**  
 If  $M = M'$  then bullet will transfer whole of its velocity (and consequently 100% of its KE) to block and will itself come to rest as per theory of collision.
- 397 **(c)**  
 Acceleration  $a = \frac{v-u}{t}$   
 Or  $a = \frac{v-v_0}{t}$   
 Or  $g = \frac{v-v_0}{t}$   
 $\therefore v = 0$   
 Speed before first bounce  
 $v_0 = -5\text{ms}^{-1}$   
 $\therefore t = \frac{v_B - v_A}{g} = \frac{0 - (-5)}{10} = \frac{5}{10} = 0.5 \text{ s}$
- 399 **(a)**  
 $m = 0.6 \text{ kg}$
- 
- Mass per unit length =  $\frac{0.6}{100} \text{ kgcm}^{-1}$   
 Mass of part AB,  $m_1 = \frac{0.6}{100} \times 20 = \frac{0.6}{5} \text{ kg}$   
 Mass of part BC,  $m_2 = \frac{0.6}{100} \times 80$   
 Moment of inertia =  $\frac{0.6 \times 4}{5} = \frac{2.4}{5} \text{ kg}$   

$$I = m_1 \left(\frac{AB}{2}\right)^2 + m_2 \left(\frac{BC}{2}\right)^2$$

$$= \frac{0.6}{5} \times \left(\frac{20}{2} \times 10^{-2}\right)^2 + \frac{2.4}{5} \times \left(\frac{80}{2} \times 10^{-2}\right)^2$$

$$= \frac{0.6}{5} \times 10^{-2} + \frac{2.4}{5} \times (4 \times 10^{-1})^2$$

$$= \frac{0.6}{5} \times 10^{-2} + \frac{2.4}{5} \times 16 \times 10^{-2}$$

$$= \left(\frac{0.6+38.4}{5}\right) \times 10^{-2}$$

$$= 7.8 \times 10^{-2} \text{ kg-m}^2 = 0.078 \text{ kg-m}^2$$
- 400 **(a)**  
 $P = \sqrt{p_x^2 + p_y^2}$



$$= \sqrt{(2 \cos t)^2 + (2 \sin t)^2} = 2$$

If  $m$  be the mass of the body, then kinetic energy

$$= \frac{p^2}{2m} = \frac{(2)^2}{2m} = \frac{2}{m}$$

Since kinetic energy does not change with time, both work done and power are zero

$$\text{Now Power} = Fv \cos \theta = 0$$

As  $F \neq 0, v \neq 0$

$$\therefore \cos \theta = 0$$

Or  $\theta = 90^\circ$

As direction of  $\vec{p}$  is same that  $\vec{v}$  ( $\because \vec{p} = m\vec{v}$ ) hence angle between  $\vec{F}$  and  $\vec{p}$  is equal to  $90^\circ$

401 **(b)**

Moment of inertia of a ring about an axis passing through the centre  $= MR^2 = 1 \times R^2 = 4$ , as  $M = 1 \text{ kg}$

$$\therefore R = 2m, \text{ Diameter } D = 2R = 4m$$

402 **(b)**

$$\tau = \frac{dL}{dt} = m(u^2 \cos^2 \theta) = (1)(10)^2 \cos^2 45^\circ = 50 \text{ Nm}$$

403 **(b)**

We calculate moment of inertia of the system about  $AD$

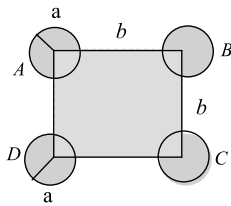

Moment of inertia of each of the sphere  $A$  and  $D$  about

$$AD = \frac{2}{5} Ma^2$$

Moment of inertia of each of the sphere  $B$  and  $C$  about  $AD$

$$= \left( \frac{2}{5} Ma^2 + Mb^2 \right)$$

Using theorem of parallel axes

$\therefore$  Total moment of inertia

$$I = \left( \frac{2}{5} Ma^2 \right) \times 2 + \left( \frac{2}{5} Ma^2 + Mb^2 \right) \times 2$$

$$= \frac{8}{5} Ma^2 + 2Mb^2$$

404 **(b)**

$$\theta = \omega_0 t + \frac{1}{2} \alpha t^2 = 2 \times 2 + \frac{1}{2} \times 3 \times (2)^2 = 10 \text{ rad}$$

405 **(d)**

Sphere possesses both translational and rotational kinetic energy

406 **(c)**

$$a = \frac{g \sin \theta}{1 + \frac{K^2}{R^2}} = \frac{g \sin 30^\circ}{1 + 1} = \frac{g}{4}$$

407 **(a)**

The circular disc of radius  $R$  rolls without slipping. Its centre of mass is  $C$  and  $P$  is point where body is in contact with the surface at any instant. At this instant, each particle of the body moving at right



angles to the line which joins the particle with point  $P$  with velocity proportional to distance. In other words, the combined translational and rotational motion is equal to

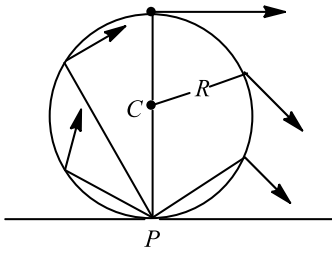

pure rotation and body moves constant in magnitude as well as direction.

408 (c)

$$\theta = \omega_0 t + \frac{1}{2} \alpha t^2 \Rightarrow 200 = \frac{1}{2} \alpha (5)^2 \Rightarrow \alpha = 16 \text{ rad/s}^2$$

409 (a)

$$Mg \sin \theta - f = Ma$$

$$fR = I \frac{a}{R} \Rightarrow a = \frac{g \sin \theta}{\left(1 + \frac{I}{MR^2}\right)}$$

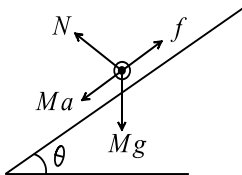

411 (b)

Since net external torque is equal to the rate of change of angular momentum

412 (c)

Conservation of angular momentum

$$I_1 \omega_1 + I_2 \omega_2 = (I_1 + I_2) \omega$$

$$\text{Angular velocity of system } \omega = \frac{I_1 \omega_1 + I_2 \omega_2}{I_1 + I_2}$$

$$\therefore \text{Rotational kinetic energy} = \frac{1}{2} (I_1 + I_2) \omega^2$$

$$= \frac{1}{2} (I_1 + I_2) \left( \frac{I_1 \omega_1 + I_2 \omega_2}{I_1 + I_2} \right)^2 = \frac{(I_1 \omega_1 + I_2 \omega_2)^2}{2(I_1 + I_2)}$$

413 (c)

$$I = \frac{ML^2}{12} = \frac{(m \times 2L) \times (2L)^2}{12} = \frac{m \times 2L \times 4L^2}{12} = \frac{2mL^3}{3}$$

414 (a)

$$\text{Given, } r = 0.4 \text{ m, } \alpha = 8 \text{ rad s}^{-2}$$

$$m = 4 \text{ kg, } I = ?$$

$$\text{Torque, } \tau = I\alpha = mgr \Rightarrow 4 \times 10 \times 0.4 = I \times 8$$

$$\Rightarrow I = \frac{16}{8} = 2 \text{ kg-m}^2$$

415 (c)

Moment of inertia of the system about axis AX,

$$= I_A + I_B + I_C$$

$$= m_A (r_A)^2 + m_B (r_B)^2 + m_C (r_C)^2$$

$$= m(0)^2 + m(l)^2 + m(l \cos 60)^2$$

$$= ml^2 + \frac{ml^2}{4} = \frac{5ml^2}{4}$$



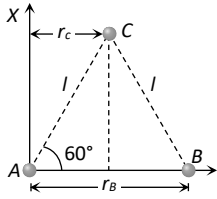

416 (a) Moment of inertia of system about point P

$$= 4m \left( \frac{l}{\sqrt{2}} \right)^2 = 2ml^2$$

$$\text{and } 4mK^2 = 2ml^2$$

$$\therefore K = \frac{l}{\sqrt{2}}$$

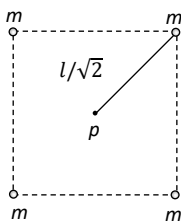

417 (a)

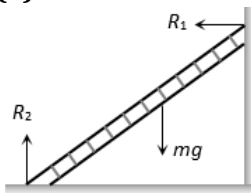

Due to net force in downward direction and towards left centre of mass will follow the path as shown in figure

418 (b)

$$\frac{\text{Rotational KE}}{\text{Total KE}} = \frac{\frac{1}{2}mv^2 \left( \frac{K^2}{R^2} \right)}{\frac{1}{2}mv^2 \left( 1 + \frac{K^2}{R^2} \right)} = \frac{K^2}{K^2 + R^2}$$

419 (b)

When the cylinder rolls up the incline, its angular velocity  $\omega$  is clockwise and decreasing



This requires an anticlockwise angular acceleration  $\alpha$ , which is provided by the force of friction ( $F$ ) acting up the incline

When the cylinder rolls down the incline, its angular velocity  $\omega$  is anticlockwise and increasing. This requires an anticlockwise angular acceleration  $\alpha$ , which is provided by the force of friction ( $F$ ) acting up the incline

420 (b)

$$E = \frac{L^2}{2I} \therefore E \propto L^2 \Rightarrow \frac{E_2}{E_1} = \left( \frac{L_2}{L_1} \right)^2$$

$$\frac{E_2}{E_1} = \left[ \frac{L_1 + 200\% \text{ of } L_1}{L_1} \right]^2 = \left[ \frac{L_1 + 2L_1}{L_1} \right]^2 = (3)^2 \Rightarrow E_2 = 9E_1$$



Increment in kinetic energy  $\Delta E = E_2 - E_1 = 9E_1 - E_1$

$$\Delta E = 8E_1 \therefore \frac{\Delta E}{E_1} = 8 \text{ or percentage increase} = 800\%$$

421

(a)

M.I. of system about the axis which passing through  $m_1$

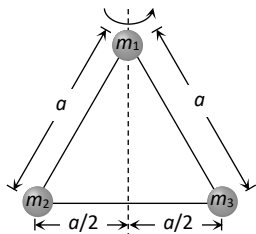

$$I_{\text{system}} = m_1(0)^2 + m_2\left(\frac{a}{2}\right)^2 + m_3\left(\frac{a}{2}\right)^2$$

$$I_{\text{system}} = (m_2 + m_3)\frac{a^2}{4}$$

422

(a)

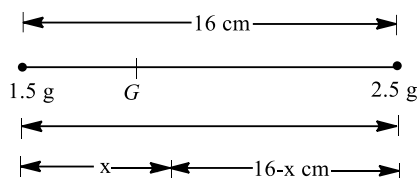

Taking the moment of forces about centre of gravity  $G$  is

$$(1.5)gx = 2.5g(16 - x)$$

$$\Rightarrow 3x = 80 - 5x$$

$$\text{or } 8x = 80 \quad \text{or } x = 10 \text{ cm}$$

423

(b)

Initially rod stand vertically its potential energy  $= mg \frac{l}{2}$

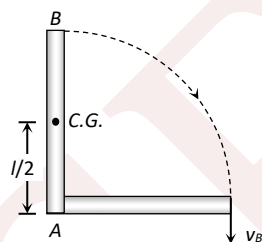

When it strikes the floor, its potential energy will convert into rotational kinetic energy

$$mg\left(\frac{l}{2}\right) = \frac{1}{2}I\omega^2$$

[Where,  $I = \frac{ml^2}{3}$  = M.I. of rod about point A]

$$\therefore mg\left(\frac{l}{2}\right) = \frac{1}{2}\left(\frac{ml^2}{3}\right)\left(\frac{v_B}{l}\right)^2 \Rightarrow v_B = \sqrt{3gl}$$

424

(b)

In free space neither acceleration due to gravity nor external torque act on the rotating solid space. Therefore, taking the same mass of sphere if radius is increased then moment of inertia, rotational kinetic energy and angular velocity will change but according to law of conservation of momentum, angular momentum will not change.

425

(b)

Rotational kinetic energy  $K_R = \frac{1}{2}I\omega^2$



$$K_R = \frac{1}{2} \times \frac{MR^2}{2} \times \omega^2 = \frac{1}{4}Mv^2 \quad [\because v = R\omega]$$

$$\text{Translational kinetic energy } K_T = \frac{1}{2}Mv^2$$

$$\text{Total kinetic energy} = K_T + K_R$$

$$= \frac{1}{2}Mv^2 + \frac{1}{4}Mv^2 = \frac{3}{4}Mv^2$$

$$\frac{\text{Rotational kinetic energy}}{\text{Total kinetic energy}} = \frac{\frac{1}{4}Mv^2}{\frac{3}{4}Mv^2} = \frac{1}{3}$$

426 (a)

$$\omega_0 = \frac{v}{r} = \frac{72 \times 5/18}{0.25} = 80 \text{ rad/s}$$

$$\omega = 0, \theta = 2\pi n = 2\pi \times 20 = 40\pi \text{ rad}$$

Substituting these value in equation

$$\omega^2 = \omega_0^2 + 2\alpha\theta$$

$$\Rightarrow \alpha = -\frac{\omega_0^2}{2 \times \theta} = -\frac{80 \times 80}{2 \times 40\pi} = -25.5 \text{ rad/s}^2$$

428 (a)

In case of pure rolling bottommost point is the instantaneous centre of zero velocity.

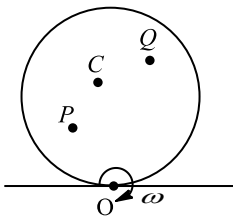

Velocity of any point on the disc,  $v = r\omega$ ,  
where  $r$  is distance of point from  $O$ .

$$r_Q > r_C > r_P$$

$$\therefore v_Q > v_C > v_P$$

429 (c)

The centre of mass is given by

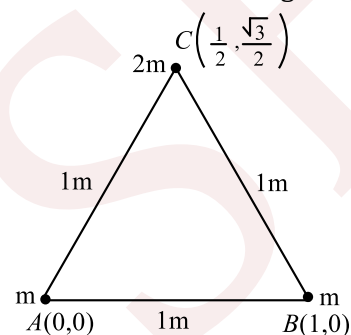

$$\bar{x} = \frac{m_1x_1 + m_2x_2 + m_3x_3}{m_1 + m_2 + m_3}$$

$$\bar{x} = \frac{m \times 0 + m \times 1 + 2m \times \left(\frac{1}{2}\right)}{m + m + 2m}$$

$$\bar{x} = \frac{2m}{4m} = \frac{1}{2}m$$

$$\bar{y} = \frac{m_1y_1 + m_2y_2 + m_3y_3}{m_1 + m_2 + m_3}$$

$$\bar{y} = \frac{m \times 0 + m \times 0 + 2m \times \sqrt{3}/2}{m + m + 2m}$$



$$= \frac{\sqrt{3}}{4}m$$

∴ Centre of mass is  $(\frac{1}{2}m, \frac{\sqrt{3}}{4}m)$ .

430 (c)

Angular momentum  $L = I\omega$  constant

∴  $I$  increases and  $\omega$  decreases

434 (a)

$$K = \frac{1}{2}mv^2 = \frac{1}{2} \times \frac{m(mv^2)}{2} = \frac{(mv)^2}{m} = \frac{(mv)^2}{2m} \text{ or } K = \frac{p^2}{2m}$$

$$\therefore \frac{K_1}{K_2} = \frac{p_1^2}{2m_1} \times \frac{2m_2}{p_2^2} \text{ or } \frac{3}{1} = \frac{p_1}{p_2} \times \frac{6}{2}$$

$$\therefore p_1 : p_2 = 1 : 1$$

435 (a)

As torque  $\tau = \frac{dL}{dt}$

If  $\tau = 0$ , then  $L = \text{constant}$ .

436 (d)

Here, torque  $\tau = 1.6 \times 1 = 1.6 \text{ Nm}$

So, when  $d = 0.4 \text{ m}$ ,

$$F = \frac{\tau}{d} = \frac{1.6}{0.4} = 4 \text{ N}$$

437 (d)

As is clear from figure,

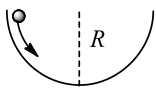

On reaching the bottom of the bowl, loss in PE =  $mgR$ , and

$$\text{Gain in KE} = \frac{1}{2}mv^2 + \frac{1}{2}I\omega^2$$

$$= \frac{1}{2}mv^2 + \frac{1}{2} \times \left(\frac{2}{5}mr^2\right)\omega^2$$

$$= \frac{1}{2}mv^2 + \frac{1}{5}mv^2 = \frac{7}{10}mv^2$$

As again in KE = loss in PE

$$\therefore \frac{7}{10}mv^2 = mgR$$

$$v = \sqrt{\frac{10gR}{7}}$$

438 (c)

The angular momentum of a moving particle  $J = 4\sqrt{t} \text{ kg m}^2\text{s}^{-1}$

Torque acting on a moving particle

$$\tau = \frac{dJ}{dt} = \frac{d}{dt}(4\sqrt{t}) = 4 \frac{d\sqrt{t}}{dt} = 4 \left(\frac{1}{2} t^{1/2-1}\right)$$

$$\tau = \frac{4}{2} t^{-1/2} \text{ Nm} = \frac{2}{\sqrt{t}} \text{ Nm}$$

439 (b)

Here initial momentum  $\vec{p} = 0$ . Since no external force exists, hence momentum must remain conserved ie,  $\vec{p}_1 + \vec{p}_2 + \vec{p}_3 = 0$

As two fragments of mass  $m$  each are moving with speed  $v$  each at right angles,

$$|\vec{p}_1 + \vec{p}_2| = m\sqrt{v^2 + v^2} = \sqrt{2}mv$$

$$\therefore |\vec{p}_3| = |\vec{p}_1 + \vec{p}_2| = 2mv.$$



The mass of third fragment is 2 m.

∴ Kinetic energies of three fragments are

$$K_1 = \frac{p_1^2}{2m} = \frac{1}{2}mv^2, K_2 = \frac{p_2^2}{2m} = \frac{1}{2}mv^2$$

$$\text{And } K_3 = \frac{p_3^2}{2(2m)} = \frac{1}{2}mv^2$$

Total kinetic energy released during explosion

$$= K_1 + K_2 + K_3 = \frac{3}{2}mv^2$$

440 **(a)**

$$\omega = \frac{v}{r} \Rightarrow \omega \propto \frac{1}{r}$$

441 **(d)**

As shown in figure,

$$x_{CM} = \frac{M \times 0 + M \times 20 + M \times 20 + M \times 0}{4M} = 10 \text{ cm}$$

Similarly  $y_{CM} = 10 \text{ cm}$

Hence, distance of centre of mass from centre of any one sphere,

$$\text{Say } r = \sqrt{(10 - 0)^2 + (10 - 0)^2} = 10\sqrt{2} \text{ cm}$$

442 **(c)**

$$I = I_{CM} + Mh^2 \text{ (Parallel axis theorem)}$$

444 **(b)**

If radius of earth decreases then its M.I. decreases

$$\text{As } L = I\omega \therefore \omega \propto \frac{1}{I} \text{ [} L = \text{constant]}$$

*i. e.* angular velocity of the earth will increase

445 **(c)**

$$\text{Kinetic energy } E = \frac{L^2}{2I}$$

If angular momenta are equal, then  $E \propto \frac{1}{I}$

Kinetic energy  $E = K$  (given in problem)

If  $I_A > I_B$  then  $K_A < K_B$ .

446 **(c)**

When a body is in equilibrium, net force is zero. Hence, acceleration is zero

447 **(d)**

$$K_N = \frac{1}{2}mv^2 \left( \frac{K^2}{R^2} + 1 \right) = \frac{1}{2} \times 2 \times (0.5)^2 \times \left( \frac{2}{3} + 1 \right) = 0.42J$$

448 **(d)**

$$\theta = \omega t = \frac{500 \times 2\pi}{60} = \frac{50\pi}{3} \text{ rad}$$

449 **(a)**

$$F = 20t - 5t^2$$

$$\alpha = \frac{FR}{I} = 4t - t^2$$

$$\Rightarrow \frac{d\omega}{dt} = 4t - t^2$$

$$\Rightarrow \int_0^\omega d\omega = \int_0^t (4t - t^2) dt$$

$$\Rightarrow \omega = 2t^2 - \frac{t^3}{3}$$

When direction is reversed,



$$\omega = 0, \text{ i.e., } t = 0, 6\text{s}$$

Now,  $d\theta = \omega dt$

$$\int_0^\theta d\theta = \int_0^6 \left(2t^2 - \frac{t^3}{3}\right) dt$$

$$\Rightarrow \theta = \left[\frac{2t^3}{3} - \frac{t^4}{12}\right]_0^6$$

$$\Rightarrow \theta = 144 - 108 = 36 \text{ rad}$$

$\therefore$  Number of rotations,

$$n = \frac{\theta}{2\pi} = \frac{36}{2\pi} < 6$$

450 **(d)**

Rotational kinetic energy,

$$\text{KE} = \frac{1}{2} I \omega^2$$

Here,  $\omega = 1 \text{ rads}^{-1}$

$$\therefore \text{KE} = \frac{1}{2} I \times I$$

or  $I = 2 \text{ KE}$

i.e., moment of inertia about an axis of a body is twice the rotational kinetic energy.

451 **(c)**

Here,  $\theta = 60^\circ, l = 10 \text{ m}, a = ?$

$$a = \frac{g \sin \theta}{1 + K^2/R^2}$$

For solid sphere,  $K^2 = \frac{2}{5} R^2$

$$a = \frac{9.8 \sin 60^\circ}{1 + \frac{2}{5}} = \frac{5}{7} \times 9.8 \times \frac{\sqrt{3}}{2} = 6.06 \text{ ms}^{-2}$$

453 **(d)**

Perpendicular to the orbital plane and along the axis of rotation

454 **(b)**

$$I = mr^2 = 10 \times (0.2)^2 = 0.4 \text{ kg} - \text{m}^2$$

$$\omega = 2\pi n = 2\pi \times \frac{2100}{60} \text{ rad/s}$$

$$\therefore L = I\omega = \frac{0.4 \times 2\pi \times 210}{6} = 88 \text{ kg} - \text{m}^2/\text{s}$$

455 **(b)**

If  $h$  is height of the ramp, then in rolling of marble, speed

$$v = \sqrt{\frac{2gh}{1 + K^2/R^2}}$$

The speed of the cube to the centre of mass

$$v' = \sqrt{2gh}$$

$$\therefore \frac{v'}{v} = \sqrt{1 + K^2/R^2}$$

For marble sphere,  $K^2 = \frac{2}{5} R^2$

$$\therefore \frac{v'}{v} = \sqrt{1 + \frac{2}{5}} = \sqrt{\frac{7}{5}} = \sqrt{7} : \sqrt{5}$$

457 **(c)**



$$\text{Moment of inertia} = \frac{1}{2} MR^2 + mx^2$$

Where  $m$  = mass of insect,

and  $x$  = distance of insect from centre.

Clearly, as the insect moves along the diameter of the disc, MI first decreases, then increases.

By conservation of angular momentum, angular speed first increases, then decreases.

458 **(b)**

We know that rate of change of angular momentum ( $J$ ) of a body is equal to the external torque ( $\tau$ ) acting upon the body.

$$\text{ie. } \frac{dJ}{dt} = \tau$$

$$\text{Given, } J_1 = J, J_2 = 5J$$

$$\therefore \Delta J = J_2 - J_1 = 5J - J = 4J$$

$$\text{Hence, } \tau = \frac{4}{5} J$$

459 **(b)**

Since,  $m_2$  moves with constant velocity

$$a = 2 \text{ ms}^{-1}, m_1 = 10 \text{ kg}, m_2 = 8 \text{ kg,}$$

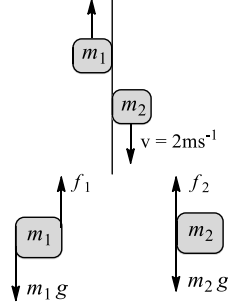

$$\therefore f_2 = m_2 g$$

$$f_2 = 8 \times 10 = 80 \text{ N}$$

Since, boy of mass  $m_1$  moves with acceleration  $a = 2 \text{ ms}^{-2}$  in upward direction

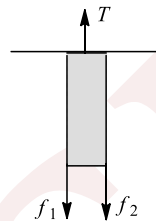

$$\therefore f_1 = m_1 g = m_1 a$$

$$\therefore f_1 = m_1 g = m_1 a$$

$$= 10 \times 10 + 10 \times 2 = 120 \text{ N}$$

460 **(c)**

According to the principle of conservation of angular momentum, in the absence of external torque, the total angular momentum of the system is constant.

461 **(a)**

As angular momentum is conserved in the absence of a torque, therefore

$$I_0 \omega_0 = I \omega$$

$$\left( \frac{2}{3} MR^2 \right) \left( \frac{2\pi}{T_0} \right) = \left[ \frac{2}{5} MR^2 + \frac{2}{5} \frac{MR^2}{5 \times 10^{19}} \right] \frac{2\pi}{T}$$

$$\frac{T}{T_0} = 1 + \frac{1}{5 \times 10^{19}}$$



$$\frac{T}{T_0} - 1 = \frac{1}{5 \times 10^{19}} = 2 \times 10^{-20}$$

$$\frac{T - T_0}{T_0} = 2 \times 10^{-20} \text{ or } \frac{\Delta T}{T_0} = 2 \times 10^{-20}$$

462

(a)

Let  $p_1$  and  $p_2$  be the momenta of  $A$  and  $B$  after collision.

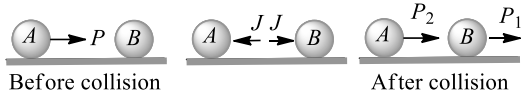

Then applying impulse = change in linear momentum for the two particles

For  $B : J = p_1 \quad \dots$  (i)

For  $A : J = p - p_2$

Or  $p_2 = p - J \quad \dots$  (ii)

Coefficient of restitution  $e = \frac{p_1 - p_2}{p}$

$$= \frac{p_1 - p + J}{p}$$

$$= \frac{J - p + J}{p} = \frac{2J}{p} = -1$$

463

(d)

Since  $\omega$  is constant,  $v$  would also be constant. So, no net force or torque is acting on ring. The force experienced by any particle is only along radial direction, or we can say the centripetal force.

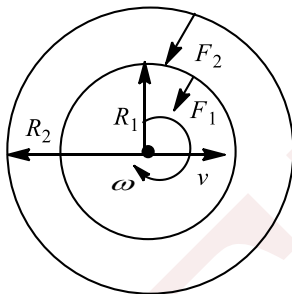

The force experienced by inner part,  $F_1 = m\omega^2 R_1$  and the force experienced by outer part,  $F_2 = m\omega^2 R_2$

$$\frac{F_1}{F_2} = \frac{R_1}{R_2}$$

464

(a)

Initial angular momentum of ring,  $L = I\omega = Mr^2\omega$

Final angular momentum of ring and four particles system

$$L = (Mr^2 + 4mr^2)\omega'$$

As there is no torque on the system therefore angular momentum remains constant

$$Mr^2\omega = (Mr^2 + 4mr^2)\omega' \Rightarrow \omega' = \frac{M\omega}{M + 4m}$$

465

(d)

Moment of inertia of square plate about  $XY$  is  $\frac{ma^2}{6}$

Moment of inertia about  $ZZ'$  can be computed using parallel axis theorem



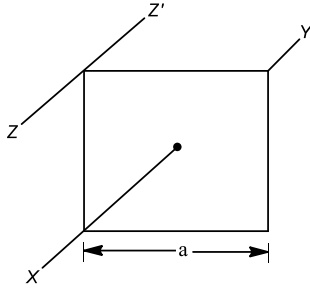

$$I_{ZZ'} = I_{XY} + m \left( \frac{a}{\sqrt{2}} \right)^2$$

$$= \frac{ma^2}{6} + \frac{ma^2}{2} = \frac{2ma^2}{3}$$

466

(a)

$$L = \frac{1}{2}MR^2\omega = \text{constant} \therefore \omega \propto \frac{1}{R^2} \text{ [If } m = \text{constant]}$$

If radius is reduced to half then angular velocity will be four times

467

(a)

$$y_{CM} = \frac{m_1y_1 + m_2y_2 + m_3y_3 + m_4y_4 + m_5y_5}{m_1 + m_2 + m_3 + m_4 + m_5}$$

$$= \frac{(6m)(0) + m(a) + m(a) + m(0) + m(-a)}{6m + m + m + m + m} = \frac{a}{10}$$

468

(a)

$$F_1x + F_2x = F_3x$$

$$F_3 = F_1 + F_2$$

470

(a)

Torque is defined as rate of change of angular momentum

$$\therefore \tau = \frac{dJ}{dt} = \frac{d(I\omega)}{dt}$$

$$\text{Given, } \tau = 40 \text{ Nm, } I = 5 \text{ kgm}^2, \omega = 24 \text{ rads}^{-1}$$

$$dt = \frac{d(I\omega)}{\tau} = \frac{5 \times 24}{40} = 3 \text{ s}$$

471

(b)

$$K_N = \frac{1}{2}mv^2 \left( 1 + \frac{K^2}{R^2} \right) = \frac{1}{2} \times 0.41 \times (2)^2 \times \left( \frac{3}{2} \right) = 1.23 \text{ J}$$

472

(b)

$$K_R = 50\%, K_T$$

$$\frac{1}{2}mv^2 \left( \frac{K^2}{R^2} \right) = \frac{50}{100} \times \frac{1}{2}mv^2 \Rightarrow \therefore \frac{K^2}{R^2} = \frac{1}{2}$$

i. e. body will be solid cylinder

473

(d)

From third equation of angular motion,

$$\omega^2 = \omega_0^2 = 2\alpha \quad (\text{Here, } \omega = \frac{\omega_0}{2}, \theta = 36 \times 2\pi)$$

$$\therefore \left( \frac{\omega_0}{2} \right)^2 = \omega_0^2 - 2\alpha \times 36 \times 2\pi$$

$$\text{or } 4 \times 36\pi\alpha = \omega_0^2 - \frac{\omega_0^2}{4}$$

$$\text{or } 4 \times 36\pi\alpha = \frac{3\omega_0^2}{4}$$

$$\text{or } \alpha = \frac{\omega_0^2}{16 \times 12\pi} \quad \dots(i)$$

According to question again applying the third equation of angular motion

$$\omega^2 = \omega_0^2 - 2\alpha\theta \quad (\text{Here, } \omega = 0)$$



$$\therefore 0 = \left(\frac{\omega_0}{2}\right)^2 - 2 \times \frac{\omega_0^2 \theta}{16 \times 12 \pi}$$

or  $\theta = 24\pi$  or  $\theta = 12 \times 2\pi$   
But  $2\pi = 1$  cycle  
So,  $\theta = 12$  cycle

474

**(d)**

$$I_P > I_Q$$

$$a_P = \frac{g \sin \theta}{I_P + mR^2}$$

$$a_Q = \frac{g \sin \theta}{I_Q + mR^2}$$

$$a_P > a_Q \Rightarrow V = u + at \Rightarrow t \propto \frac{1}{a}$$

$$t_P > t_Q$$

$$V^2 = u^2 + 2as \Rightarrow v \propto a \Rightarrow V_P < V_Q$$

$$\text{Translational K.E.} = \frac{1}{2}mV^2 \Rightarrow TR KE_P < TR KE_Q$$

$$V = \omega R \Rightarrow \omega \propto V \Rightarrow \omega_P < \omega_Q$$

475

**(c)**

Consider the two cart system as a single system. Due to explosion of power charge total momentum of system remains unchanged i.e.,  $\vec{p}_1 + \vec{p}_2 = 0$  or  $m_1 v_1 = m_2 v_2$ ,

Hence

$$\frac{v_1}{v_2} = \frac{m_2}{m_1}$$

As coefficient of friction between carts and rails are identical, hence  $a_1 = a_2$  and at the time of stopping final velocity of cart is zero. Using equation  $v^2 - u^2 = 2as$ ,

We have

$$\frac{s_1}{s_2} = \frac{v_1^2}{v_2^2} = \frac{m_2^2}{m_1^2} \Rightarrow s_2 = \frac{s_1 m_1^2}{m_2^2} = \frac{36 \times (200)^2}{(300)^2} = 16\text{m}$$

476

**(d)**

Moment of inertia of a circular disc about an axis passing through centre of gravity and perpendicular to its plane

$$I = \frac{1}{2} MR^2 \quad \dots(i)$$

From Eq.(i)

$$MR^2 = 2I$$

Then, moment of inertia of disc about tangent in a plane

$$= \frac{5}{4} MR^2 = \frac{5}{4} (2I) = \frac{5}{2} I$$

477

**(c)**

$$K_N = \frac{1}{2} m v^2 \left(1 + \frac{K^2}{R^2}\right) = \frac{1}{2} \times 50 \times (5)^2 \times \left(1 + \frac{2}{5}\right)$$

$$= 875 \text{erg}$$

479

**(a)**

$$x_1 + x_2 = r \quad \dots(i)$$

$$m_1 x_1 = m_2 x_2$$



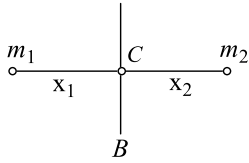

From Eqs. (i) and (ii)

$$x_1 = \frac{m_2 r}{m_1 + m_2}$$

and  $x_2 = \frac{m_1 r}{m_1 + m_2}$

$$\begin{aligned} \therefore I_{AB} &= m_1 x_1^2 + m_2 x_2^2 \\ &= \frac{m_1 m_2 r^2}{m_1 + m_2} \end{aligned}$$

480

**(d)**

Moment of inertia of the system about rod  $x$ , figure

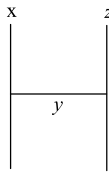

$$I = I_x + I_y + I_z = 0 + \left( \frac{Ml^2}{12} + \frac{Ml^2}{4} \right) + Ml^2$$

$$= \frac{4}{3} Ml^2$$

481

**(b)**

$$\frac{3}{2} MR^2 = \frac{3}{2} \times 2 \times (0.1)^2 = 0.03 \text{ kg} \cdot \text{m}^2$$

482

**(b)**

$$\vec{r}_{cm} = \frac{m_1 \vec{r}_1 + m_2 \vec{r}_2}{m_1 + m_2} = \frac{1(\hat{i} + 2\hat{j} + \hat{k}) + 3(-3\hat{i} - 2\hat{j} + \hat{k})}{1 + 3}$$

$$\Rightarrow \vec{r}_{cm} = -2\hat{i} - \hat{j} + \hat{k}$$

483

**(b)**

$$K = \frac{1}{2} m v^2 \left( 1 + \frac{k^2}{R^2} \right)$$

$$= \frac{1}{2} \times 0.41 \times (2)^2 \times \left( \frac{3}{2} \right)$$

$$= 1.23 \text{ J}$$

484

**(b)**

As net external force on the system is zero therefore position of their centre of mass remains unaffected i.e. they will hit each other at the point of centre of mass.

The centre of mass of the system lies nearer to  $A$  because  $m_A > m_B$

486

**(c)**

$$L_1 = L_2$$

$$I\omega - mvR = (I + mR^2)\omega' \Rightarrow \omega' = \frac{I\omega - mvR}{(I + mR^2)}$$

487

**(b)**

Moment of inertia of a ring of mass  $M$  and radius  $R$  about an axis passing through the centre and perpendicular to the plane

$$I = MR^2 \quad \dots(i)$$



Moment of inertia of a ring about its diameter

$$I_{\text{diameter}} = \frac{MR^2}{2} = \frac{I}{2} \quad [\text{Using (i)}]$$

488 **(b)**

Here,  $r = 0.5 \text{ m}$ ,  $m = 2 \text{ kg}$

$$\text{Rotational KE} = \frac{1}{2}I\omega^2 = \frac{1}{2} \times \left(\frac{1}{2}mr^2\right)\omega^2$$

$$4 = \frac{1}{4}mv^2 = \frac{1}{4} \times 2v^2$$

$$v = \sqrt{8} = 2\sqrt{2} \text{ ms}^{-1}$$

489 **(a)**

A hoop is a circular ring. Applying theorem of parallel axes,

$$I = I_0 + MR^2 = MR^2 + MR^2 = 2MR^2$$

490 **(c)**

$$m_1 = 1, m_2 = 35.5, \vec{r}_1 = 0, \vec{r}_2 = 1.27\hat{i}$$

$$\vec{r} = \frac{m_1\vec{r}_1 + m_2\vec{r}_2}{m_1 + m_2}$$

$$\vec{r} = \frac{35.5 \times 1.27}{1 + 35.5} \hat{i}$$

$$\vec{r} = \frac{35.5}{36.5} \times 1.27\hat{i} = 1.24\hat{i}$$

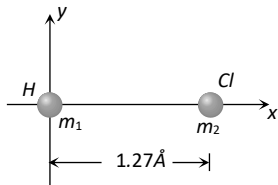

491 **(c)**

The rolling sphere has rotational as well as translational kinetic energy.

$$\begin{aligned} \therefore \text{Kinetic energy} &= \frac{1}{2}mu^2 + \frac{1}{2}I\omega^2 \\ &= \frac{1}{2}mu^2 + \frac{1}{2}\left(\frac{2}{5}mr^2\right)\omega^2 \\ &= \frac{1}{2}mu^2 + \frac{1}{5}mu^2 = \frac{7}{10}mu^2 \quad (\because u = r\omega) \end{aligned}$$

From conservation of energy

$$\text{ie,} \quad mgh = \frac{7}{10}mu^2$$

$$\text{or} \quad h = \frac{7u^2}{10g}$$

492 **(a)**

Hollow cylinder will take more time to reach the bottom because it possess larger moment of inertia

494 **(c)**

$$\text{Moment of inertia } I = MR^2$$

$M$  = mass of object,

$R$  = distance of centre of mass from axis of rotation.

Hence, moment of inertia does not depend upon angular velocity.

495 **(d)**

Since, in the given cause  $v_{\text{CM}}$  is zero, so its linear momentum will also be zero.

496 **(b)**

Angular momentum = linear momentum  $\times$  Perpendicular distance of line of action of linear momentum from the axis of rotation =  $mv \times l$



497 **(c)**  

$$I = \frac{7}{5}MR^2 = \frac{7}{5} \times 10 \times (0.5)^2 = 3.5 \text{ kg} \cdot \text{m}^2$$

498 **(b)**  
 We know  

$$L = I\omega \quad \dots(i)$$

$$L^2 = 2KI$$

From Eq. (i)  

$$L^2 = 2K \frac{L}{\omega}$$

$$L = \frac{2K}{\omega}$$

$$L' = \frac{2\left(\frac{K}{2}\right)}{2\omega} = \frac{L}{4}$$

499 **(a)**  
 For collision between blocks A and B,  

$$e = \frac{v_B - v_A}{u_A - u_B} = \frac{v_B - v_A}{10 - 0} = \frac{v_B - v_A}{10}$$

$$\therefore v_B - v_A = 10e = 10 \times 0.5 = 5 \quad \dots (i)$$

from principle of momentum conservation,  

$$m_A u_A + m_B u_B = m_A v_A + m_B v_B$$
 Or  $m \times 10 + 0 = m v_A + m v_B$   

$$\therefore v_A + v_B = 10 \quad \dots (ii)$$

Adding Eqs. (i) and (ii), we get  

$$v_B = 7.5 \text{ ms}^{-1} \quad \dots (iii)$$

Similarly for collision between B and C  

$$v_C - v_B = 7.5e = 7.5 \times 0.5 = 3.75$$

$$\therefore v_C - v_B = 3.75 \text{ ms}^{-1} \quad \dots (iv)$$

Adding Eqs. (iii) and (iv) we get  

$$2v_C = 11.25$$

$$\therefore v_C = \frac{11.25}{2} = 5.6 \text{ ms}^{-1}$$

500 **(c)**  
 Momentum of 6 kg piece  $p_2 =$  momentum of 3 kg piece  

$$p_1 = m_1 v_1 = 3 \times 16 = 48 \text{ kg ms}^{-1}$$
 Kinetic energy of 6 kg piece  $K_2 = \frac{p_2^2}{2m_2} = \frac{4 \times 48}{2 \times 8} = 192 \text{ J}.$

501 **(b)**  
 Time of descent  $\propto \frac{K^2}{R^2}$   
 Order of value of  $\frac{K^2}{R^2}$ , sphere < Disc < Ring  
 (0.4) (0.5) (1.0)

It means sphere will reach the ground first and at last ring will reach the bottom

502 **(b)**  
 Here,  $m = 0.08 \text{ kg}$   
 $m_0 = 0.16 \text{ kg}$   
 According to conservation principle of momentum  

$$m v_1 + m v_2 = (2m + m_0) v_{CM}$$



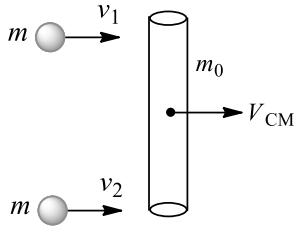

$$\begin{aligned} \therefore v_{CM} &= \frac{mv_1 + mv_2}{2m + m_0} \\ &= \frac{0.08 \times 16}{0.16 + 0.16} = \frac{1.28}{1.32} \\ &= \frac{128}{32} = 4\text{ms}^{-1} \end{aligned}$$

503 **(c)**

From law of conservation of angular momentum,

$$J = I\omega = \text{constant}$$

$$\therefore I_1\omega_1 = I_2\omega_2$$

where  $I$  is moment of inertia and  $\omega$  the angular velocity.

Moment of inertia of earth assuming it be a sphere of radius

$$R = \frac{2}{5} MR^2$$

$$\text{Also } \omega = \frac{2\pi}{T}$$

$$\therefore \left(\frac{2}{5}MR_1^2\right)\left(\frac{2\pi}{T_1}\right) = \left(\frac{2}{5}MR_2^2\right)\left(\frac{2\pi}{T_2}\right)$$

$$\Rightarrow \frac{R_1^2}{T_1} = \frac{R_2^2}{T_2}$$

$$\Rightarrow \frac{R_1^2}{24} = \left(\frac{R_1}{2}\right)^2 \times \frac{1}{T_2}$$

$$\Rightarrow T_2 = 6h$$

504 **(d)**

$$Mv = \frac{M}{4}v_1 + \frac{3}{4}Mv_2$$

$$Mv = \frac{3}{4}Mv_2 \quad (\because v_1 = 0)$$

$$v_2 = \frac{4v}{3}$$

505 **(b)**

If external force is non-zero then acceleration of centre of mass must be non-zero ( $a_0 = \frac{F_{\text{ext}}}{M} \neq 0$ ).

However, at a particular instant of time velocity of centre of mass may be zero or non-zero. Hence option (b) is correct.

506 **(a)**

$$\text{M.I. of ring about diameter } I = \frac{MR^2}{2} \quad \dots(i)$$

$$\because L = \pi R \therefore R = L/\pi$$

$$\text{From equation (i), } I = \frac{ML^2}{2\pi^2}$$

507 **(c)**

The velocity of the top point of the wheel is twice that of centre of mass and the speed of centre of mass is same for both the wheels (Angular speeds are different)

508 **(a)**

Let  $\omega$  be the angular velocity of the rod. Applying ,



Angular impulse = change in angular momentum about centre of mass of the system

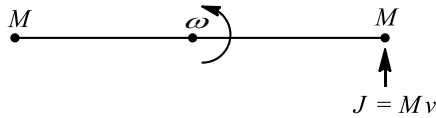

$$J \cdot \frac{L}{2} = I_c \omega$$

$$\therefore (Mv) \left(\frac{L}{2}\right) = (2) \left(\frac{ML^2}{4}\right) \cdot \omega$$

$$\therefore \omega = \frac{v}{L}$$

509 (a)

When a body rolls down without slipping along an inclined plane of inclination  $\theta$ , it rotates about a horizontal axis through its centre of mass and also its centre of mass moves. Therefore, rolling motion may be regarded as a rotational motion about an axis through its centre of mass plus a translational motion of the centre of mass. As it rolls down, it suffers loss in gravitational potential energy provided translational energy due to frictional force is converted into rotational energy.

510 (a)

If no external torque acts on a system of particle then angular momentum of the system remains constant, that is,

$$\tau = 0$$

$$\Rightarrow \frac{dL}{dt} = 0$$

$$\Rightarrow L = I\omega = \text{constant}$$

$$\Rightarrow I_1 \omega_1 = I_2 \omega_2$$

$$\therefore \frac{1}{2} Mr^2 \omega_1 = \frac{1}{2} (M + 2m)r^2 \omega_2 \quad \dots(i)$$

Here,  $M = 2\text{kg}$ ,  $m = 0.25\text{ kg}$ ,  $r = 0.2\text{m}$ .

$$\omega_1 = 30 \text{ rads}^{-1}$$

Hence, we get after putting the given values in Eq. (i)

$$\frac{1}{2} \times 2 \times (0.2)^2 \times 30 = \frac{1}{2} \times (2 + 2 \times 0.25)(0.2)^2 \times \omega_2$$

$$\Rightarrow 60 = 2.5\omega_2$$

$$\therefore \omega_2 = 24 \text{ rads}^{-1}$$

511 (d)

Applying conservation of angular momentum about point  $O$ ,

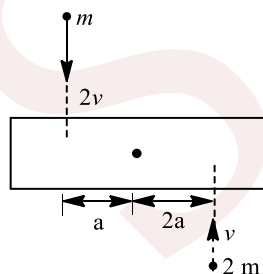

$$m(a)(2v) + 2m(2a)(v) = I\omega$$

$$\text{or } \omega = \frac{6mav}{I} \quad \dots(i)$$

Now,

$$I = \frac{6m(8a)^2}{12} + m(a)^2 + 2m(2a)^2$$

$$= 32ma^2 + ma^2 + 8ma^2 = 41ma^2$$

Hence, from Eq.(i)



$$\omega = \frac{6mav}{41ma^2} = \frac{6v}{41a}$$

512 (d)

Angle turned by the body

$$\theta = \theta_0 + \theta_1 t + \theta_2 t^2$$

$$\begin{aligned} \text{Angular velocity } \omega &= \frac{d\theta}{dt} \\ &= \frac{d}{dt} (\theta_0 + \theta_1 t + \theta_2 t) \\ &= \theta_1 + 2\theta_2 t \end{aligned}$$

$$\begin{aligned} \text{Angular acceleration } \alpha &= \frac{d\omega}{dt} \\ &= \frac{d}{dt} (\theta_1 + 2\theta_2 t) \\ &= 2\theta_2 \end{aligned}$$

513 (b)

$$\text{Initial position of centre of mass } r_{cm} = \frac{m_1 x_1 + m_2 x_2}{m_1 + m_2} \dots (i)$$

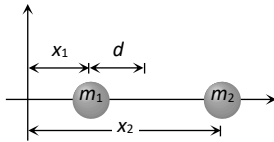

If the particles of mass  $m_1$  is pushed towards the centre of mass of the system through distance  $d$  and to keep the centre of mass at the original position let second particle be displaced through distance  $d'$  away from the centre of mass

$$\text{Now } r_{cm} = \frac{m_1(x_1+d) + m_2(x_2+d')}{m_1 + m_2} \dots (ii)$$

Equating (i) and (ii)

$$\frac{m_1 x_1 + m_2 x_2}{m_1 + m_2} = \frac{m_1(x_1 + d) + m_2(x_2 + d')}{m_1 + m_2}$$

$$\text{By solving } d' = -\frac{m_1}{m_2} d$$

Negative sign shows that particle  $m_2$  should be displaced towards the centre of mass of the system

514 (c)

Here  $\theta = 60^\circ, l = 10 \text{ m}, a = ?$

$$a = \frac{g \sin \theta}{1 + K^2/R^2}$$

For solid sphere  $K^2 = \frac{2}{5} R^2$

$$a = \frac{9.8 \sin 60^\circ}{1 + \frac{2}{5}} = \frac{5}{7} \times 9.8 \times \frac{\sqrt{3}}{2} = 6.00 \text{ ms}^{-2}$$

515 (b)

The  $(x, y, z)$  coordinates of masses  $1g, 2g, 3g$  and  $4g$  are

$$(x_1 = 0, y_1 = 0, z_1 = 0), (x_2 = 0, y_2 = 0, z_2 = 0),$$

$$(x_3 = 0, y_3 = 0, z_3 = 0),$$

$$(x_4 = \alpha, y_4 = 2\alpha, z_4 = 3\alpha)$$

$$\therefore X_{CM} = \frac{m_1 x_1 + m_2 x_2 + m_3 x_3 + m_4 x_4}{m_1 + m_2 + m_3 + m_4}$$

$$X_{CM} = \frac{1 \times 0 + 2 \times 0 + 3 \times 0 + 4 \times \alpha}{1 + 2 + 3 + 4}$$

$$1 = \frac{4\alpha}{10} \text{ or } \alpha = \frac{5}{2}$$

The value of  $\alpha$  can also be calculated by  $Y_{CM}$  and  $Z_{CM}$  as shown below



$$Y_{CM} = \frac{1 \times 0 + 2 \times 0 + 3 \times 0 + 4 \times 2\alpha}{1 + 2 + 3 + 4}$$

$$2 = \frac{8\alpha}{10} \text{ or } \alpha = \frac{20}{8} = \frac{5}{2}$$

$$Z_{CM} = \frac{1 \times 0 + 2 \times 0 + 3 \times 0 + 4 \times 3\alpha}{1 + 2 + 3 + 4}$$

$$3 = \frac{12\alpha}{10} \text{ or } \alpha = \frac{30}{12} = \frac{5}{2}$$

516

(a)

For the calculation of the position of centre of mass, cut off mass is taken as negative. The mass of disc is

$$m_1 = \pi r_1^2 \sigma$$

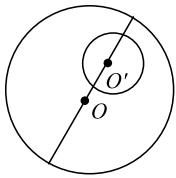

$$= \pi(6)^2 \sigma = 36\pi\sigma$$

Where  $\sigma$  is surface mass density

The mass of cutting portion is

$$m_2 = \pi(1)^2 \sigma = \pi\sigma$$

$$x_{CM} = \frac{m_1 x_1 - m_2 x_2}{m_1 - m_2}$$

Taking origin at the centre of disc,

$$x_1 = 0, x_2 = 3 \text{ cm}$$

$$x_{CM} = \frac{36\pi\sigma \times 0 - \pi\sigma \times 3}{36\pi\sigma - \pi\sigma} = \frac{-3\pi\sigma}{35\pi\sigma} = -\frac{3}{35} \text{ cm}$$

517

(b)

$$m_1 v = (m_1 + m_2) v/3$$

$$3m_1 v = m_1 v + m_2 v$$

$$3m_1 v - m_1 v = m_2 v$$

$$2m_1 v = m_2 v$$

$$\therefore \frac{m_2}{m_1} = 2$$

518

(b)

Since there is no external torque, angular momentum will remain conserved. The moment of inertia will first decrease till the tortoise moves from A to C and then increase as it moves from C to D.

Therefore  $\omega$  will initially increase and then decrease

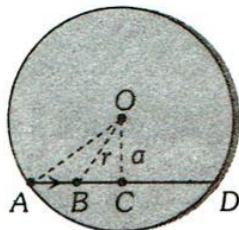

Let  $R$  be the radius of platform  $m$  the mass of tortoise and  $M$  is the mass of platform

Moment of inertia when the tortoise is at A

$$I_1 = mR^2 + \frac{MR^2}{2}$$

and moment of inertia when the tortoise is at B



$$I_2 = mr^2 + \frac{MR^2}{2}$$

$$\text{Here } r^2 = a^2 + [\sqrt{R^2 - a^2} - vt]^2$$

From conservation of angular momentum  $\omega_0 I_1 = \omega_{(t)} I_2$

Substituting the values we can find that the variation of  $\omega_{(t)}$  is non linear

519 **(c)**

$$E = \frac{L^2}{2I} \Rightarrow L = \sqrt{2EI}$$

520 **(c)**

Distance between the centre of spheres =  $12R$

$$\therefore \text{Distance between their surfaces} = 12R - (2R + R) = 9R$$

Since there is no external force, hence centre of mass must remain unchanged and hence

$$\Rightarrow m_1 r_1 = m_2 r_2 \Rightarrow Mx = 5M(9R - x) \Rightarrow x = 7.5R$$

521 **(d)**

Work done by retarding force = change in kinetic energy

$$-fs = 0 - \frac{1}{2}mv^2$$

$$\therefore fs = \frac{1}{2}mv^2$$

Since, retarding force  $f$  and kinetic energy of both bodies are same so, stopping distance will be same.

Hence, (a) is correct.

$$a = \frac{f}{m}$$

$$\therefore v^2 = u^2 - 2as$$

$$\text{Or } 0 = u^2 - 2as$$

$$\therefore u^2 = 2as = \frac{2sf}{m}$$

$$\therefore u \propto \frac{1}{\sqrt{3}}$$

It means more is the mass, less is the initial speed

$$\therefore v = u - at$$

$$\text{Or } 0 = u - at$$

$$\therefore t = \frac{u}{a} = \frac{u}{\frac{f}{m}} = \frac{um}{f}$$

$$\therefore t \propto m$$

Hence, more is the mass, less is the time of stopping. Hence, (b) is correct

$$\therefore KE = K = \frac{p^2}{2m}$$

$$\therefore p^2 \propto m$$

It means more is the mass, more is the momentum

Hence, (c) is correct.

523 **(d)**

Let the mass of loop  $P$  (radius =  $r$ ) =  $m$

So the mass of loop  $Q$  (radius =  $nr$ ) =  $nm$



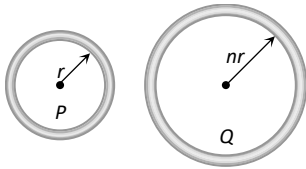

Moment of inertia of loop P,  $I_P = mr^2$

Moment of inertia of loop Q,  $I_Q = nm(nr)^2 = n^3mr^2$

$$\therefore \frac{I_Q}{I_P} = n^3 = 8 \Rightarrow n = 2$$

524 (a)

$$15m + 10m = mv_1 + mv_2$$

$$25 = v_1 + v_2$$

$$\text{And } \frac{v_2 - v_1}{u_1 - u_2} = 1$$

$$\Rightarrow \frac{v_2 - v_1}{15 - 10} = 1$$

$$\Rightarrow v_2 - v_1 = 5$$

Solving Eqs. (i) and (ii), we have

$$v_2 = 15\text{ms}^{-1}, v_1 = 10\text{ms}^{-1}$$

525 (c)

$$\omega^2 = \omega_0^2 - 2\alpha\theta \Rightarrow 0 = 4\pi^2n^2 - 2\alpha\theta$$

$$\theta = \frac{4\pi^2 \left(\frac{1200}{60}\right)^2}{2 \times 4} = 200\pi^2 \text{rad}$$

$$\therefore 2\pi n = 200\pi^2 \Rightarrow n = 100\pi = 314 \text{ revolution}$$

526 (a)

$$\text{M.I. of rod (1) about } Z\text{-axis, } I_1 = \frac{Ml^2}{3}$$

$$\text{M.I. of rod (2) about } Z\text{-axis, } I_2 = \frac{Ml^2}{3}$$

$$\text{M.I. of rod (3) about } Z\text{-axis, } I_3 = 0$$

Because this rod lies on Z-axis

$$\therefore I_{\text{system}} = I_1 + I_2 + I_3 = \frac{2Ml^2}{3}$$

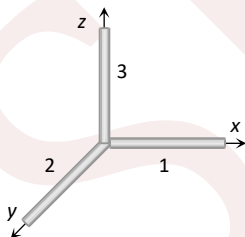

527 (c)

$$I = MR^2 \therefore \log I = \log M + 2 \log R$$

$$\text{Differentiating, we get } \frac{dI}{I} = 0 + 2 \frac{dR}{R}$$

$$\therefore \frac{dI}{I} \times 100 = 2 \left(\frac{dR}{R}\right) \times 100$$

$$= 2 \times \frac{1}{100} \times 100 = 2\%$$

528 (a)

Linear momentum  $p$  and kinetic energy  $K$  are interrelated as



$K = \frac{p^2}{2m}$  or  $p = \sqrt{2mK}$ , hence zero momentum implies zero kinetic energy and *vice versa*.

529

(b)

Angular momentum about rotational axis

$$L_t = [I + m(vt)^2]\omega$$

$$\frac{dL_t}{dt} = 2mv^2t\omega;$$

$$\text{Torque } \tau = (2mv^2\omega)t$$

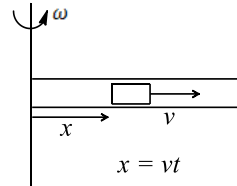

530

(d)

Moment of inertia of the cylinder about an axis perpendicular to the axis of the cylinder and passing through the centre is

$$I = M \left( \frac{R^2}{4} + \frac{L^2}{12} \right) \dots(i)$$

If  $\rho$  is volume density of the cylinder, then

$$M = (\pi R^2 L)\rho = \text{constant} \dots(ii)$$

$$\therefore L = \frac{M}{\pi R^2 \rho}$$

Put in Eq. (i),

$$I = M \left( \frac{R^2}{4} + \frac{M^2}{12\pi^2 R^4 \rho^4} \right)$$

For  $I$  to be minimum,  $\frac{\partial I}{\partial R} = 0$

$$\frac{\partial I}{\partial R} = M \left( \frac{R}{2} - \frac{M^2}{3\pi^2 R^5} \right) = 0$$

$$\frac{R}{2} = \frac{M^2}{3\pi^2 \rho^2 R^5} \text{ or } R^6 = \frac{2M^2}{3\pi^2 \rho^2}$$

$$\text{Using Eq. (ii), } R^6 = \frac{2\pi^2 R^4 L^2 \rho^2}{3\pi^2 \rho^2}$$

$$\text{or } R^2 = \frac{2}{3}L^2 \text{ or } \frac{L^2}{R^2} = \frac{3}{2}$$

$$\text{or } \frac{L}{R} = \sqrt{3/2}$$

531

(b)

Angular of the body is given by

$$L = I\omega$$

$$\text{or } L = I \times \frac{2\pi}{T} \text{ or } L \propto \frac{1}{T}$$

$$\Rightarrow \frac{L_1}{L_2} = \frac{T_2}{T_1}$$

$$\frac{L}{L_2} = \frac{2T}{T}$$

$$(As, T_2 = 2T)$$

$$\text{So, } L_2 = \frac{L}{2}$$

Thus, on doubling the time period, angular momentum of body becomes half.

532

(a)



$$\omega_1 = \frac{900}{60} \times 2\pi = 30\pi \text{ rad/s}, \omega_f = 0, t = 60\text{s}$$

$$\omega_f = \omega_t + \alpha t \therefore \alpha = \frac{\omega_f - \omega_t}{t} = \frac{0 - 30\pi}{60} = -\frac{\pi}{2} \text{ rad/s}^2$$

533 **(b)**

A solid sphere is rotating in free space, so there is no external torque.

ie,  $\tau = 0$

But the rate of change of angular momentum is equal to the torque.

then  $\frac{dJ}{dt} = 0$

or  $dJ = 0$

or  $J = \text{constant}$

But  $J = I\omega$ , if we increase the radius of the sphere then its moment of inertia ( $I = \frac{2}{5} MR^2$ ) increases.

From  $J = I\omega$ , its angular velocity decreases.

Also we know that the rotational energy

$$K_r = \frac{J^2}{2I}$$

Hence,  $K_r$  decreases as  $I$  is increases.

534 **(b)**

The motion of the centre of mass is the result of external forces.

536 **(d)**

Torque acting on a body in circular motion is zero.

537 **(b)**

From conservation of angular momentum ( $I\omega = \text{constant}$ ), angular velocity will remain half. As,

$$K = \frac{1}{2} I\omega^2$$

The rotational kinetic energy will become half.

538 **(a)**

$$K_N = \frac{1}{2} mv^2 \left( 1 + \frac{K^2}{R^2} \right) = \frac{1}{2} mv^2 \left( 1 + \frac{2}{5} \right) = \frac{7}{10} mv^2$$

539 **(d)**

If  $n$  masses are equal

$$m_1 = m_2 = m_3 = \dots = m_n$$

Then position vector of centre of mass.

The coordinate of the centre of mass

$$\begin{aligned} (x, y) &= \left( \frac{m_1x_1 + m_2x_2 + m_3x_3}{m_1 + m_2 + m_3}, \frac{m_1y_1 + m_2y_2 + m_3y_3}{m_1 + m_2 + m_3} \right) \\ &= \left( \frac{m + 2m + 3m}{3m}, \frac{m + 2m + 3m}{3m} \right) \\ &= \left( \frac{6m}{3m}, \frac{6m}{3m} \right) \\ &= (2, 2) \end{aligned}$$

540 **(a)**

Here,  $m_1 = 1 \text{ kg}, \vec{v}_1 = 2\hat{i}$

$m_2 = 2 \text{ kg}, \vec{v}_2 = 2 \cos 30^\circ \hat{i} - 2 \sin 30^\circ \hat{j}$

$$\begin{aligned} \vec{v}_{\text{CM}} &= \frac{m_1\vec{v}_1 + m_2\vec{v}_2}{m_1 + m_2} \\ &= \frac{1 \times 2\hat{i} + 2(2 \cos 30^\circ \hat{i} - 2 \sin 30^\circ \hat{j})}{1 + 2} \end{aligned}$$



$$= \frac{2\hat{i} + 2\sqrt{3}\hat{j} - 2\hat{j}}{3} = \left(\frac{2 + 2\sqrt{3}}{3}\right)\hat{i} - \frac{2}{3}\hat{j}$$

541 (b)

$E = \frac{L^2}{2I}$ . If boy stretches his arm then moment of inertia increases and accordingly kinetic energy of the system decreases because  $L = \text{constant}$  and  $E \propto \frac{1}{I}$

542 (b)

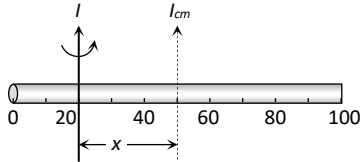

$$I = I_{cm} + mx^2 = \frac{ml^2}{12} + mx^2 = m\left(\frac{(1)^2}{12} + (0.3)^2\right)$$

$$= 0.6\left(\frac{1}{12} + 0.09\right) = 0.104 \text{ kg} - m^2$$

543 (b)

$$n_1 = 20 \text{ rev/s}, n_2 = 0, t = 20s$$

$$\alpha = \frac{2\pi(n_2 - n_1)}{t} = -\frac{2\pi \times 20}{20} = -2\pi \text{ rad/s}^2$$

544 (b)

According to theorem of parallel axes, moment of inertia of a rod about one of its ends

$$= \frac{Ml^2}{12} + \frac{Ml^2}{4} = \frac{Ml^2}{3}$$

$\therefore$  Moment of inertia of two rods about Z-axis = Moment of inertia of 2 rods placed along X and Y-axis

$$= \frac{2Ml^2}{3}$$

546 (d)

We know that velocity of 2nd ball after collision is given by

$$v_2 = \frac{u_1(1+e)m_1}{(m_1+m_2)} + u_2 \frac{(m_2-m_1)e}{(m_1+m_2)}$$

In present problem  $u_2 = 0, m_2 = 2m_1$  and  $e = 2/3$ , hence

$$v_2 = \frac{u\left(1 + \frac{2}{3}\right)m_1}{(m_1 + 2m_1)} = \frac{5}{9}u$$

As four exactly similar type of collisions are taking place successively, hence velocity communicated to fifth ball

$$v_5 = \left(\frac{5}{9}\right)^4 u$$

548 (c)

As per conservation law of momentum  $0 = 4v + (A - 4)v_r$

$$\therefore \text{Recoil speed } v_r = \frac{4v}{(A-4)}$$

549 (d)

When C collides with B then due to impulsive force, combined mass (B + C) starts to move upward. Consequently the string becomes slack

550 (d)

As there is no net external force, hence motion of centre of mass of fragments should have been as before.



- 551 **(b)**  
 $r_1 = 0, r_2 = PQ, r_3 = PR$   
 Distance of centre of mass from  $P$  is  

$$r = \frac{r_1 + r_2 + r_3}{3} = \frac{0 + PQ + PR}{3} = \frac{PQ + PR}{3}$$
- 553 **(c)**  

$$F = \frac{\Delta p}{\Delta t} = v \frac{\Delta m}{\Delta t} = v \frac{nm}{t}$$

$$F = vm \frac{n}{60} = \frac{mvn}{60}$$
- 554 **(a)**  
 Since  $\omega$  is constant,  $v$  would also be constant, so, no net force or torque is acting on ring. The force experienced by any particle is only along radial direction, or we can say the centripetal force  
**Dd**  
 The force experienced by inner part  $F_1 = m\omega^2 R_1$  and the force experienced by outer part,  $F_2 = m\omega^2 R_2$   

$$\therefore \frac{F_1}{F_2} = \frac{mR_1\omega^2}{mR_2\omega^2} = \frac{R_1}{R_2}$$
- 555 **(d)**  
 Moment of inertia of system about  $YY'$   

$$I = I_1 + I_2 + I_3$$

$$= \frac{1}{2}MR^2 + \frac{3}{2}MR^2 + \frac{3}{2}MR^2$$

$$= \frac{7}{2}MR^2$$
- 
- 556 **(a)**  
 As we know that at the highest point, the shell has only the horizontal component of velocity which is  $v \cos \theta$ . If  $u$  be the velocity of second exploded piece, then applying conservation of linear momentum along  $x$ -axis  

$$\therefore 2mv \cos \theta = -mv \cos \theta + mu$$
  
 Or  $u = 3v \cos \theta$
- 557 **(b)**  
 We assume that origin is situated at the  $O_1$   

$$\therefore x_1 = 0, m_1 = m,$$

$$x_2 = 3a, m_2 = 2m$$

$$\therefore x_{CM} = \frac{m_1 x_1 + m_2 x_2}{m_1 + m_2}$$

$$= \frac{m \times 0 + 2m \times 3a}{m + 2m}$$

$$= \frac{6ma}{3m} = 2a$$
- 558 **(b)**



Kinetic energy will not be conserved because friction force is acting at the point of contact with the plane. But torque of this force about point of contact will be zero. So angular momentum of the sphere about point of contact will be conserved

$$\vec{\tau} = \frac{d\vec{L}}{dt}, \text{ if } \vec{\tau} = 0 \text{ then } \vec{L} = \text{constant}$$

559

(c)

According to problem disc is melted and recasted into a solid sphere so their volume will be same

$$V_{\text{Disc}} = V_{\text{Sphere}} \Rightarrow \pi R_{\text{Disc}}^2 t = \frac{4}{3} \pi R_{\text{Sphere}}^3$$

$$\Rightarrow \pi R_{\text{Disc}}^2 \left(\frac{R_{\text{Disc}}}{6}\right) = \frac{4}{3} \pi R_{\text{Sphere}}^3 \quad \left[t = \frac{R_{\text{Disc}}}{6}, \text{ given}\right]$$

$$\Rightarrow R_{\text{Disc}}^3 = 8R_{\text{Sphere}}^3 \Rightarrow R_{\text{Sphere}} = \frac{R_{\text{Disc}}}{2}$$

$$\text{Moment of inertia of disc } I_{\text{Disc}} = \frac{1}{2} MR_{\text{Disc}}^2 = I \text{ [Given]}$$

$$\therefore M(R_{\text{Disc}})^2 = 2I$$

$$\text{Moment of inertia of sphere } I_{\text{Sphere}} = \frac{2}{5} MR_{\text{Sphere}}^2$$

$$= \frac{2}{5} M \left(\frac{R_{\text{Disc}}}{2}\right)^2 = \frac{M}{10} (R_{\text{Disc}})^2 = \frac{2I}{10} = \frac{I}{5}$$

560

(d)

$$\text{M.I. of disc} = \frac{1}{2} mR^2 = \frac{1}{2} (\pi R^2 t) \rho R^2 = \frac{1}{2} \pi R^4 t \rho \quad [\rho = \text{density}, t = \text{thickness}]$$

If discs are made of same material and same thickness then  $I \propto R^4 \propto (\text{Diameter})^4$

$$\therefore \frac{I_A}{I_B} = \left(\frac{D_A}{D_B}\right)^4 = \left(\frac{2}{1}\right)^4 = \frac{16}{1}$$

561

(b)

Let the each side of square lamina is  $d$ .

$$\text{So, } I_{EF} = I_{GH} \quad (\text{due to symmetry})$$

$$\text{And } I_{AC} = I_{BD} \quad (\text{due to symmetry})$$

Now, according to theorem of perpendicular axis,

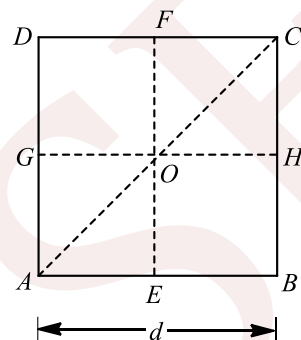

$$I_{AC} + I_{BD} = I_0$$

$$\Rightarrow 2I_{AC} = I_0 \quad \dots(i)$$

$$\text{and } I_{EF} + I_{GH} = I_0$$

$$\Rightarrow 2I_{EF} = I_0 \quad \dots(ii)$$

From Eqs. (i) and (ii), we get

$$I_{AC} = I_{EF}$$

$$\therefore I_{AD} = I_{EF} + \frac{md^2}{4}$$

$$= \frac{md^2}{12} + \frac{md^2}{4} \quad \left(\text{as } I_{EF} = \frac{md^2}{12}\right)$$



So,  $I_{AD} = \frac{md^2}{3} = 4I_{EF}$

- 563 **(d)**  
As shown in figure, centre of mass of respective rods are at their respective mid points. Hence centre of mass of the system has coordinates  $(X_{CM}, Y_{CM})$ . then

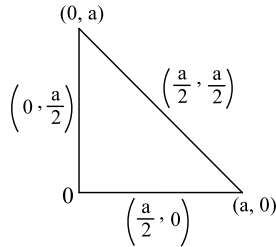

$$X_{CM} = \frac{m \times \frac{a}{2} + m \times \frac{a}{2} + m \times 0}{3m} = \frac{a}{3}$$

$$Y_{CM} = \frac{m \times 0 + m \times \frac{a}{2} + m \times 0}{3m} = \frac{a}{3}$$

- 564 **(c)**  
The kinetic energy of the solid sphere,

$$K = \frac{1}{2} Mv^2 \quad \dots(i)$$

The rotational kinetic energy,

$$K_r = \frac{1}{2} I\omega^2$$

But  $I = \frac{2}{5} MR^2$  for solid sphere and  $\omega = \frac{v}{R}$

then,  $K_r = \frac{1}{2} \times \frac{2}{5} MR^2 \times \frac{v^2}{R^2}$   
 $K_r = \frac{1}{5} Mv^2 \quad \dots(ii)$

On dividing Eq. (ii) by Eq. (i), we have

$$\frac{K_r}{K} = \frac{1/5 Mv^2}{1/2 Mv^2}$$

or  $\frac{K_r}{K} = \frac{2}{5}$

- 565 **(b)**  
 $\theta = \omega_0 t + \frac{1}{2} \alpha t^2 \Rightarrow \theta = 100 \text{ rad}$   
 $\therefore$  Number of revolution =  $\frac{100}{2\pi} = 16$  (approx.)

- 566 **(b)**  
From conservation law of momentum

$$\frac{v_1}{v_2} = \frac{2}{1} = \frac{m_2}{m_1} = \frac{\frac{4}{3} \pi r_2^3 \rho}{\frac{4}{3} \pi r_1^3 \rho} = \left(\frac{r_2}{r_1}\right)^3$$

$$\Rightarrow \frac{r_2}{r_1} = (2)^{1/3} : 1$$

Or  $r_1 : r_2 = 1 : (2)^{1/3}$

- 567 **(b)**  
Given,  $I = 1 \text{ kg} - \text{m}^2, n = 2 \text{ rps}$   
 $\omega = 2\pi n = 2\pi \times 2 = 4\pi \text{ rads}^{-1}$   
 $L = I\omega = 1(4\pi) = 12.57 \text{ kg} - \text{m}^2 \text{s}^{-1}$

- 568 **(c)**  
In rotational motion of a rigid body, the centre of mass of the body moves uniformly in a circular path.



- 569 **(b)**  
A raw egg behaves like a spherical shell and a half boiled egg behaves like a solid sphere  

$$\therefore \frac{I_r}{I_s} = \frac{2/3 mr^2}{2/5 mr^2} = \frac{5}{3} > 1$$
- 570 **(a)**  
Velocity of bullet at highest point of its trajectory =  $50 \cos \theta$  in horizontal direction.  
As bullet of mass  $m$  collides with pendulum bob of mass  $3m$  and two stick together, their common velocity  

$$v' = \frac{m_1 50 \cos \theta}{m + 3m} = \frac{25}{2} \cos \theta \text{ ms}^{-1}$$
  
As now under this velocity  $v'$  pendulum bob goes up to an angle  $120^\circ$ , hence  

$$\frac{v'^2}{2g} = h = l(1 - \cos 120^\circ) = \frac{10}{3} \left[ 1 - \left( -\frac{1}{2} \right) \right] = 5$$
  

$$\Rightarrow v'^2 = 2 \times 10 \times 5 = 100 \text{ or } v' = 10$$
  
Comparing two answer of  $v'$ , we get  

$$\frac{25}{2} \cos \theta = 10 \Rightarrow \cos \theta = \frac{4}{5} \text{ or } \theta = \cos^{-1} \left( \frac{4}{5} \right)$$
- 571 **(c)**  
From law of conservation of angular momentum we have, if no external torque is acting on a body ( $\tau = 0$ ), then the angular momentum ( $J = I\omega$ ) or in other words the moment of momentum of a body remains constant.
- 572 **(d)**  
No of revolution = Area of trapezium  

$$= \frac{1}{2} \times (2.5 + 5) \times 3000 = 11250 \text{ rev}$$
- 573 **(d)**  
External force acting on the system is given as  

$$\mathbf{F}_{\text{ext}} = M \mathbf{a}_{\text{CM}}$$
  
ie,  $\mathbf{a}_{\text{CM}}$  lies in the direction of  $\mathbf{F}_{\text{ext}}$ .  
Here,  $\mathbf{F}_{\text{ext}} = 5(2\hat{i} + 3\hat{j} - 5\hat{k})$   

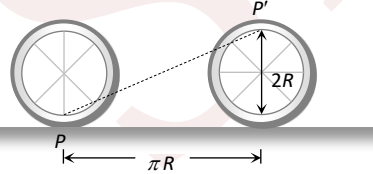
$$\mathbf{a}_{\text{CM}} = 2\hat{i} + 3\hat{j} - 5\hat{k}$$
  
Since,  $\mathbf{F}_{\text{ext}}$  and  $\mathbf{a}_{\text{CM}}$  are not lying in the same direction, given data is incorrect.
- 574 **(d)**  
Total moment of inertia of the system =  $\frac{1}{2}MR^2 + 4mR^2$
- 575 **(d)**
- 
- Displacement of point  $P$  after half revolution  

$$PP' = \sqrt{(\pi R)^2 + (2R)^2} = R\sqrt{\pi^2 + 4} = 5\sqrt{\pi^2 + 4}$$
- 577 **(c)**  
Moment of inertia of whole disc about an axis through centre of disc and perpendicular to its plane is  

$$I = \frac{1}{2}mr^2$$
  
As one quarter of disc is removed, new mass,



$$m' = \frac{3}{4}m$$

$$\therefore I' = \frac{1}{2} \left( \frac{3}{4}m \right) r^2 = \frac{3}{8}mr^2$$

578 **(b)**

When pulley has a finite mass  $M$  and radius  $R$ , then tension in two segments of string are different.

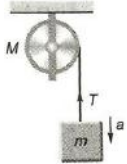

Here,  $ma = mg - T$

$$a = \frac{m}{m + \frac{M}{2}}g = \frac{2m}{2m + M}g$$

581 **(a)**

$$I_{\text{remaining}} = I_{\text{whole}} - I_{\text{removed}}$$

$$\text{or } I = \frac{1}{2}(9M)(R^2) - \left[ \frac{1}{2}m \left( \frac{R}{3} \right)^2 + \frac{1}{2}m \left( \frac{2R}{3} \right)^2 \right] \quad \dots(i)$$

$$\text{Here, } m = \frac{9M}{\pi R^2} \times \pi \left( \frac{R}{3} \right)^2 = M$$

Substituting in Eq. (i), we have

$$I = 4MR^2$$

582 **(c)**

$$I = I_x + I_y = \frac{mL^2}{12} + \frac{mL^2}{12} = \frac{mL^2}{6}$$

583 **(b)**

Centre of mass always lies towards heavier mass

585 **(c)**

At the time of applying the impulsive force block of 10 kg pushes the spring forward but 4 kg mass is at rest.

Hence,

$$v_{\text{CM}} = \frac{m_1 v_1 + m_2 v_2}{m_1 + m_2} = \frac{10 \times 14 + 4 \times 0}{10 + 4} = \frac{140}{14} = 10 \text{ms}^{-1}$$

586 **(b)**

The object will have translation motion without rotation, when force  $F$  is applied at the centre of mass of system. If  $m$  is mass per unit length, the mass of  $AB$ ,  $m_1 = ml$  at  $O$  and mass of  $OC$ ,  $m_2 = m(2l)$  at  $D$ , where  $CD = l$

Dd

Let  $DP = x$

As  $P$  is the centre of mass, therefore

$$ml(l - x) = 2mlx$$

$$3x = l: x = l/3$$

$$\therefore CP = CD + DP = l + \frac{l}{3} = \frac{4l}{3}$$

587 **(b)**

From law of conservation of energy, we have the potential energy of rod when it is vertical is converted to kinetic energy of rotation.



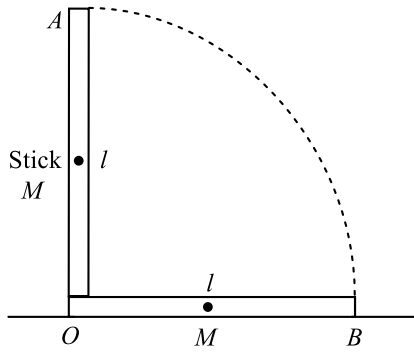

$$\therefore \frac{M}{2}gl = \frac{1}{2}I\omega^2$$

Moment of inertia of a thin rod is

$$I = \frac{1}{3}Ml^2$$

$$\frac{M}{2}gl = \frac{1}{2} \frac{Ml^2}{3} \omega^2$$

$$\Rightarrow \omega = \sqrt{\frac{3g}{l}}$$

Given,  $l = 1 \text{ m}$ ,  $\omega = \sqrt{3g}$

Also,  $v = r\omega$

$$\Rightarrow v = 1 \times \sqrt{3 \times 9.8} = 5.4 \text{ ms}^{-1}$$

588 **(a)**

From conservation of momentum

$$Mv = m \times 0 + (M - m)v' \Rightarrow v' = \frac{Mv}{(M - m)}$$

589 **(d)**

$$\omega = \frac{v}{r} = \frac{80}{20/\pi} = 4\pi, \omega_0 = 0, \theta = 2\pi(n) = 4\pi (\text{As } n = 2)$$

$$\omega^2 = \omega_0^2 + 2\alpha\theta \Rightarrow \alpha = \frac{\omega^2 - \omega_0^2}{2\theta} = \frac{16\pi^2}{2 \times 4\pi} = 2\pi$$

Tangential acceleration  $a_t = r\alpha = \frac{20}{\pi} \times 2\pi = 40 \text{ m/s}^2$

590 **(b)**

Moment of inertia of a uniform rod about one end =  $\frac{ml^2}{3}$

$\therefore$  Moment of inertia of the system

$$= 2 \times \left(\frac{M}{2}\right) \frac{(L/2)^2}{3} = \frac{ML^2}{12}$$

591 **(b)**

$$r_2 = r_4 = OA = \frac{l}{\sqrt{2}} \text{ and } r_3 = l\sqrt{2}$$

Moment of inertia of the system about given axis

$$I = I_1 + I_2 + I_3 + I_4$$



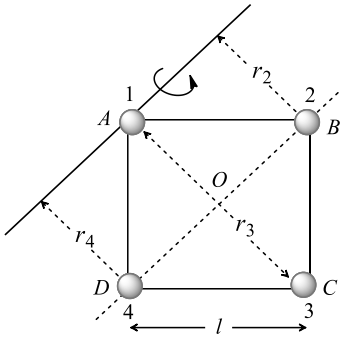

$$\Rightarrow I = 0 + m(r_2)^2 + m(r_3)^2 + m(r_4)^2$$

$$\Rightarrow I = m\left(\frac{l}{\sqrt{2}}\right)^2 + m(l\sqrt{2})^2 + m\left(\frac{l}{\sqrt{2}}\right)^2 \therefore I = 3ml^2$$

592

(c)

There is no shift in position of centre of mass, as clear from the figure

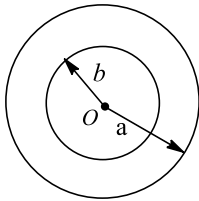

593

(b)

From the definition of angular momentum,

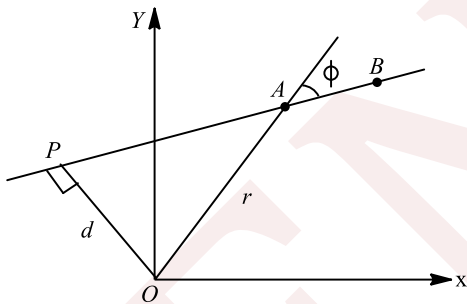

$$\mathbf{L} = \mathbf{r} \times \mathbf{p} = rmv \sin \phi (-\hat{\mathbf{k}})$$

Therefore, the magnitude of  $L$  is

$$L = mvr \sin \phi = mvd$$

where  $d = r \sin \phi$  is the distance of closest approach of the particle to the origin. As  $d$  is same for both the particles, hence  $L_A = L_B$ .

594

(b)

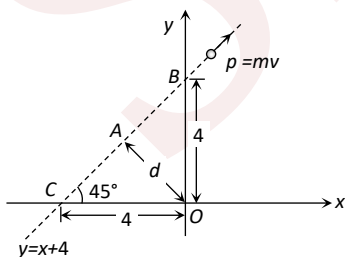

Form the triangle  $OAC$

$$d = OC \sin 45^\circ = 4 \times \frac{1}{\sqrt{2}} = 2\sqrt{2}$$

Angular momentum = Linear momentum  $\times$  Perpendicular distance of line of action of linear momentum from the point of rotation



595  $L = p \times d = mvd = 5 \times 3\sqrt{2} \times 2\sqrt{2} = 60 \text{ units}$

**(b)**

As no torque is being applied, angular momentum

$$L = l\omega = \text{constant}$$

$$\left(\frac{2}{5}Mr^2\right)\frac{2\pi}{T} = \text{constant}$$

$$\text{or } \frac{r^2}{T} = \text{constant}$$

Differentiating w.r.t time ( $t$ ), we get

$$\frac{T \cdot 2r \frac{dr}{dt} - r^2 \frac{dT}{dt}}{T^2} = 0$$

$$\text{or } 2Tr \frac{dr}{dt} = r^2 \frac{dT}{dt}$$

$$\text{or } \frac{dT}{dt} = \frac{2T}{r} \frac{dr}{dt}$$

596 **(c)**

$$x_{\text{CM}} = \frac{m_A x_A + m_B x_B + m_C x_C + m_D x_D}{m_A + m_B + m_C + m_D}$$

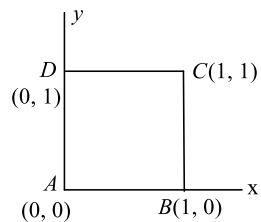

$$= \frac{1 \times 0 + 2 \times 1 + 3 \times 1 + 4 \times 0}{1 + 2 + 3 + 4}$$

$$= \frac{2+3}{10} = \frac{1}{2} = 0.5 \text{ m}$$

$$\text{Similarly, } y_{\text{CM}} = \frac{m_A y_A + m_B y_B + m_C y_C + m_D y_D}{m_A + m_B + m_C + m_D}$$

$$= \frac{1 \times 0 + 2 \times 0 + 3 \times 1 + 4 \times 1}{1 + 2 + 3 + 4}$$

$$= \frac{7}{10} = 0.7 \text{ m}$$

597 **(a)**

Moment of inertia about the given axis *ie*, about  $YY''$ ,

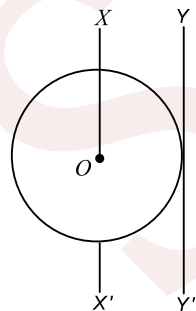

$$I_{YY'} = I_{XX'} + MR^2$$

$$= 2 + 2 \times (2)^2$$

$$= 2 + 8$$

$$= 10 \text{ kg} - \text{m}^2$$

598 **(a)**

$$I = \frac{\tau}{\alpha} = \frac{31.4}{4\pi} = 2.5 \text{ kg m}^2$$



599

(d)

The moment of inertia of the disc about an axis parallel to its plane is

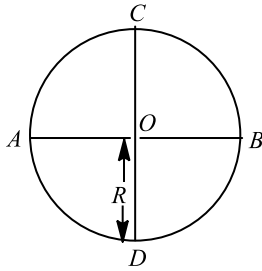

$$I_t = I_d + MR^2$$

$$\Rightarrow I = \frac{1}{4}MR^2 + MR^2$$

$$= \frac{5}{4}MR^2$$

or  $MR^2 = \frac{4I}{5}$

Now, moment of inertia about a tangent perpendicular to its plane is

$$I' = \frac{3}{2}MR^2 = \frac{3}{2} \times \frac{4}{5}I = \frac{6}{5}I$$

600

(d)

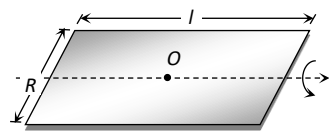

M.I. of plane about O and parallel to length =  $\frac{Mb^2}{12}$

601

(a)

For elastic collision  $e = 1$  and velocity of separation is equal to velocity of approach. The velocity of the target may be more, equal or less than that of projectile depending on their masses.

The maximum velocity of target is double to that of projectile, when projectile is extremely massive as compared to the target.

Maximum kinetic energy is transferred from projectile to target when their masses are exactly equal.

602

(a)

Here  $m_1 = u, m_2 = Au, u_1 = u$  and  $u_2 = 0$

$$\therefore v_1 = \frac{(m_1 - m_2)u_1}{(m_1 + m_2)} + \frac{2m_2u_2}{(m_1 + m_2)} = \left(\frac{1 - A}{1 + A}\right)u$$

$$\Rightarrow \frac{v_1}{u} = \left(\frac{1 - A}{1 + A}\right)$$

$$\therefore \frac{K_{\text{final}}}{K_{\text{initial}}} = \left(\frac{v_1}{u}\right)^2 = \left(\frac{1 - A}{1 + A}\right)^2$$

603

(c)

$$\omega_{\text{min}} = \frac{2\pi \text{ rad}}{60 \text{ min}}$$

and  $\omega_{\text{hr}} = \frac{2\pi \text{ rad}}{12 \times 60 \text{ min}}$

$$\therefore \frac{\omega_{\text{min}}}{\omega_{\text{hr}}} = \frac{2\pi/60}{2\pi/12 \times 60}$$

$$= \frac{12}{1}$$

604

(c)

The impact force  $F = \frac{\Delta p}{\Delta t} = v \frac{\Delta m}{\Delta t}$  where  $\frac{\Delta m}{\Delta t}$  = rate of flow of water in the nozzle and  $v$  the velocity of water jet.



Since the ball is in equilibrium  $F = mg$  where  $m =$  mass of ping pong ball.

$$\Rightarrow v \frac{\Delta m}{\Delta t} = mg \text{ or rate of flow of water } \frac{\Delta m}{\Delta t} = \frac{mg}{v}$$

605

**(d)**

Let  $M$  be the mass and  $L$  be the length of given uniform rod

Moment of inertia of the rod about one end is

$$I_1 = \frac{1}{3}ML^2 \quad \dots(i)$$

When it is bent into a ring

$$\therefore L = 2\pi R$$

$$\text{Or } R = \frac{L}{2\pi} \quad \dots(ii)$$

Moment of inertia of a ring about its diameter is

$$I_2 = \frac{MR^2}{2} = \frac{ML^2}{8\pi^2} \quad [\text{Using (ii)}]$$

$$\therefore \frac{I_1}{I_2} = \frac{ML^2}{3} \times \frac{8\pi^2}{ML^2} = \frac{8\pi^2}{3}$$

606

**(d)**

$$a = \frac{g \sin \theta}{1 + \frac{K^2}{R^2}} = \frac{g \sin \theta}{1 + \frac{2}{5}} = \frac{g/2}{7/5} = \frac{5g}{14}$$

$$\text{As } \theta = 30^\circ \text{ and } \frac{K^2}{R^2} = \frac{2}{5}$$

607

**(c)**

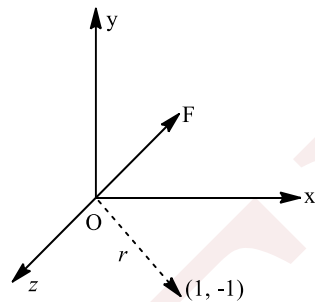

$$\tau = \mathbf{r} \times \mathbf{F}$$

$$\begin{aligned} \tau &= (\hat{i} - \hat{j}) \times (-F \hat{k}) \\ &= F[(-\hat{i} \times \hat{k}) + (\hat{j} \times \hat{k})] \\ &= F[\hat{i} + \hat{j}] \end{aligned}$$

608

**(d)**

$$L = I\omega$$

609

**(a)**

Since disc is rolling (without slipping) about point  $O$

Hence

$$OQ > OC > OP$$

$$\therefore v = r\omega$$

$$\therefore v_Q > v_C > v_P$$

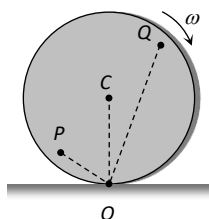

- 610 **(d)**  
Angular momentum  $L$  is given as  

$$L = \vec{r} \times \vec{p} = rp \sin \theta$$
 $\vec{r}$  = position vector of the particle w. r. t. origin,  
 $\vec{p}$  = its linear momentum  
 $\vec{r} \times \vec{p}$  is maximum when  $p$  is perpendicular to  $r$   
*i. e.*  $\theta = 90^\circ$
- 611 **(d)**  
Angular velocity is a axial vector
- 612 **(d)**  
As the inclined plane is frictionless therefore all the bodies will slide down along the inclined plane with same acceleration  $g \sin \theta$
- 613 **(b)**  
In pure rolling, mechanical energy remains conserved. Therefore, when heights of inclines are equal, speed of sphere will be same in both the cases. But as acceleration down the plane,  $a \propto \sin \theta$  therefore, acceleration and time of descent will be different
- 614 **(d)**  
For a disc moment of inertia about a tangential axis in its own plane  $= \frac{5}{4} MR^2$   
 $\therefore M_1 K_1^2 = \frac{5}{4} M_1 R^2$   
 $\Rightarrow K_1 = \frac{\sqrt{5}}{2} R$   
 Now, for a ring moment of inertia about a tangential axis in its own plane  $= \frac{3}{2} M_2 R^2$   
 $\therefore M_2 K_2^2 = \frac{3}{2} M_2 R^2$   
 $\Rightarrow K_2 = \sqrt{\frac{3}{2}} R$   
 $\therefore \frac{K_1}{K_2} = \frac{\sqrt{5}}{\sqrt{6}}$
- 615 **(d)**  
If  $M$  mass of the square plate before cutting the holes, then mass of portion of each hole,  

$$m = \frac{M}{16R^2} \times \pi R^2 = \frac{\pi}{16} M$$
 $\therefore$  Moment of inertia of remaining portion  

$$I = I_{\text{square}} - 4I_{\text{hole}}$$

$$= \frac{M}{12} (16R^2 + 16R^2) - 4 \left[ \frac{mR^2}{2} + m(\sqrt{2}R)^2 \right]$$

$$= \frac{M}{12} \times 32R^2 - 10mR^2$$

$$= \frac{8}{3} MR^2 - \frac{10\pi}{16} MR^2 \quad I = \left( \frac{8}{3} - \frac{10\pi}{16} \right) MR^2$$
- 616 **(c)**  

$$F = v \frac{\Delta m}{\Delta t}$$
 Here,  $\frac{\Delta m}{\Delta t} = \frac{nm}{t} = \frac{120 \times 10 \times 10^{-3}}{60} = 20 \times 10^{-3} \text{ kg s}^{-1}$   
 $\therefore F = 800 \times 20 \times 10^{-3} \text{ N} = 16 \text{ N}$
- 617 **(c)**



Let distance of man from the floor be  $(10 + x)m$ . As centre of mass of system remains at  $10m$  above the floor

$$\text{So } 50(x) = 0.5(10) \Rightarrow x = 0.1m$$

$$\Rightarrow \text{distance of the man above the floor} = 10 + 0.1 = 10.1m$$

618 (d)

$$\text{Centripetal force } F = \frac{mv^2}{r} = \frac{m}{r} \frac{L^2}{m^2 r^2} = \frac{L^2}{mr^3}$$

$$\left[ \text{As } L = mvr \therefore v = \frac{L}{mr} \right]$$

619 (d)

$$\alpha = \frac{2\pi(n_2 - n_1)}{t} = \frac{2\pi \left( \frac{4500 - 1200}{60} \right)}{10} \text{ rad/s}^2$$

$$= \frac{2\pi \frac{3300}{60}}{10} \times \frac{360 \text{ degree}}{2\pi \text{ s}^2} \alpha = 1980 \text{ degree/s}^2$$

620 (c)

Moment of inertia of a hollow sphere of radius  $R$  about the diameter passing through  $D$  is

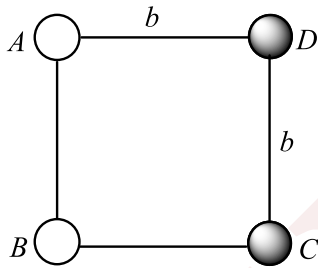

$$I_A = \frac{2}{5} MR^2 \quad \dots(i)$$

Moment of inertia of solid sphere about diameter

$$I_B = \frac{2}{5} MR^2 \quad \dots(ii)$$

$\therefore$  Moment of inertia of whole system about side

$$\begin{aligned} AD &= I_A + I_D + I_B + I_C \\ &= \frac{2}{3} MR^2 + \frac{2}{5} MR^2 + \left( Mb^2 + \frac{2}{3} MR^2 \right) + \left( Mb^2 + \frac{2}{5} MR^2 \right) \\ &= \frac{32}{15} MR^2 + 2Mb^2 \end{aligned}$$

621 (c)

$$P = mv$$

$$\therefore m = \frac{p}{v}$$

Hence,  $m - v$  graph will be rectangular hyperbola

622 (b)

$$\frac{I_1}{I_2} = \left( \frac{M_1}{M_2} \right) \left( \frac{R_1}{R_2} \right)^2 = \frac{1}{2} \times \left( \frac{2}{1} \right)^2 = 2$$

623 (d)

When a particle is projected with a speed  $v$  at  $45^\circ$  with the horizontal then velocity of the projectile at maximum height.

$$v' = v \cos 45^\circ = \frac{v}{\sqrt{2}}$$



Angular momentum of the projectile about the point of projection

$$= mv'h$$

$$= m \frac{v}{\sqrt{2}} h = \frac{mvh}{\sqrt{2}}$$

624 **(d)**

$$\tau = \mathbf{r} \times \mathbf{F}$$

$\tau$  is perpendicular to both  $\mathbf{r}$  and  $\mathbf{F}$ , so  $\mathbf{r} \cdot \tau$  as well as  $\mathbf{F} \cdot \tau$  has to be zero.

625 **(c)**

$$K = \frac{p^2}{2m}$$

$$p^2 = 2Km$$

This is an equation of parabola. Hence, (c) is correct.

626 **(a)**

Moment of inertia of a disc about a diameter is

$$\frac{1}{4} MR^2 = I \quad (\text{given})$$

$$\therefore MR^2 = 4I$$

$$\text{Now, required moment of inertia} = \frac{3}{2} MR^2$$

$$= \frac{3}{2} (4I) = 6I$$

627 **(b)**

$$\text{As } E = \frac{1}{2} I \omega^2$$

$$\omega = \sqrt{\frac{2E}{I}} = \sqrt{\frac{2 \times 600}{3.0}} = 20$$

$$\omega = \frac{2\pi}{T} = 20, T = \frac{2\pi}{20} = \frac{\pi}{10} = 0.314 \text{ s}$$

628 **(c)**

As shown in adjoining figure ball is falling from height  $2h$  and rebounding to a height  $h$  only. It means that velocity of ball just before collision

$$u = \sqrt{\frac{2(2h)g}{g}} = \sqrt{\frac{4h}{g}} \text{ and velocity just after collision}$$

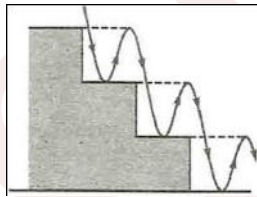

$$v = -\sqrt{\frac{2h}{g}}$$

$$\therefore e = \frac{-v \sqrt{\frac{2h}{g}}}{u \sqrt{\frac{4h}{g}}} = \frac{1}{\sqrt{2}}$$

629 **(d)**

$$K_R = K_T \Rightarrow \frac{1}{2} mv^2 \left( \frac{K^2}{R^2} \right) = \frac{1}{2} mv^2 \Rightarrow \therefore \frac{K^2}{R^2} = 1$$

i. e. the body is ring

630 **(a)**



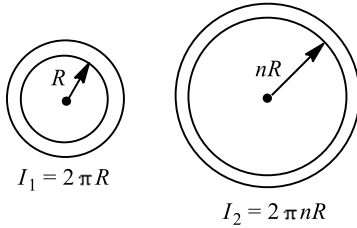

Ratio of moment of inertia of the rings

$$\frac{I_1}{I_2} = \frac{\left(\frac{M_1}{M_2}\right) \left(\frac{R_1}{R_2}\right)^2}{\left(\frac{\lambda L_1}{\lambda L_2}\right) \left(\frac{R_1}{R_2}\right)^2} = \left(\frac{2\pi R}{2\pi nR}\right) \left(\frac{R}{nR}\right)^2$$

( $\lambda$ ) = linear density of wire = constant

(given)

$$\Rightarrow \frac{L_1}{L_2} = \frac{1}{n^3} = \frac{1}{8}$$

$$\therefore n^3 = 8 \Rightarrow n = 2$$

631 (d)

Since  $v_{C.M.} = 0$  so it's linear momentum = 0

632 (b)

Centre of Mass of a solid body is given by

$$x_{CM} = \frac{\sum_{i=1}^n \Delta m_i x_i}{\sum_{j=1}^n \Delta M_j}$$

$$y_{CM} = \frac{\sum_{i=1}^n \Delta m_i y_i}{\sum_{j=1}^n \Delta M_j}$$

$$z_{CM} = \frac{\sum_{i=1}^n \Delta m_i z_i}{\sum_{j=1}^n \Delta M_j}$$

$$1 \times x_1 + 2 \times x_2 + 3 \times x_3 = (1 + 2 + 3)3 \quad \dots(i)$$

and  $x_1 = x_2 = x_3 = 3$

$$x_{CM} = y_{CM} = z_{CM} = 1 \quad \text{(given)}$$

$$1(1 + 2 + 3 + 4) = 1x_1 + 2x_2 + 3x_3 + 4x_4 \quad \dots(ii)$$

Solving Eqs. (i) and (ii), we get

$$4x_4 = 10 - 18$$

$$x_4 = -2$$

Similarly,  $y_4 = -2, z_4 = -2$

The fourth particle must be placed at the point (-2, -2, -2).

634 (a)

$\omega_1 = 2\pi \text{ rad/day}, \omega_2 = 0$  and  $t = 1 \text{ day}$

$$\therefore \alpha = \frac{\omega_2 - \omega_1}{t} = \frac{0 - 2\pi}{1} = 2\pi \frac{\text{rad}}{\text{day}^2} = \frac{2\pi}{(86400)^2} \frac{\text{rad}}{\text{s}^2}$$

Torque required to stop the earth  $\tau = I\alpha = FR$

$$\Rightarrow F = \frac{I\alpha}{R} = \frac{\frac{2}{5}MR^2 \times \alpha}{R} = \frac{2}{5}MR \times \alpha$$

$$= \frac{2}{5} \times 6 \times 10^{24} \times 6400 \times 10^3 \times \frac{2\pi}{(86400)^2} = 1.3 \times 10^{22} \text{ N}$$

635 (b)

Let  $R_1$  be the present distance between earth and sun and  $T_1$  is duration of year. Let  $R_1$  and  $T_2$  be new values of distance and duration of year. By conservation of angular momentum we have

$$I_1 \omega_1 = I_2 \omega_2,$$



$$\text{or } \left(\frac{2}{5}MR_1^2\right)\frac{2\pi}{T_1} = \left(\frac{2}{5}mR_2^2\right)\frac{2\pi}{T_2}$$

$$\begin{aligned} \text{or } T_2 &= T_1 \frac{R_2^2}{R_1^2} \\ &= (365) \times \frac{(R_1/2)^2}{R_1^2} \\ &= \frac{365}{4} = 91.25 \text{ days} \end{aligned}$$

Hence, duration of year will become less.

636

**(d)**

As no external torque is acting about the axis, angular momentum of system remains conserved.

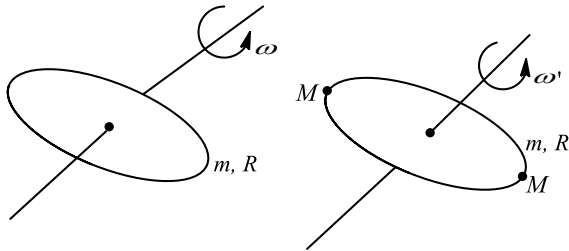

$$\begin{aligned} \therefore I_1\omega &= I_2\omega' \\ \Rightarrow mR^2\omega &= (mR^2 + 2MR^2)\omega' \\ \Rightarrow \omega' &= \left(\frac{m}{m+2M}\right)\omega \end{aligned}$$

637

**(d)**

Distance of corner mass from opposite side

$$r = \sqrt{l^2 - (l/2)^2} = \frac{\sqrt{3}}{2}l$$

$$I = mr^2 = \frac{3}{4}ml^2$$

638

**(a)**

In the pulley arrangement  $|\vec{a}_1| = |\vec{a}_2| = a = \left(\frac{m_1 - m_2}{m_1 + m_2}\right)g$

But  $\vec{a}_1$  is in downward direction and in the upward direction *ie*,  $\vec{a}_2 = -\vec{a}_1$

$\therefore$  Acceleration of centre of mass

$$\begin{aligned} \vec{a}_{\text{CM}} &= \frac{m_1\vec{a}_1 + m_2\vec{a}_2}{m_1 + m_2} = \frac{m_1 \left[\frac{m_1 - m_2}{m_1 + m_2}\right]g - m_2 \left[\frac{m_1 - m_2}{m_1 + m_2}\right]g}{(m_1 + m_2)} \\ &= \left[\frac{m_1 - m_2}{m_1 + m_2}\right]^2 g \end{aligned}$$

639

**(a)**

Due to application of centripetal force its linear momentum changes continuously but torque on the particle is zero so its angular momentum will be conserved

640

**(b)**

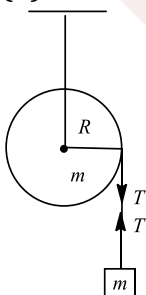

For the motion of the block



$$mg - T = ma \quad \dots(i)$$

For the rotation of the pulley

$$\tau = TR = I\alpha$$

$$\Rightarrow T = \frac{1}{2}mR\alpha \quad \dots(ii)$$

As string does not slip on the pulley

$$a = R\alpha \quad \dots(iii)$$

On solving Eqs. (i), (ii) and (iii)

$$a = \frac{2g}{3}$$

641 (d)

Total kinetic energy

Rotational kinetic energy

$$= \frac{\frac{1}{2}mv^2 \left(1 + \frac{K^2}{R^2}\right)}{\frac{1}{2}mv^2 \frac{K^2}{R^2}} = \frac{1 + \frac{K^2}{R^2}}{\frac{K^2}{R^2}} = \frac{1 + \frac{1}{2}}{\frac{1}{2}} = \frac{3/2}{1/2} = 3$$

643 (b)

$$x = \frac{m_1x_1 + m_2x_2 + m_3x_3}{m_1 + m_2 + m_3} = \frac{m(1 + 2 + 3)}{3m} = 2$$

$$\text{Similarly, } y = \frac{m(1+2+3)}{3m} = 2$$

644 (b)

We know  $m_1r_1 = m_2r_2 \Rightarrow m \times r = \text{constant} \therefore r \propto \frac{1}{m}$

645 (a)

$$a = \frac{g \sin \theta}{1 + I/mr^2} = \frac{g \sin 30^\circ}{1 + \frac{2}{5}} = \frac{5}{7}g \times \frac{1}{2} = \frac{5g}{14}$$

646 (d)

The moment of inertia of the uniform rod about an axis through one end and perpendicular to its length is

$$I = \frac{ml^2}{3}$$

Where  $m$  is mass of rod and  $l$  is length.

Torque ( $\tau = I\alpha$ ) acting on centre of gravity of rod is given by

$$\tau = mg \frac{1}{2}$$

$$\text{or } I\alpha = mg \frac{1}{2}$$

$$\text{or } \frac{ml^2}{3} \alpha = mg \frac{1}{2}$$

$$\text{or } \alpha = \frac{3g}{2l}$$



## PHYSICS

### 7. SYSTEM OF PARTICLES AND ROTATIONAL MOTION

---

#### Assertion - Reasoning Type

This section contain(s) 0 questions numbered 1 to 0. Each question contains STATEMENT 1(Assertion) and STATEMENT 2(Reason). Each question has the 4 choices (a), (b), (c) and (d) out of which **ONLY ONE** is correct.

- a) Statement 1 is True, Statement 2 is True; Statement 2 **is** correct explanation for Statement 1
- b) Statement 1 is True, Statement 2 is True; Statement 2 **is not** correct explanation for Statement 1
- c) Statement 1 is True, Statement 2 is False
- d) Statement 1 is False, Statement 2 is True

1

**Statement 1:** The angular momentum under a central force is constant.

**Statement 2:** Inverse square law of force is conservative.

2

**Statement 1:** A ladder is more apt to slip, when you are high up on it than when you just begin to climb

**Statement 2:** At the high up on a ladder, the torque is large and on climbing up the torque is small

3

**Statement 1:** A wheel moving down a perfectly frictionless inclined plane will undergo slipping (not rolling motion)

**Statement 2:** For perfect rolling motion, work done against friction is zero

4

**Statement 1:** When ice on polar caps of earth melts, duration of the day increases

**Statement 2:**  $L = L\omega = I \cdot \frac{2\pi}{T} = \text{constant}$

5

**Statement 1:** If there is no external torque on a body about its center of mass, then the velocity of the center of mass remains constant

**Statement 2:** The linear momentum of an isolated system remains constant



6

**Statement 1:** Radius of gyration of body is a constant quantity

**Statement 2:** The radius of gyration of a body about an axis of rotation may be defined as the root mean square distance of the particle from the axis of rotation

7

**Statement 1:** Torque is equal to rate of change of angular momentum

**Statement 2:** Angular momentum depends on moment of inertia and angular velocity

8

**Statement 1:** The position of centre of mass of a body does not depend upon shape and size of the body

**Statement 2:** Centre of mass of a body lies always at the centre of the body

9

**Statement 1:** The total kinetic energy of a rolling solid sphere is the sum of translational and rotational kinetic energies

**Statement 2:** For all solid bodies total kinetic energy is always twice the translational kinetic energy

10

**Statement 1:** The velocity of a body at the bottom of an inclined plane of given height is more when it slides down the plane compared to when it rolls down the same plane

**Statement 2:** In rolling down, a body acquires both, KE of translation and KE of rotation

11

**Statement 1:** When a body dropped from a height explodes in mid air, its centre of mass keeps moving in vertically downward direction

**Statement 2:** Explosion occur under internal forces only. External force is zero

12

**Statement 1:** In rolling, all points of a rigid body have the same linear speed

**Statement 2:** The rotational motion does not affect the linear velocity of rigid body

13

**Statement 1:** It is harder to open and shut the door if we apply force near the hinge

**Statement 2:** Torque is maximum at hinge of the door

14

**Statement 1:** The speed of whirlwind in a tornado is alarmingly high

**Statement 2:** If no external torque acts on a body, its angular velocity remains conserved



15

**Statement 1:** Moment of inertia of circular ring about a given axis is more than moment of inertia of the circular disc of same mass and same size, about the same axis

**Statement 2:** The circular ring hollow so its moment of inertia is more than circular disc which is solid

16

**Statement 1:** The centre of mass of a body will change with the change in shape and size of the body.

**Statement 2:** 
$$\vec{r} = \frac{\sum_{i=1}^{i=n} m_i \vec{r}_i}{\sum_{i=1}^{i=n} m_i}$$

17

**Statement 1:** Torque due to force is maximum when angle between  $\vec{r}$  and  $\vec{F}$  is  $90^\circ$

**Statement 2:** The unit of torque is newton-metre

18

**Statement 1:** A particle is moving on a straight line with a uniform velocity, its angular momentum is always zero

**Statement 2:** The momentum is zero when particle moves with a uniform velocity

19

**Statement 1:** Moment of inertia of a particle is same, whatever be the axis of rotation

**Statement 2:** Moment of inertia depends on mass and distance of the particles

20

**Statement 1:** At the centre of earth, a body has centre of mass, but no centre of gravity

**Statement 2:** Acceleration due to gravity is zero at the centre of earth

21

**Statement 1:** The centre of mass of a two particle system lies on the line joining the two particles, being closer to the heavier particle

**Statement 2:** This is because product of mass of one particle and its distance from centre of mass is numerically equal to product of mass of other particle and its distance from centre of mass

22

**Statement 1:** Inertia and moment of inertia are same quantities

**Statement 2:** Inertia represents the capacity of a body to oppose its state of motion or rest

23

**Statement 1:** Torque is time rate of change of a parameter, called angular momentum



- 24  
**Statement 2:** This is because in linear motion, force represents time rate of change of linear momentum
- Statement 1:** The centre of mass of an electron and proton, when released moves faster towards proton  
**Statement 2:** Proton is heavier than electron
- 25  
**Statement 1:** The centre of mass of system of  $n$  particles is the weighted average of the position vector of the  $n$  particles making up the system  
**Statement 2:** The position of the centre of mass of a system is independent of coordinate system
- 26  
**Statement 1:** The centre of mass of a proton and an electron, released from their respective positions remains at rest  
**Statement 2:** The centre of mass remain at rest, if no external force is applied
- 27  
**Statement 1:** If there is no external torque on a body about its center of mass, then the velocity of the center of mass remains constant.  
**Statement 2:** The linear momentum of an isolated system remains constant.
- 28  
**Statement 1:** The centre of mass of body may lie there is no mass.  
**Statement 2:** Centre of mass of a body is a point, where the whole mass of the body is supposed to be concentrated
- 29  
**Statement 1:** Two Cylinders, one hollow (metal) and the other solid (wood) with the same mass and identical dimensions are simultaneously allowed to roll without slipping down an inclined plane from the same height. The hollow cylinder will reach the bottom of the inclined plane first  
**Statement 2:** By the principle of conservation of energy, the total kinetic energies of both the cylinders are identical when they reach the bottom of the incline
- 30  
**Statement 1:** The centre of mass of an electron and proton, when released moves faster towards proton  
**Statement 2:** This is because proton is heavier
- 31  
**Statement 1:** A judo fighter in order to throw his opponent on to the matties he initially bend his opponent and then rotate him around his hip



32 **Statement 2:** As the mass of the opponent is brought closer to the fighter's hip, the force required to throw the opponent is reduced

**Statement 1:** There are two propellers in a helicopter

**Statement 2:** Angular momentum is conserved

33 **Statement 1:** A shell at rest, explodes. The centre of mass of fragments moves along a straight path

**Statement 2:** In explosion the linear momentum of the system remains always conserved

34 **Statement 1:** The centre of mass of a body may lie where there is no mass

**Statement 2:** The centre of mass has nothing to do with the mass

35 **Statement 1:** The centre of mass of a two particle system lies on the line joining the two particles, being closer to the heavier particle

**Statement 2:** Product of mass of one particle and its distance from centre of mass is numerically equal to product of mass of other particle and its distance from centre of mass

36 **Statement 1:** The centre of mass of a body may lie where there is no mass

**Statement 2:** Centre of mass of a body is a point, where the whole mass of the body is supposed to be concentrated



## PHYSICS

### 7. SYSTEM OF PARTICLES AND ROTATIONAL MOTION

#### : ANSWER KEY :

- |     |   |     |   |     |   |     |   |
|-----|---|-----|---|-----|---|-----|---|
| 1)  | b | 2)  | a | 3)  | b | 4)  | a |
| 5)  | d | 6)  | d | 7)  | b | 8)  | d |
| 9)  | c | 10) | b | 11) | a | 12) | d |
| 13) | c | 14) | c | 15) | b | 16) | a |
| 17) | b | 18) | d | 19) | d | 20) | a |
| 21) | a | 22) | d | 23) | d | 24) | d |
| 25) | b | 26) | a | 27) | d | 28) | a |
| 29) | d | 30) | d | 31) | a | 32) | b |
| 33) | d | 34) | b | 35) | a | 36) | a |



## PHYSICS

### 7. SYSTEM OF PARTICLES AND ROTATIONAL MOTION

#### : HINTS AND SOLUTIONS :

- 1 **(b)**  
The angular momentum under a central force is a constant and inverse square law of force is conservative.
- 2 **(a)**  
When a person is high up on the ladder, than a large torque is produced due to his weight about the point of contact between the ladder and the floor. Whereas when he starts climbing up. The torque is small. Due to this reason, the ladder is more apt to slip, when one is high up on it
- 3 **(b)**  
Rolling occurs only on account of friction which is a tangential force capable of providing torque. When the inclined plane is perfectly smooth, body will simply slip under the effect of its own weight
- 4 **(a)**  
Both, the assertion and reason are true and latter is a correct explanation of the former. Infact, as ice on polar caps of earth melts, mass near the polar axis spreads out,  $I$  increases. Therefore,  $T$  increases *ie*, duration of day increases
- 5 **(d)**  
Velocity of center of mass of a body is constant when no external force acts on the body. If there is no external torque, it does not mean that no external force acts on it
- 6 **(d)**  
Radius of gyration of body is not a constant quantity. Its value changes with the change in location of the axis of rotation. Radius of gyration of a body about a given axis is given as
- $$K = \sqrt{\frac{r_1^2 + r_2^2 + \dots + r_n^2}{n}}$$
- 7 **(b)**  
 $\vec{\tau} = \frac{d\vec{L}}{dt}$  and  $L = I\omega$
- 8 **(d)**  
The position of centre of mass of a body depends on shape, size and distribution of mass of the body. The centre of mass does not lie necessarily at the centre of the body
- 9 **(c)**  
 $K_N = K_R + K_T$



This equation is correct for any body which is rolling without slipping

For the ring and hollow cylinder only  $K_R = K_T$

*i. e.*  $K_N = 2K_T$

10 **(b)**

In sliding down, the entire PE is converted only into linear KE. In rolling down, a part of same PE is converted into KE of rotation. Therefore, velocity acquired is less. Both the statements are true, but statement-2 is not a correct explanation of statement

11 **(a)**

Explosion is due to internal forces. As no external force is involved, the vertical downward motion of centre of mass is not affected

12 **(d)**

In rolling all points of rigid body have the same angular speed but different linear speed

13 **(c)**

Torque = Force  $\times$  perpendicular distance of line of action of force from the axis of rotation (d)

Hence for a given applied force, torque or true tendency of rotation will be high for large value of  $d$ . If distance  $d$  is smaller, then greater force is required to cause the same torque, hence it is harder to open or shut down the door by applying a force near the hinge

14 **(c)**

In a whirlwind in a tornado, the air from nearby regions gets concentrated in a small space thereby decreasing the value of its moment of inertia considerably. Since,  $I\omega = \text{constant}$ , so due to decrease in moment of inertia of the air, its angular speed increases to a high value

If no external torque acts, then

$$\tau = 0 \Rightarrow \frac{dL}{dt} = 0 \text{ or } L = \text{constant} \Rightarrow I\omega = \text{constant}$$

As in the rotational motion, the moment of inertia of the body can change due to the change in position of the axis of rotation, the angular speed may not remain conserved

15 **(b)**

In the case of circular ring the mass is concentrated on the rim (at maximum distance from the axis) therefore moment of inertia increases as compared to that in circular disc

16 **(a)**

Position vector of centre of mass depends on masses of particles and their location. Therefore, change in shape/size of body do change the centre of mass

17 **(b)**

$$\tau = r F \sin \theta. \text{ If } \theta = 90^\circ \text{ then } \tau_{max} = rF$$

Unit of torque is  $N - m$

18 **(d)**



When particle moves with constant velocity  $\vec{v}$  then its linear momentum has some finite value ( $\vec{P} = m\vec{v}$ )

Angular momentum ( $L$ ) = Linear momentum ( $P$ )  $\times$  Perpendicular distance of line of action of linear momentum from the point of rotation ( $d$ )

So if  $d \neq 0$  then  $L \neq 0$ , but if  $d = 0$  then  $L$  may be zero. So we can conclude that angular momentum of a particle moving with constant velocity is not always zero

- 19 **(d)**  
The moment of inertia of a particle about an axis of rotation is given by the product of the mass of the particle and the square of the perpendicular distance of the particle from the axis of rotation. For different axis, distance would be different, therefore moment of inertia of a particle changes with the change in axis of rotation
- 20 **(a)**  
At the centre of earth,  $g = 0$ . Therefore a body has no weight at the centre of earth and have no centre of gravity (centre of gravity of a body is the point where the resultant force of attraction or the weight of the body acts). But centre of mass of a body depends on mass and position of particles and is independent of weight
- 21 **(a)**  
The assertion is true and reason is correct explanation of the assertion.
- 22 **(d)**  
There is a difference between inertia and moment of inertia of a body. The inertia of a body depends only upon the mass of the body but the moment of inertia of a body about an axis not only depends upon the mass of the body but also upon the distribution of mass about the axis of rotation
- 23 **(d)**  
Angular momentum is rotational analogue of linear momentum, and torque is rotational analogue of force.
- 24 **(d)**  
The position of centre of mass of electron and proton remains at rest. As their motion is due to internal force of electrostatic attraction, which is conservative force. No external force is acting on the two particles, therefore centre of mass remain at rest
- 26 **(a)**  
Initially the electron and proton were at rest so their centre of mass will be at rest. When they move towards each other under mutual attraction then velocity of centre of mass remains unaffected because external force on the system is zero
- 27 **(d)**  
If a force is applied at centre of mass of a rigid body, its torque about centre of mass will be zero, but acceleration will be non-zero. Hence, velocity will change.



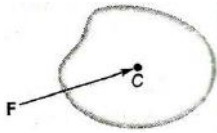

- 28 **(a)**  
As the concept of centre of mass is only theoretical, therefore in practice no mass may lie at the centre of mass. For example, centre of mass of a uniform circular ring is at the centre of the ring where there is no mass.
- 29 **(d)**  
Time of descent from inclined plane
- $$t = \frac{1}{\sin \theta} \sqrt{\frac{2h}{g} \left(1 + \frac{K^2}{R^2}\right)}$$
- As  $\left(\frac{K^2}{R^2}\right)_{\text{solid cylinder}} < \left(\frac{K^2}{R^2}\right)_{\text{Hollow cylinder}}$
- Therefore solid cylinder will reach the bottom first  
i.e., statement 1 is wrong
- As they possess equal potential energy initially at the top therefore their kinetic energies will also be equal at the bottom, i.e., statement 2 is true
- 30 **(d)**  
The position of centre of mass of electron and proton remains at rest, at their motion is due to (internal) forces of electrostatic attraction, which are conservative. No external force, what so ever is acting on the two particles
- 31 **(a)**  
Through bending weight of opponent is made to pass through the hip of judo fighter to make its torque zero
- 32 **(b)**  
Both, assertion and reason are true but the reason is not a correct explanation of the statement-1. Infact, if helicopter has only one propeller, the helicopter itself would turn in opposite direction to conserve the angular momentum
- 33 **(d)**  
As the shell is initially at rest and after explosion, according to law of conservation of linear momentum, the centre of mass remains at rest. While parts of shell move in all direction, such that total momentum of all parts is equal to zero
- 34 **(b)**  
The assertion and reason, both are true. But the reason is not a correct explanation of the assertion. Infact, the centre of mass is related to the distribution of mass of the body
- 35 **(a)**



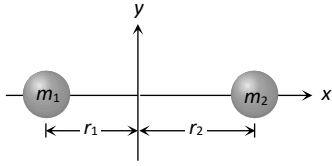

If centre of mass of system lies at origin then  $\vec{r}_{cm} = 0$

$$\vec{r}_{cm} = \frac{m_1 \vec{r}_1 + m_2 \vec{r}_2}{m_1 + m_2}$$

$$\therefore m_1 \vec{r}_1 + m_2 \vec{r}_2 = 0$$

$$\text{Or } m_1 r_1 = m_2 r_2$$

It is clear that if  $m_1 > m_2$  then

36

(a)

As the concept of centre of mass is only theoretical, therefore in practice no mass may lie at the centre of mass. For example, centre of mass of a uniform circular ring is at the centre of the ring where there is no mass

Session: 2025-26

Total Questions: 683

## PHYSICS

### 7. SYSTEM OF PARTICLES AND ROTATIONAL MOTION

#### Matrix-Match Type

This section contain(s) 0 question(s). Each question contains Statements given in 2 columns which have to be matched. Statements (A, B, C, D) in **columns I** have to be matched with Statements (p, q, r, s) in **columns II**.

- Each of the body in column I show the moment of inertia about its diameter in column II. Select the correct answer (matching list I with List II) as per code given below the lists.

#### Column-I

- (A) Ring  
(B) Disc  
(C) Annular Disc

#### Column- II

- (1)  $\frac{M}{4}(R_1^2 + R_2^2)$   
(2)  $\frac{1}{4}MR^2$   
(3)  $\frac{1}{2}MR^2$



**CODES :**

	<b>A</b>	<b>B</b>	<b>C</b>	<b>D</b>
<b>a)</b>	2	3	1	
<b>b)</b>	3	2	1	
<b>c)</b>	3	1	2	
<b>d)</b>	1	2	3	

Session: 2025-26

Total Questions: 683

## PHYSICS

### 7. SYSTEM OF PARTICLES AND ROTATIONAL MOTION

---

**: ANSWER KEY :**

1) **b**



## PHYSICS

### 7. SYSTEM OF PARTICLES AND ROTATIONAL MOTION

#### : HINTS AND SOLUTIONS :

- 1 (b)
- The moment of inertia of a ring about its diameter =  $\frac{1}{2}MR^2$
- The moment of inertia of a disc about its diameter =  $\frac{1}{4}Ma^2$
- The moment of inertia of an annular disc about its diameter =  $\frac{1}{4}M(R_1^2 + R_2^2)$

