

**Physics (Class 11)**

**Chapter 4: MOTION IN A PLANE**

**SKYLIMIT EDUCATION**

Doltala, Madhyamgram, Kolkata-700132

## 4. MOTION IN A PLANE

### Single Correct Answer Type

- A particle is projected at an angle of elevation  $\alpha$  and after  $t$  second, it appears to have an angle of elevation  $\beta$  as seen from point of projection. The initial velocity will be  
 a)  $\frac{gt}{2 \sin(\alpha - \beta)}$       b)  $\frac{gt \cos \beta}{2 \sin(\alpha - \beta)}$       c)  $\frac{\sin(\alpha - \beta)}{2gt}$       d)  $\frac{2 \sin(\alpha - \beta)}{gt \cos \beta}$
- A particle reaches its highest point when it has covered exactly one half of its horizontal range. The corresponding point on the vertical displacement-time graph is characterised by  
 a) Zero slope and zero curvature      b) Zero slope and non-zero curvature  
 c) Positive slope and zero curvature      d) None of these
- A car travelling at a constant speed of  $20 \text{ ms}^{-1}$  starts overtaking another car which is moving at constant acceleration of  $2 \text{ ms}^{-2}$  and it is initially at rest. Assume the length of each car to be 5 m. The total road distance used in overtaking is  
 a) 394.74 m      b) 15.26 m      c) 200.00 m      d) 186.04 m
- A plane flying horizontally at  $100 \text{ ms}^{-1}$  releases an object which reaches the ground in 10 s. At what angle with horizontal it hits the ground?  
 a)  $55^\circ$       b)  $45^\circ$       c)  $60^\circ$       d)  $75^\circ$
- A river is flowing from west to east at a speed of 5 m/min. A man on the south bank of the river, capable of swimming at 10 m/min in still water, wants to swim across the river in the shortest time. Finally he will move in a direction  
 a)  $\tan^{-1}(2)$ E of N      b)  $\tan^{-1}(2)$ N of E      c)  $30^\circ$  E of N      d)  $60^\circ$  E of N
- The trajectory of a projectile in a vertical plane is  $y = ax - bx^2$ , where  $a$  and  $b$  are constants and  $x$  and  $y$  are, respectively, horizontal and vertical distance of the projectile from the point of projection. The maximum height attained by the particle and the angle of projection from the horizontal are  
 a)  $\frac{b^2}{2a}, \tan^{-1}(b)$       b)  $\frac{a^2}{b}, \tan^{-1}(2b)$       c)  $\frac{a^2}{4b}, \tan^{-1}(a)$       d)  $\frac{2a^2}{b}, \tan^{-1}(a)$
- A particle is moving along the locus  $y = k - x (k > 0)$  with a constant speed  $v$ . At  $t = 0$ , it is at the origin and about to  $0, v_x - v_y$ . At this moment,  $[a_y - a_x] =$   
 a)  $v^2/k^2$       b) Zero      c)  $-v^2/k^2$       d) None
- A small body is dropped from a rising balloon. A person  $A$  stands on ground, while another person  $B$  is on the balloon. Choose the correct statement: Immediately, after the body is released  
 a) Both  $A$  and  $B$ , feel that the body is coming (going) down  
 b) Both  $A$  and  $B$ , feel that the body is going up  
 c)  $A$  feels that the body is coming down, while  $B$  feels that the body is going up  
 d)  $A$  feels that the body is going up, while  $B$  feels that the body is going down
- A particle is projected from the ground with an initial speed of  $v$  at an angle  $\theta$  with horizontal. The average velocity of the particle between its point of projection and highest point of trajectory is  
 a)  $\frac{v}{2}\sqrt{1 + 2 \cos^2 \theta}$       b)  $\frac{v}{2}\sqrt{1 + 2 \cos^2 \theta}$       c)  $\frac{v}{2}\sqrt{1 + 3 \cos^2 \theta}$       d)  $v \cos \theta$
- A particle is projected from ground at some angle with the horizontal. Let  $P$  be the point at maximum height  $H$ . At what height above the point  $P$  should the particle be aimed to have range equal to maximum height?  
 a)  $H$       b)  $2H$       c)  $H/2$       d)  $3H$



11. The friction of air causes a vertical retardation equal to 10% of the acceleration due to gravity (take  $g = 10 \text{ ms}^{-2}$ ). The maximum height will be decreased by  
 a) 8%                                      b) 9%                                      c) 10%                                      d) 11%
12. A small mass  $m$  is attached to a massless string whose other end is fixed at  $P$  as shown in the figure. The mass is undergoing circular motion in the  $x - y$  plane with centre at  $O$  and constant angular speed  $\omega$ . If the angular momentum of the system, calculated about  $O$  and  $P$  are denoted by  $\vec{L}_O$  and  $\vec{L}_P$  respectively, then

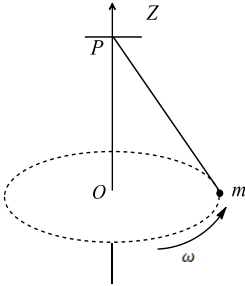

- a)  $\vec{L}_O$  and  $\vec{L}_P$  do not vary with time                                      b)  $\vec{L}_O$  varies with time while  $\vec{L}_P$  remains constant  
 c)  $\vec{L}_O$  remains constant while  $\vec{L}_P$  varies with time                                      d)  $\vec{L}_O$  and  $\vec{L}_P$  both vary with time
13. An object has velocity  $\vec{v}_1$  w.r.t ground. An observer moving with constant velocity  $\vec{v}_0$  w.r.t ground measures the velocity of the object as  $\vec{v}_2$ . The magnitudes of three velocities are related by  
 a)  $v_0 \geq v_1 + v_2$                                       b)  $v_1 \leq v_2 + v_0$                                       c)  $v_2 \geq v_1 + v_0$                                       d) All of the above
14. There are two values of time for which a projectile is at the same height. The sum of these two times is equal to ( $T =$  time of flight of the projectile)  
 a)  $3T/2$                                       b)  $4T/3$                                       c)  $3T/4$                                       d)  $T$
15. A number of bullets are fired in all possible directions with the same initial velocity  $u$ . The maximum area of ground covered by bullets is  
 a)  $\pi \left(\frac{u^2}{g}\right)^2$                                       b)  $\pi \left(\frac{u^2}{2g}\right)^2$                                       c)  $\pi \left(\frac{u}{g}\right)^2$                                       d)  $\pi \left(\frac{u}{2g}\right)^2$
16. A shell fired from the ground is just able to cross horizontally the top of a wall 90 m away and 45 m high. The direction of projection of the shell will be:  
 a)  $25^\circ$                                       b)  $30^\circ$                                       c)  $60^\circ$                                       d)  $45^\circ$
17. A hose lying on the ground shoots a stream of water upward at an angle of  $60^\circ$  to the horizontal with the velocity of  $16 \text{ ms}^{-1}$ . The height at which the water strikes the wall 8 m away is  
 a) 8.9 m                                      b) 10.9 m                                      c) 12.9 m                                      d) 6.9 m
18. A piece of wire is bent in the shape of a parabola  $y = kx^2$  ( $y$ -axis vertical) with a bead of mass  $m$  on it. The bead can slide on the wire without friction. It stays at the lowest point of the parabola when the wire is at rest. The wire is now accelerated parallel to the  $x$ -axis with a constant acceleration  $a$ . The distance of the new equilibrium position of the bead, where the bead can stay at rest with respect to the wire, from the  $y$ -axis is

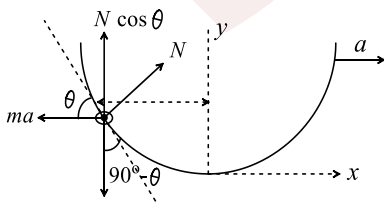

- a)  $a/gk$                                       b)  $a/2gk$                                       c)  $2a/gk$                                       d)  $a/4gk$



19. A bob of mass  $M$  is suspended by a massless string of length  $L$ . The horizontal velocity  $V$  at position  $A$  is just sufficient to make it reach the point  $B$ . The angle  $\theta$  at which the speed of the bob is half of that at  $A$ , satisfies

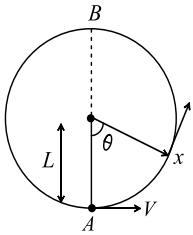

- a)  $\theta = \frac{\pi}{4}$                       b)  $\frac{\pi}{4} < \theta < \frac{\pi}{2}$                       c)  $\frac{\pi}{2} < \theta < \frac{3\pi}{4}$                       d)  $\frac{3\pi}{4} < \theta < \pi$
20. Twelve persons are initially at the twelve corners of a regular polygon of twelve sides of side  $a$ . Each person now moves with a uniform speed  $v$  in such a manner that 1 is always directed towards 2, 2 towards 3, 3 towards 4, and so on. The time after which they meet is
- a)  $\frac{v}{a}$                       b)  $\frac{2a}{v}$                       c)  $\frac{2a}{v(2 + \sqrt{3})}$                       d)  $\frac{2a}{v(2 - \sqrt{3})}$
21. The maximum height reached by projectile is 4 m. The horizontal range is 12 m. The velocity of projection in  $\text{ms}^{-1}$  is ( $g$  is acceleration due to gravity)
- a)  $5\sqrt{g/2}$                       b)  $3\sqrt{g/2}$                       c)  $\frac{1}{3}\sqrt{g/2}$                       d)  $\frac{1}{5}\sqrt{g/2}$
22. Two identical discs of same radius  $R$  are rotating about their axes in opposite directions with the same constant angular speed  $\omega$ . The discs are in the same horizontal plane. At time  $t = 0$ , the points  $P$  and  $Q$  are facing each other as shown in figure. The relative speed between the two points  $P$  and  $Q$  is  $V_r$  as function of times best represented by

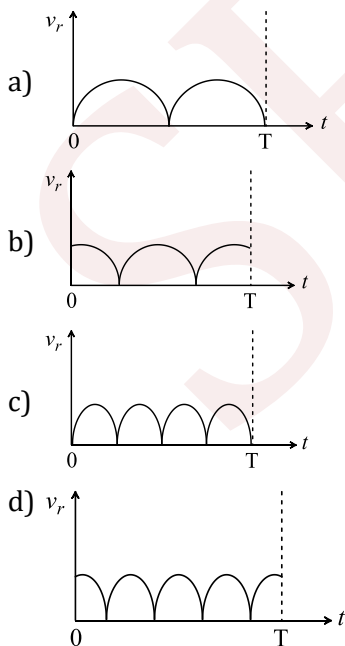
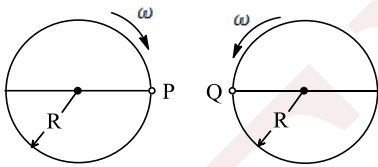

23. A digital watch  $A$  was showing 1:12:32 and an old clock ' $B$ ', not having second hand, was showing 1:10. At that moment, actual time was 1:10:15



- a)  $A$  is more precise but less accurate than  $B$                       b)  $A$  is less precise but more accurate than  $B$   
 c)  $A$  is both more accurate and precise                              d)  $B$  is both more accurate and precise
24. A projectile has initially the same horizontal velocity as it would acquire if it had moved from rest with uniform acceleration of  $3 \text{ ms}^{-2}$  for  $0.5 \text{ min}$ . If the maximum height reached by it is  $80 \text{ m}$ , then the angle of projection is ( $g = 10 \text{ ms}^{-2}$ )  
 a)  $\tan^{-1} 3$                       b)  $\tan^{-1}(3/2)$                       c)  $\tan^{-1}(4/9)$                       d)  $\sin^{-1}(4/9)$
25. Two bullets are fired horizontally with different velocities from the same height. Which will reach the ground first?  
 a) Slower one                      b) Faster one  
 c) Both will reach simultaneously                      d) It cannot be predicted
26. If  $R$  is the maximum horizontal range of a projectile, then the greatest height attained by it is  
 a)  $R$                       b)  $2R$                       c)  $R/2$                       d)  $R/4$
27. The particle is moving along a circular path as shown in Fig. The instantaneous velocity of the particle is  $\vec{v} = (4 \text{ ms}^{-1})\hat{i} - (3 \text{ ms}^{-1})\hat{j}$   
 Through which quadrants does the particle move when it travels clockwise and anticlockwise, respectively, around the circle?

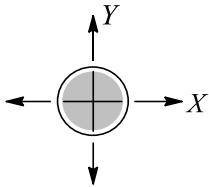

- a) First, first                      b) First, second                      c) First, third                      d) Third, first
28. A particle is moving along the  $x$ -axis whose acceleration is given by  $a = 3x - 4$ , where  $x$  is the location of the particle. At  $t = 0$ , the particle is at rest at  $x = \frac{4}{3} \text{ m}$ . The distance travelled by the particle in  $5 \text{ s}$  is  
 a) Zero                      b)  $42 \text{ m}$                       c) Infinite                      d) None of these
29. Two particles  $P$  and  $Q$  are projected simultaneously away from each other from a point  $A$  as shown in figure. The velocity of  $P$  relative to  $Q$  in  $\text{ms}^{-1}$  at the instant when the motion of  $P$  is horizontal is

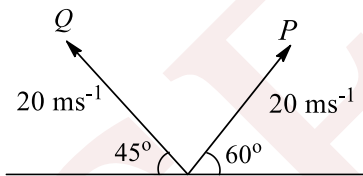

- a)  $10\sqrt{4 - \sqrt{3}}$                       b)  $20\sqrt{4 - \sqrt{3}}$                       c)  $10\sqrt{4 + \sqrt{3}}$                       d)  $20\sqrt{4 + \sqrt{3}}$
30. Rain is falling vertically downwards with a speed of  $4 \text{ kmh}^{-1}$ . A girl moves on a straight road with a velocity of  $3 \text{ kmh}^{-1}$ . The apparent velocity of rain with respect to the girl is  
 a)  $3 \text{ kmh}^{-1}$                       b)  $4 \text{ kmh}^{-1}$                       c)  $5 \text{ kmh}^{-1}$                       d)  $7 \text{ kmh}^{-1}$
31. The velocity of a body moving in a circle in the radial direction is  
 a) 0                      b) Speed of the body                      c)  $v^2/R$                       d) None of the above
32. Three boys are running on an equilateral track with the same speed  $5 \text{ ms}^{-1}$ . At start, they were at the three corners with velocity along indicated directions. The velocity of approach of any one of them towards another at  $t = 10 \text{ s}$  equals



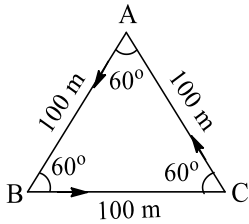

- a)  $7.5 \text{ ms}^{-1}$                       b)  $10 \text{ ms}^{-1}$                       c)  $5 \text{ ms}^{-1}$                       d)  $0 \text{ ms}^{-1}$

33. In Fig, the angle of inclination of the inclined plane is  $30^\circ$ . Find the horizontal velocity  $V_0$  so that the particle hits the inclined plane perpendicularly

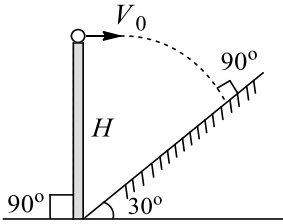

- a)  $V_0 = \sqrt{\frac{2gH}{5}}$                       b)  $V_0 = \sqrt{\frac{2gH}{7}}$                       c)  $V_0 = \sqrt{\frac{gH}{5}}$                       d)  $V_0 = \sqrt{\frac{gH}{7}}$

34. In fig, the time taken by the projectile to reach from A to B is  $t$ . Then the distance AB is equal to

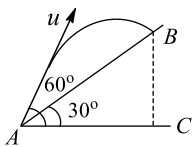

- a)  $\frac{ut}{\sqrt{3}}$                       b)  $\frac{\sqrt{3}ut}{2}$                       c)  $\sqrt{3}ut$                       d)  $2ut$

35. A particle is projected with a velocity  $v$  so that its range on a horizontal plane is twice the greatest height attained. If  $g$  is acceleration due to gravity, then its range is

- a)  $\frac{4v^2}{5g}$                       b)  $\frac{4g}{5v^2}$                       c)  $\frac{4v^3}{5g^2}$                       d)  $\frac{4v}{5g^2}$

36. A projectile is fired from level ground at an angle  $\theta$  above the horizontal. The elevation angle  $\phi$  of the highest point as seen from the launch point is related to  $\theta$  by the relation

- a)  $\tan \phi = 2 \tan \theta$                       b)  $\tan \phi = \tan \theta$                       c)  $\tan \phi = \frac{1}{2} \tan \theta$                       d)  $\tan \phi = \frac{1}{4} \tan \theta$

37. A particle is moving along a circular path with uniform speed. Through what angle does its angular velocity change when it completes half of the circular path?

- a)  $0^\circ$                       b)  $45^\circ$                       c)  $180^\circ$                       d)  $360^\circ$

38. Velocity versus displacement graph of a particle moving in a straight line is shown in Fig. The corresponding acceleration versus velocity graph will be

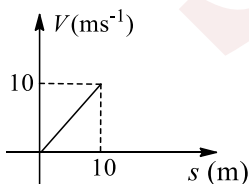

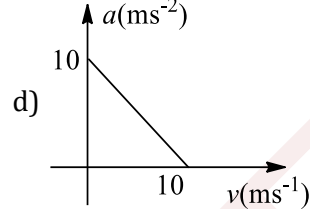
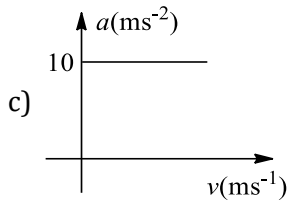
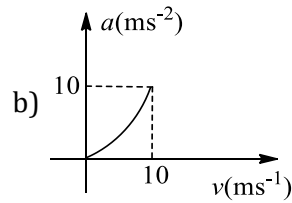
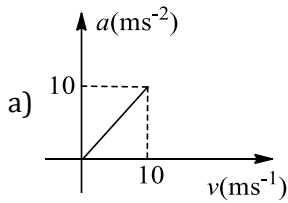

39. A particle is fired with velocity  $u$  making angle  $\theta$  with the horizontal. What is the change in velocity when it is at the highest point?

- a)  $u \cos \theta$                       b)  $u$                       c)  $u \sin \theta$                       d)  $(u \cos \theta - u)$

40. A ball is projected from a point  $A$  with some velocity at an angle  $30^\circ$  with the horizontal as shown in fig. Consider a target at point  $B$ . The ball will hit the target if it is thrown with a velocity  $v_0$  equal to

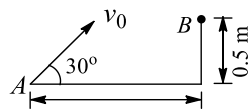

$\sqrt{3}/2 \text{ m}$

- a)  $5 \text{ ms}^{-1}$                       b)  $6 \text{ ms}^{-1}$                       c)  $7 \text{ ms}^{-1}$                       d) None of these

41. A ball is thrown at different angles with the same speed  $u$  and from the same point and it has the same range in both the cases. If  $y_1$  and  $y_2$  are the heights attained in the two cases, then  $y_1 + y_2$  is equal to

- a)  $\frac{u^2}{g}$                       b)  $\frac{2u^2}{g}$                       c)  $\frac{u^2}{2g}$                       d)  $\frac{u^2}{4g}$

42. A particle moves in a circular path with decreasing speed. Choose the correct statement.

- a) Angular momentum remains constant  
b) Acceleration (**a**) is towards the center  
c) Particle moves in a spiral path with decreasing radius  
d) The direction of angular momentum remains constant

43. Two balls  $A$  and  $B$  are thrown with speed  $u$  and  $u/2$ , respectively. Both the balls cover the same horizontal distance before returning to the plane of projection. If the angle of projection of ball  $B$  is  $15^\circ$  with the horizontal, then the angle of projection of  $A$  is

- a)  $\sin^{-1}\left(\frac{1}{8}\right)$                       b)  $\frac{1}{2}\sin^{-1}\left(\frac{1}{8}\right)$                       c)  $\frac{1}{3}\sin^{-1}\left(\frac{1}{8}\right)$                       d)  $\frac{1}{4}\sin^{-1}\left(\frac{1}{8}\right)$

44. The acceleration-time graph of a particle moving in a straight line is shown in Fig. The velocity of the particle at time  $t = 0$  is  $2 \text{ ms}^{-1}$ . The velocity after 2 s will be

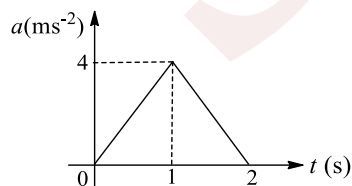

- a)  $6 \text{ ms}^{-1}$                       b)  $4 \text{ ms}^{-1}$                       c)  $2 \text{ ms}^{-1}$                       d)  $8 \text{ ms}^{-1}$

45. A particle is projected with a certain velocity at an angle  $\alpha$  above the horizontal from the foot of an inclined plane of inclination  $30^\circ$ . If the particle strikes the plane normally, then  $\alpha$  is equal to



- a)  $30^\circ + \tan^{-1}\left(\frac{\sqrt{3}}{2}\right)$       b)  $45^\circ$       c)  $60^\circ$       d)  $30^\circ + \tan^{-1}(2\sqrt{3})$

46. A projectile can have the same range  $R$  for two angles of projection. If  $t_1$  and  $t_2$  are the times of flight in the two cases, then what is the product of two times of flight?

- a)  $t_1 t_2 \propto R^2$       b)  $t_1 t_2 \propto R$       c)  $t_1 t_2 \propto \frac{1}{R}$       d)  $t_1 t_2 \propto \frac{1}{R^2}$

47. A particle moves in a circular path with decreasing speed. Choose the correct statement

- a) Angular momentum remains constant  
b) Acceleration ( $\vec{a}$ ) is towards the centre  
c) Particle moves in a spiral path with decreasing radius  
d) The direction of angular momentum remains constant

48. Figure shows the velocity-displacement curve for an object moving along a straight line. At which of the points marked is the object speeding up?

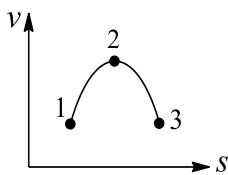

- a) 1      b) 2      c) 1 and 3      d) 1, 2, and 3

49. Range of projectile is  $R$ , when the angle of projection is  $30^\circ$ . Then the value of the other angle of projection for the same range is

- a)  $45^\circ$       b)  $60^\circ$       c)  $50^\circ$       d)  $40^\circ$

50. A river flows with a speed more than the maximum speed with which a person can swim in still water. He intends to cross the river by the shortest possible path (i.e., he wants to reach the point on the opposite bank which directly opposite to the starting point). Which of the following is correct?

- a) He should start normal to the river bank  
b) He should start in such a way that he moves normal to the bank, relative to the bank  
c) He should start in a particular (calculated) direction making an obtuse angle with the direction of water current  
d) The man cannot cross the river in that way

51. A body is projected at  $30^\circ$  with the horizontal. The air offers resistance in proportion to the velocity of the body. Which of the following statements is correct?

- a) The trajectory is a symmetrical parabola  
b) The time of rise to the maximum height is equal to the time of return to the ground  
c) The velocity at the highest point is directed along the horizontal  
d) The sum of the kinetic and potential energies remains constant

52. A ball is projected from the ground at angle  $\theta$  with the horizontal. After 1 s it is moving at angle  $45^\circ$  with the horizontal and after 2 s it is moving horizontally. What is the velocity of projection of the ball?

- a)  $10\sqrt{3}\text{ms}^{-1}$       b)  $20\sqrt{3}\text{ms}^{-1}$       c)  $10\sqrt{5}\text{ms}^{-1}$       d)  $20\sqrt{2}\text{ms}^{-1}$

53. A stone tied to a string of length  $L$  is whirled in a vertical circle with the other end of the string at the centre. At a certain instant of time, the stone is at its lowest position and has speed  $u$ . The magnitude of the change in its velocity as it reaches a position where the string is horizontal is

- a)  $\sqrt{u^2 - 2gL}$       b)  $\sqrt{2gL}$       c)  $\sqrt{u^2 - gL}$       d)  $\sqrt{2(u^2 - gL)}$

54. A motor cyclist is trying to jump across a path as shown in fig by driving horizontally off a cliff  $A$  at a speed of  $5\text{ms}^{-1}$ . Ignore air resistance and take  $g = 10\text{ms}^{-2}$ . The speed with which he touches peak  $B$  is



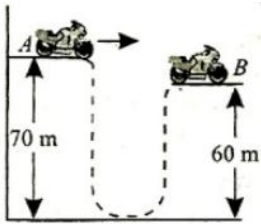

- a)  $20 \text{ ms}^{-1}$                       b)  $12 \text{ ms}^{-1}$                       c)  $25 \text{ ms}^{-1}$                       d)  $15 \text{ ms}^{-1}$
55. A stone of mass  $m$  is tied to a string of length  $l$  and rotated in a circle with a constant speed  $v$ . If the string is released, the stone files
- a) Radially outward  
b) Radially inward  
c) Tangentially outward  
d) With an acceleration  $mv^2/l$
56. The acceleration of a particle starting from rest and travelling along a straight line is shown in the Fig. The maximum speed of the particle is

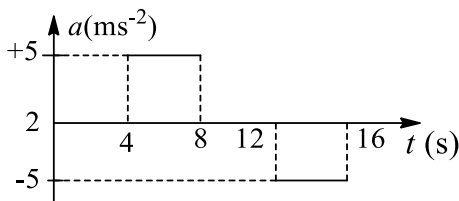

- a)  $20 \text{ ms}^{-1}$                       b)  $30 \text{ ms}^{-1}$                       c)  $40 \text{ ms}^{-1}$                       d)  $60 \text{ ms}^{-1}$
57. Two trains having constant speeds of  $40 \text{ kmh}^{-1}$  and  $60 \text{ kmh}^{-1}$  respectively are heading towards each other on the same straight track

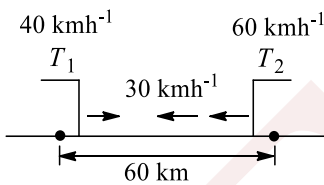

- A bird, when can fly with a constant speed of  $30 \text{ kmh}^{-1}$  files off from one train when they are  $60 \text{ km}$  apart and heads directly for the other train. On reaching the other train, it files back directly to the first and so forth. What is the total distance travelled by the bird before the two trains crash?
- a)  $12 \text{ km}$                       b)  $18 \text{ km}$                       c)  $30 \text{ km}$                       d)  $25 \text{ km}$
58. At what angle with the horizontal should a ball the thrown so that the range  $R$  is related to the time of flight as  $R = 5T^2$ ? (Take  $g = 10 \text{ ms}^{-2}$ )
- a)  $30^\circ$                       b)  $45^\circ$                       c)  $60^\circ$                       d)  $90^\circ$
59. Two balls are projected from point  $A$  and  $B$  in vertical plane as shown in Fig.  $AB$  is a straight vertical line. The balls can collide in mid air if  $v_1/v_2$  is equal to

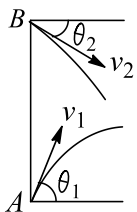

- a)  $\frac{\sin \theta_1}{\sin \theta_2}$                       b)  $\frac{\sin \theta_2}{\sin \theta_1}$                       c)  $\frac{\cos \theta_1}{\cos \theta_2}$                       d)  $\frac{\cos \theta_2}{\cos \theta_1}$
60. When a projectile is fired at an angle  $\theta$  with the horizontal with velocity  $u$ , then its vertical component
- a) Remains the same



- b) Goes on increasing with height  
 c) First decreases and then increases with the height  
 d) First increases then decreases with height
61. During a projectile motion if the maximum height equals the horizontal range, then the angle of projection with the horizontal is  
 a)  $\tan^{-1}(1)$                       b)  $\tan^{-1}(2)$                       c)  $\tan^{-1}(3)$                       d)  $\tan^{-1}(4)$
62. For three particles  $A, B$  and  $C$  moving along  $x$ -axis,  $x-t$  graph is as shown below: Mark out the correct relationships between their average velocities between the points  $P$  and  $Q$

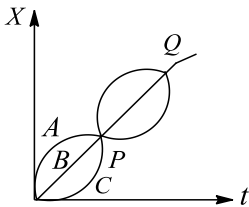

- a)  $v_{av,A} > v_{av,B} = v_{av,C}$                       b)  $v_{av,A} = v_{av,B} = v_{av,C}$   
 c)  $v_{av,A} > v_{av,B} > v_{av,C}$                       d)  $v_{av,A} < v_{av,B} < v_{av,C}$
63. A cannon fires a projectile as shown in Fig. The dashed line shows the trajectory in the absence of gravity. The point  $M, N, O$  and  $P$  correspond to time at  $t = 0, 1$  s,  $2$  s and  $3$  s, respectively. The lengths of  $X, Y$ , and  $Z$  are, respectively,

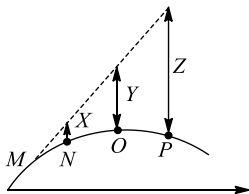

- a) 5 m, 10 m, 15 m                      b) 10 m, 20 m, 90 m                      c) 5 m, 20 m, 45 m                      d) 10 m, 20 m, 30 m
64. The path of one projectile as seen by an observer on another projectile is a/an:  
 a) Straight line                      b) Parabola                      c) Ellipse                      d) Circle
65. A projectile is fired with a velocity  $v$  at right angle to the slope inclined at an angle  $\theta$  with the horizontal. The range of the projectile along the inclined plane is

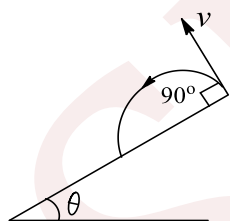

- a)  $\frac{2v^2 \tan \theta}{g}$                       b)  $\frac{v^2 \sec \theta}{g}$                       c)  $\frac{2v^2 \tan \theta \sec \theta}{g}$                       d)  $\frac{v^2 \sin \theta}{g}$
66. A ball thrown by one player reaches the other in 2 s. The maximum height attained by the ball above the point of projection will be about:  
 a) 2.5 m                      b) 5 m                      c) 7.5 m                      d) 10 m
67. The acceleration-velocity graph of a particle moving in a straight line is shown in Fig. Then, the slope of the velocity-displacement graph



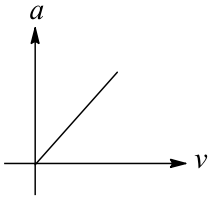

- a) Increases linearly  
b) Decreases linearly  
c) Is constant  
d) Increases parabolically
68. i. A hiker stands on the edge of a cliff 490 m above the ground and throws a stone horizontally with a speed of  $15 \text{ ms}^{-1}$ , the speed with which stone hits the ground is  
a)  $89.14 \text{ ms}^{-1}$   
b)  $79.14 \text{ ms}^{-1}$   
c)  $99.14 \text{ ms}^{-1}$   
d)  $109 \text{ ms}^{-1}$
69. A car is moving towards east with a speed of  $25 \text{ kmh}^{-1}$ . To the driver of the car, a bus appears to move towards north with a speed of  $25\sqrt{3} \text{ kmh}^{-1}$ . What is the actual velocity of the bus?  
a)  $50 \text{ kmh}^{-1}$ ,  $30^\circ$  E of N  
b)  $50 \text{ kmh}^{-1}$ ,  $30^\circ$  N of E  
c)  $25 \text{ kmh}^{-1}$ ,  $30^\circ$  E of N  
d)  $25 \text{ kmh}^{-1}$ ,  $30^\circ$  N of E
70. A particle  $P$  is sliding down a frictionless hemispherical bowl. It passes the point  $A$  at  $t = 0$ . At this instant of time, the horizontal component of its velocity  $v$ . A bead  $Q$  of the same mass as  $P$  is ejected from  $A$  to  $t = 0$  along the horizontal string  $AB$  (see figure) with the speed  $v$ . Friction between the bead and the string may be neglected. Let  $t_p$  and  $t_Q$  be the respective time taken by  $P$  and  $Q$  to reach the point  $B$ . Then
- 
- a)  $t_p < t_Q$   
b)  $t_p = t_Q$   
c)  $t_p > t_Q$   
d) All of these
71. A policeman moving on a highway with a speed of  $30 \text{ kmh}^{-1}$  fires a bullet at thief's car speeding away in the same direction with a speed of  $192 \text{ kmh}^{-1}$ . If the muzzle speed of the bullet is  $150 \text{ ms}^{-1}$ , with what speed does the bullet hit the thief's car?  
a)  $120 \text{ ms}^{-1}$   
b)  $90 \text{ ms}^{-1}$   
c)  $125 \text{ ms}^{-1}$   
d)  $105 \text{ ms}^{-1}$
72. A gun fires two bullets at  $60^\circ$  and  $30^\circ$  with the horizontal. The bullets strike at some horizontal distance. The ratio of the maximum height for the two bullets is in the ratio:  
a) 2 : 1  
b) 3 : 1  
c) 4 : 1  
d) 1 : 1
73. A boat is moving with a velocity  $3\hat{i} + 4\hat{j}$  with respect to ground. The water in the river is moving with a velocity  $-3\hat{i} - 4\hat{j}$  with respect to ground. The relative velocity of the boat with respect to water is  
a)  $8\hat{j}$   
b)  $-6\hat{i} - 8\hat{j}$   
c)  $6\hat{i} + 8\hat{j}$   
d)  $5\sqrt{2}$
74. The ceiling of a hall is 40 m high. For maximum horizontal distance, the angle at which the ball may be thrown with a speed of  $56 \text{ ms}^{-1}$  without hitting the ceiling of the hall is (Take  $g = 9.8 \text{ ms}^{-2}$ )  
a)  $25^\circ$   
b)  $30^\circ$   
c)  $45^\circ$   
d)  $60^\circ$
75. In the first part of question 56, the time taken to reach the maximum height will be decreased by  
a) 19%  
b) 5%  
c) 10%  
d) None of these
76. The acceleration of a particle which moves along the positive  $x$ -axis varies with its position as shown in Fig. If the velocity of the particle is  $0.8 \text{ ms}^{-1}$  at  $x = 0$ , then velocity of the particle at  $x = 1.4 \text{ m}$  is (in  $\text{ms}^{-1}$ )



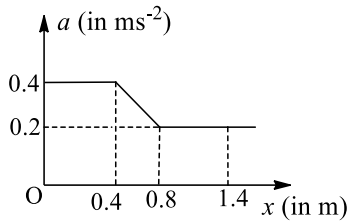

- a) 1.6                      b) 1.2                      c) 1.4                      d) None of these
77. For angles of projection of a projectile at angles  $(45 + \alpha)$  and  $(45 - \alpha)$ , the horizontal ranges described by the projectile are in the ratio of  
a) 2:1                      b) 1:2                      c) 1:1                      d) 2:3
78. The height  $y$  and the distance  $x$  along the horizontal plane of a projectile on a certain planet (with no surrounding atmosphere) are given by  $y = (8t - 5t^2)$  m and  $x = 6t$  m, where  $t$  is in seconds. The velocity with which the projectile is projected at  $t = 0$  is  
a)  $8 \text{ ms}^{-1}$                       b)  $6 \text{ ms}^{-1}$   
c)  $10 \text{ ms}^{-1}$                       d) Not obtainable from the data
79. A man swimming downstream overcomes a float at a point  $M$ . After travelling distance  $D$  he turned back and passed the float at a distance of  $D/2$  from the point  $M$ , then the ratio of speed of swimmer with respect to still water to the speed of the river will be  
a) 1                      b) 2                      c) 4                      d) 3
80. A body is moving in a circular path with a constant speed. It has  
a) A constant velocity  
b) A constant acceleration  
c) An acceleration of constant magnitude  
d) An acceleration which varies with time in magnitude
81. A point moves such that its displacement as a function of time is given by  $x^3 = t^3 + 1$ . Its acceleration as a function of time  $t$  will be  
a)  $\frac{2}{x^5}$                       b)  $\frac{2t}{x^5}$                       c)  $\frac{2t}{x^4}$                       d)  $\frac{2t^2}{x^5}$
82. The horizontal range and maximum height attained by a projectile are  $R$  and  $H$ , respectively. If a constant horizontal acceleration  $a = g/4$  is imparted to the projectile due to wind, then its horizontal range and maximum height will be  
a)  $(R + H), \frac{H}{2}$                       b)  $(R + \frac{H}{2}), 2H$                       c)  $(R + 2H), H$                       d)  $(R + H), H$
83. Raindrops are hitting the back of a man walking at a speed of  $5 \text{ kmh}^{-1}$ . If he now starts running in the same direction with a constant acceleration, the magnitude of the velocity of the rain with respect to him will  
a) Gradually increase                      b) Gradually decrease  
c) First decrease then increase                      d) First increase then decrease
84. A person takes an aim at a monkey sitting on a tree and fires a bullet. Seeing the smoke the monkey begins to fall freely then the bullet will  
a) Always hit the monkey  
b) Go above the monkey  
c) Go below the monkey  
d) Hit the monkey if the initial velocity of the bullet is more than a certain velocity
85. Two stones are projected with the same speed but making different angles with the horizontal. Their ranges are equal. If the angle of projection of one is  $\pi/3$  and its maximum height is  $h_1$  then the maximum height of the other will be



- a)  $3h_1$                       b)  $2h_1$                       c)  $h_1/2$                       d)  $h_1/3$
86. A projectile is projected with initial velocity  $(6\hat{i} + 8\hat{j})\text{ms}^{-1}$ . If  $g = 10 \text{ ms}^{-2}$ , then horizontal range is  
a) 4.8 m                      b) 9.6 m                      c) 19.2 m                      d) 14.0 m
87. An object moves along the  $x$ -axis. Its  $x$ -coordinates is given as a function of time as  $x = 7t - 3t^2$  m, where  $x$  is in metres and  $t$  is in seconds. Its average speed over the interval  $t = 0$  to  $t = 4$  s is  
a)  $5 \text{ ms}^{-1}$                       b)  $-5 \text{ ms}^{-1}$                       c)  $-\frac{169}{24} \text{ ms}^{-1}$                       d)  $\frac{169}{24} \text{ m/s}^{-1}$

88. Figure show that particle  $A$  is projected from point  $P$  with velocity  $u$  along the plane and simultaneously another particle  $B$  with velocity  $v$  at an angle  $\alpha$  with vertical. The particles collide at point  $Q$  on the plane. Then

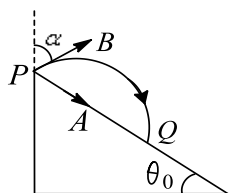

- a)  $v \sin(\alpha - \theta_0) = u$                       b)  $v \cos(\alpha - \theta_0) = u$                       c)  $v = u$                       d) None of these
89. A ball is thrown upwards and it returns to ground describing a parabolic path. Which of the following quantities remains constant throughout the motion?  
a) Kinetic energy of the ball                      b) Speed of the ball  
c) Horizontal component of velocity                      d) Vertical component of velocity
90. A ball rolls off the top of a stairway horizontally with a velocity of  $4.5 \text{ ms}^{-1}$ . Each step is 0.2 m high and 0.3 m wide. If  $g$  is  $10 \text{ ms}^{-2}$ , and the ball strikes the edge of  $n$ th step, then  $n$  is equal to  
a) 9                      b) 10                      c) 11                      d) 12
91. A person sitting in the rear end of a compartment throws a ball towards the front end. The ball follows a parabolic path. The train is moving with uniform velocity of  $20 \text{ ms}^{-1}$ . A person standing outside on the ground also observes the ball. How will the maximum heights ( $h_m$ ) attained and the ranges ( $R$ ) seen by the thrower and the outside observer compare each other?  
a) Same  $h_m$ , different  $R$                       b) Same  $h_m$ , and  $R$   
c) Different  $h_m$ , same  $R$                       d) Different  $h_m$ , and  $R$
92. A ball is thrown upwards at an angle of  $60^\circ$  to the horizontal. It falls on the ground at a distance of 90 m. If the ball is thrown with the same initial velocity at an angle  $30^\circ$ , it will fall on the ground at a distance of  
a) 120 m                      b) 90 m                      c) 60 m                      d) 30 m
93. A particle is moving in a circle of radius  $r$  centred at  $O$  with constant speed  $v$ . What is the change in velocity in moving from  $A$  to  $B$  ( $\angle AOB = 40^\circ$ )?  
a)  $2v \sin 20^\circ$                       b)  $4v \sin 40^\circ$                       c)  $2v \sin 40^\circ$                       d)  $v \sin 20^\circ$
94. A rifle shoots a bullet with a muzzle velocity of  $400 \text{ ms}^{-1}$  at a small target 400 m away. The height above the target at which the bullet must be aimed to hit the target is ( $g = 10 \text{ ms}^{-2}$ )  
a) 1 m                      b) 5 m                      c) 10 m                      d) 0.5 m
95. If position-time graph of a particle is sine curve as shown in Fig

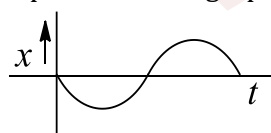

What will be its velocity-time graph?

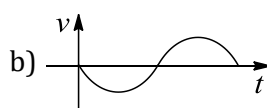
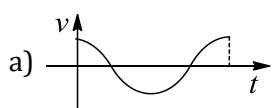

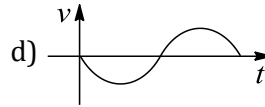
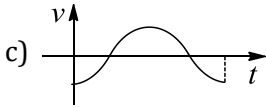

96. At a height 0.4 m from the ground, the velocity of a projectile in vector form is  $\vec{v} = (6\hat{i} + 2\hat{j})\text{ms}^{-1}$ . The angle of projection is  
 a)  $45^\circ$                                       b)  $60^\circ$                                       c)  $30^\circ$                                       d)  $\tan^{-1}(3/4)$
97. A ball of mass ( $m$ ) 0.5 kg is attached to the end of a string having length ( $L$ ) 0.5 m. The ball is rotated on a horizontal circular path about vertical axis. The maximum tension that the string can bear is 324 N. The maximum possible value of angular velocity of ball (in rad/s) is

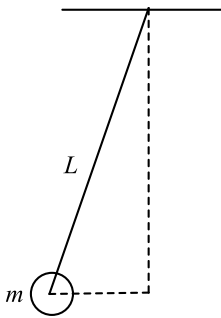

- a) 9    b) 18    c) 27    d) 36
98. A car is moving in a circular horizontal track of radius 10 m with a constant speed of 10 m/sec. A plumb bob is suspended from the roof of the car by a light rigid rod of length 1.00 m. The angle made by the rod with track is  
 a) Zero    b)  $30^\circ$     c)  $45^\circ$     d)  $60^\circ$
99. A man can swim in still water with a speed of 2  $\text{ms}^{-1}$ . If he wants to cross a river of water current speed  $\sqrt{3}\text{ms}^{-1}$  along shortest possible path, then in which direction should he swim?  
 a) At an angle  $120^\circ$  to the water current    b) At an angle  $150^\circ$  to the water current  
 c) At an angle  $90^\circ$  to the water current    d) None of these
100. A train of 150 m length is going toward north direction at a speed of 10  $\text{ms}^{-1}$ . A parrot flies at a speed of 5  $\text{ms}^{-1}$  towards south direction parallel to the railway track. The time taken by the parrot to cross the train is equal to  
 a) 12 s    b) 8 s    c) 15 s    d) 10 s
101. The maximum range of a projectile is 500 m. If the particle is thrown up a plane, which is inclined at an angle of  $30^\circ$  with the same speed, the distance covered by it along the inclined plane will be  
 a) 250 m    b) 500 m    c) 750 m    d) 1000 m
102. Rain is falling vertically with a velocity of 25  $\text{ms}^{-1}$ . A woman rides a bicycle with a speed of 10  $\text{ms}^{-1}$  in the north to south direction. What is the direction (angle with vertical) in which she should hold her umbrella to safe herself from rain?  
 a)  $\tan^{-1}(0.4)$     b)  $\tan^{-1}(1)$     c)  $\tan^{-1}(\sqrt{3})$     d)  $\tan^{-1}(2.6)$
103. A truck is moving with a constant velocity of 54  $\text{kmh}^{-1}$ . In which direction (angle with the direction of motion of truck) should a stone be projected up with a velocity of 20  $\text{ms}^{-1}$ , from the floor of the truck, so as to appear at right angles to the truck, for a person standing on earth?  
 a)  $\cos^{-1}\left(-\frac{3}{4}\right)$     b)  $\cos^{-1}\left(-\frac{1}{4}\right)$     c)  $\cos^{-1}\left(\frac{2}{3}\right)$     d)  $\cos^{-1}\left(\frac{3}{4}\right)$
104. The maximum height attained by a projectile is increased by 10%. Keeping the angle of projection constant, what is the percentage increase in the time of flight?  
 a) 5 %    b) 10 %    c) 20 %    d) 40 %



105. An airplane moving horizontally with a speed of  $180\text{kmh}^{-1}$  drops a food packet while flying at a height of 490 m. The horizontal range of the food packet is  $g = 9.8\text{ms}^{-2}$
- a) 180 m                      b) 980 m                      c) 500 m                      d) 670 m
106. A particle has been projected with a speed of  $20\text{ms}^{-1}$  at an angle of  $30^\circ$  with the horizontal. The time taken when the velocity vector becomes perpendicular to the initial velocity vector is
- a) 4 s                              b) 2 s  
c) 3 s                              d) Not possible in this case
107. A tube of length  $L$  is filled completely with an incompressible liquid of mass  $M$  and closed at both the ends. The tube is then rotated in a horizontal plane about one of its ends with a uniform angular velocity  $\omega$ . The force exerted by the liquid at the other end is
- a)  $\frac{ML\omega^2}{2}$                       b)  $ML\omega^2$                       c)  $\frac{ML\omega^2}{4}$                       d)  $\frac{ML^2\omega^2}{2}$
108. A body  $A$  is thrown vertically upwards with such a velocity that it reaches a maximum height of  $h$ . Simultaneously, another body  $B$  is dropped from height  $h$ . It strikes the ground and does not rebound. The velocity of  $A$  relative to  $B$  versus time graph is best represented by (upward direction is positive)

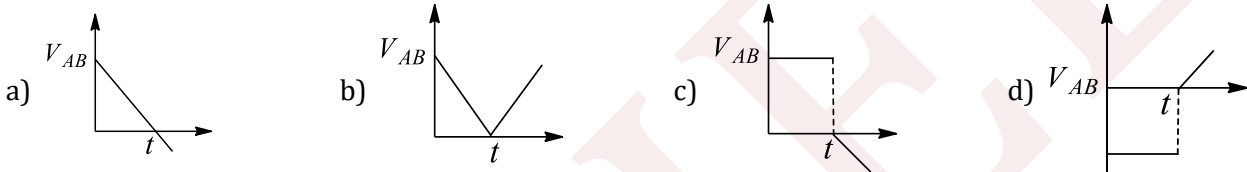

109. A projectile is thrown at an angle of  $40^\circ$  with the horizontal and its range is  $R_1$ . Another projectile is thrown at an angle  $40^\circ$  with the vertical and its range is  $R_2$ . What is the relation between  $R_1$  and  $R_2$ ?
- a)  $R_1 = R_2$                       b)  $R_1 = 2R_2$                       c)  $2R_1 = R_2$                       d)  $R_1 = 4R_2/5$
110. The ceiling of a hall is 40 m high. For maximum horizontal distance, the angle at which the ball may be thrown with a speed of  $56\text{ms}^{-1}$  without hitting the ceiling of the hall is, the maximum horizontal distance will be
- a)  $160\sqrt{3}\text{m}$   
b)  $140\sqrt{3}\text{m}$   
c)  $120\sqrt{3}\text{m}$   
d)  $100\sqrt{3}\text{m}$
111. A golfer standing on level ground hits a ball with a velocity of  $u = 52\text{ms}^{-1}$  at an angle  $\alpha$  above the horizontal. If  $\tan \alpha = 5/12$ , then the time for which the ball is at least 15 m above the ground will be (take  $g = 10\text{ms}^{-2}$ )
- a) 1 s                              b) 2 s                              c) 3 s                              d) 4 s
112. A plank is moving on ground with a velocity  $v$ , and a block is moving on the plank with respect to it with a velocity  $u$  w.r.t. plank as shown in fig. What is the velocity of block with respect to ground?

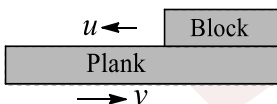

- a)  $v - u$  towards right                      b)  $v - u$  towards left  
c)  $u$  towards right                              d) None of these
113. A particle undergoes uniform circular motion. About which point on the plane of the circle, will the angular momentum of the particle remain conserved?
- a) center of the circle                              b) on the circumference of the circle  
c) inside the circle                                      d) outside the circle



114. A particle is moving along a circular path. The angular velocity, linear velocity, angular acceleration, and centripetal acceleration of the particle at any instant respectively are  $\vec{\omega}$ ,  $\vec{v}$ ,  $\vec{\alpha}$ , and  $\vec{a}_c$ . Which of the following relations is not correct?

- a)  $\vec{\omega} \perp \vec{v}$                       b)  $\vec{\omega} \perp \vec{\alpha}$                       c)  $\vec{\omega} \perp \vec{a}_c$                       d)  $\vec{v} \perp \vec{a}_c$

115. Two trains, which are moving along different tracks in opposite directions, are put on the same track due to a mistake. Their drivers, on noticing the mistake, start slowing down the trains when the trains are 300 m apart. Graphs given below show their velocities as function of time as the trains slow down. The separation between the trains when both have stopped is

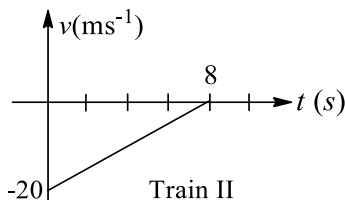
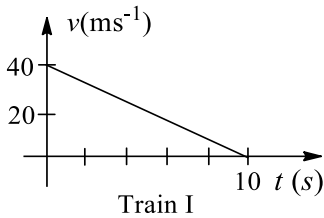

- a) 120 m                      b) 280 m                      c) 60 m                      d) 20 m

116. A man swims from a point A on one bank of a river of width 100 m. When he swims perpendicular to the water current, he reaches the other bank 50 m downstream. The angle to the bank at which he should swim, to reach the directly opposite point B on the other bank is

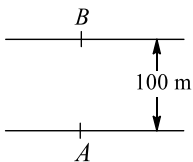

- a)  $10^\circ$  upstream                      b)  $20^\circ$  upstream                      c)  $30^\circ$  upstream                      d)  $60^\circ$  upstream

117. A particle of mass  $m$  is moving in a circular path of constant radius  $r$  such that its centripetal acceleration  $a_c$  is varying with time  $t$  as,  $a_c = k^2 r t^2$ , The power delivered to the particle by the forces acting on it is

- a)  $2\pi m k^2 r^2 t$                       b)  $m k^2 r^2 t$                       c)  $\frac{m k^4 r^2 t^5}{3}$                       d) Zero

118. The equation of motion of a projectile is  $y = 12x - \frac{3}{4}x^2$

The horizontal component of velocity is  $3 \text{ ms}^{-1}$ . What is the range of the projectile?

- a) 18 m                      b) 16 m                      c) 12 m                      d) 21.6 m

119. In the second part of question 56, the time taken to return to the ground from the maximum height

- a) Is almost same as in the absence of friction                      b) Decreases by 1%  
c) Increases by 1%                      d) Increases by 11%

120. At the top of the trajectory of a projectile, the acceleration is

- a) Maximum                      b) Minimum                      c) Zero                      d)  $g$

121. Two particles are projected simultaneously from the same point, with the same speed, in the same vertical plane, and at different angles with the horizontal in a uniform gravitational field acting vertically downwards. A frame of reference is fixed to one particle. The position vector of the other particle, as observed from this frame, is  $\vec{r}$ . Which of the following statements is correct?

- a)  $\vec{r}$  is a constant vector



- b)  $\vec{r}$  changes in magnitude as well as direction with time  
 c) The magnitude of  $\vec{r}$  increases linearly with time: its direction does not change  
 d) The direction of  $\vec{r}$  changes with time: its magnitude may or may not change, depending on the angles of projection

122. An aircraft executes a horizontal loop of radius 1 km with a steady speed of  $900 \text{ kmh}^{-1}$ . Find its centripetal acceleration

- a)  $62.5 \text{ ms}^{-2}$                       b)  $30 \text{ ms}^{-2}$                       c)  $32.5 \text{ ms}^{-2}$                       d)  $72.5 \text{ ms}^{-2}$

123. A bob of mass  $M$  is suspended by a massless string of length  $L$ . The horizontal velocity  $v$  at position  $A$  is just sufficient to make it reach the point  $B$ . The angle  $\theta$  at which the speed of the bob is half of that at  $A$ , satisfies

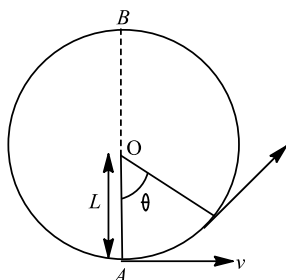

- a)  $\theta = \frac{\pi}{4}$                       b)  $\frac{\pi}{4} < \theta < \frac{\pi}{2}$                       c)  $\frac{\pi}{2} < \theta < \frac{3\pi}{4}$                       d)  $\frac{3\pi}{4} < \theta < \pi$

124. At the uppermost point of a projectile, its velocity and acceleration are at an angle of

- a)  $0^\circ$                       b)  $45^\circ$                       c)  $90^\circ$                       d)  $180^\circ$

125. A ball is thrown from a point with a speed  $v_0$  at an angle of projection  $\theta$ . From the same point and at the same instant, a person starts running with a constant speed  $v_0/2$  to catch the ball. Will the person be able to catch the ball? If yes, what should be the angle of projection?

- a) Yes,  $60^\circ$                       b) Yes,  $30^\circ$                       c) No                      d) Yes,  $45^\circ$

126. A particle is moving with velocity of  $4 \text{ ms}^{-1}$  along positive  $x$ -direction. An acceleration of  $1 \text{ ms}^{-2}$  is acted on the particle along negative  $x$ -direction. Find the distance travelled by the particle in 10 s

- a) 10 m                      b) 26 m                      c) 16 m                      d) 8 m

127. Rain, driven by the wind, falls on a railway compartment with a velocity of  $20 \text{ ms}^{-1}$ , at an angle of  $30^\circ$  to the vertical. The train moves, along the direction of wind flow, at a speed of  $108 \text{ kmh}^{-1}$ . Determine the apparent velocity of rain for a person sitting in the train

- a)  $20\sqrt{7} \text{ ms}^{-1}$                       b)  $10\sqrt{7} \text{ ms}^{-1}$                       c)  $15\sqrt{7} \text{ ms}^{-1}$                       d)  $10\sqrt{7} \text{ kmh}^{-1}$

128. A projectile is thrown in the upward direction making an angle of  $60^\circ$  with the horizontal direction with a velocity of  $150 \text{ ms}^{-1}$ . Then the time after which its inclination with the horizontal is  $45^\circ$  is

- a)  $15(\sqrt{3} - 1) \text{ s}$                       b)  $15(\sqrt{3} + 1) \text{ s}$                       c)  $7.5(\sqrt{3} - 1) \text{ s}$                       d)  $7.5(\sqrt{3} + 1) \text{ s}$

129. Consider a disc rotating in the horizontal plane with a constant angular speed  $\omega$  about its centre  $O$ . The disc has a shaded region on one side of the diameter and an unshaded region on the other side as shown in the figure. When the disc is in the orientation as shown, two pebbles  $P$  and  $Q$  are simultaneously projected at an angle towards  $R$ . The velocity of projection is in the  $y - z$  plane and is same for both pebbles with respect to the disc. Assume that (i) they land back on the disc before the disc has completed  $\frac{1}{8}$  rotation. (ii) their range is less than half the disc radius, and (iii)  $\omega$  remains constant throughout. Then

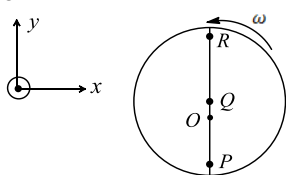

- a)  $P$  lands in the shaded region and  $Q$  in the unshaded region



- b)  $P$  lands in the unshaded region and  $Q$  in the shaded region  
 c) Both  $P$  and  $Q$  land in the unshaded region  
 d) Both  $P$  and  $Q$  land in the shaded region
130. A shot is fired from a point at a distance of 200 m from the foot of a tower 100 m high so that it just passes over it horizontally. The direction of shot with horizontal is:  
 a)  $30^\circ$                                       b)  $45^\circ$                                       c)  $60^\circ$                                       d)  $70^\circ$
131. Rain appears to fall vertically to a man walking at  $3 \text{ kmh}^{-1}$ , but when he changes his speed to double, the rain appears to fall at  $45^\circ$  with vertical. Study the following statements and find which of them are correct
- Velocity of rain is  $2\sqrt{3} \text{ kmh}^{-1}$
  - The angle of fall of rain (with vertical) is  $\theta = \tan^{-1} \left( \frac{1}{\sqrt{2}} \right)$
  - The angle of fall of rain (with vertical) is  $\theta = \sin^{-1} \left( \frac{1}{\sqrt{2}} \right)$
  - Velocity of rain is  $3\sqrt{2} \text{ kmh}^{-1}$
- a) Statements (i) and (ii) are correct                                      b) Statements (i) and (iii) are correct  
 c) Statements (iii) and (iv) are correct                                      d) Statements (ii) and (iv) are correct
132. A particle starts moving rectilinearly at time  $t = 0$  such that its velocity  $v$  changes with time  $t$  according to the equation  $v = t^2 - t$ , where  $t$  is in seconds and  $v$  is in  $\text{ms}^{-1}$ . The time interval for which the particle retards (i.e. magnitude of velocity decreases) is  
 a)  $t < 1/2$                                       b)  $1/2 < t < 1$                                       c)  $t > 1$                                       d)  $t < 1/2$  and  $t > 1$
133. If the time of flight of a projectile is doubled, what happens to the maximum height attained?  
 a) Halved                                      b) Remains unchanged                                      c) Doubled                                      d) Become four times
134. An object is subjected to the acceleration  $a = 4 + 3v$ . It is given that the displacement  $S = 0$ , when  $v = 0$ . The value of displacement when  $v = 2 \text{ ms}^{-1}$  is  $[\ln(0.4) = -0.9]$   
 a) 0.52 m                                      b) 0.27 m                                      c) 0.39 m                                      d) 0.65 m
135. A body is projected up along a smooth inclined plane with velocity  $u$  from the point  $A$  as shown in Fig. The angle of inclination is  $45^\circ$  and the top is connected to a well of diameter 40 m. If the body just manages to cross the well, what is the value of  $u$ ? Length of inclined plane is  $20\sqrt{2} \text{ m}$

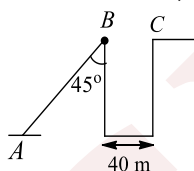

- a)  $40 \text{ ms}^{-1}$                                       b)  $40\sqrt{2} \text{ ms}^{-1}$                                       c)  $20 \text{ ms}^{-1}$                                       d)  $20\sqrt{2} \text{ ms}^{-1}$
136. A particle is thrown at time  $t = 0$  with a velocity of  $10 \text{ ms}^{-1}$  at an angle  $60^\circ$  with the horizontal from a point on an inclined plane, making an angle of  $30^\circ$  with the horizontal. The time when the velocity of the projectile becomes parallel to the incline is

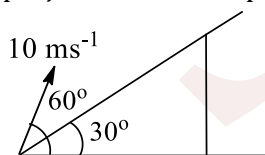

- a)  $\frac{2}{\sqrt{3}} \text{ s}$                                       b)  $\frac{1}{\sqrt{3}} \text{ s}$                                       c)  $\sqrt{3} \text{ s}$                                       d)  $\frac{1}{2\sqrt{3}} \text{ s}$
137. The maximum height attained by a projectile is increased by 5%. Keeping the angle of projection constant, what is the percentage increase in horizontal range?  
 a) 5 %                                      b) 10 %                                      c) 15 %                                      d) 20 %



138. The figure shows the velocity and acceleration of a point line body at the initial moment of its motion. The acceleration vector of the body remains constant. The minimum radius of curvature of trajectory of the body is

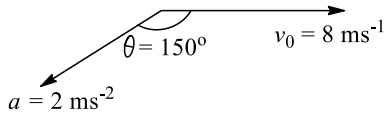

- a) 2 m                      b) 3 m                      c) 8 m                      d) 16 m
139. A body is projected at an angle of  $30^\circ$  with the horizontal and with a speed of  $30 \text{ ms}^{-1}$ . What is the angle with the horizontal after 1.5 s? ( $g = 10 \text{ ms}^{-2}$ )
- a)  $0^\circ$                       b)  $30^\circ$                       c)  $60^\circ$                       d)  $90^\circ$
140. In the above problem, what is the angle of projection with horizontal?
- a)  $\tan^{-1}(1/4)$                       b)  $\tan^{-1}(4/3)$                       c)  $\tan^{-1}(3/4)$                       d)  $\tan^{-1}(1/2)$
141. Two particles A and B are moving along straight line, whose position-time graph is shown in Fig. Determine the instant (approx) when both are moving with the same velocity

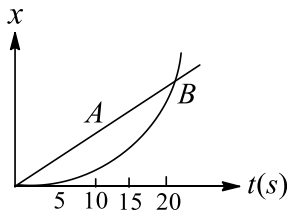

- a) 17 s                      b) 12 s                      c) 6 s                      d) No where
142. In first part of the problem 28, change in speed is
- a)  $u \cos \theta$                       b)  $u$                       c)  $u \sin \theta$                       d)  $(u \cos \theta - u)$
143. i. A hiker stands on the edge of a cliff 490 m above the ground and throws a stone horizontally with a speed of  $15 \text{ ms}^{-1}$ , the vertical component of the velocity on hitting the ground is
- a)  $79 \text{ ms}^{-1}$                       b)  $89 \text{ ms}^{-1}$                       c)  $98 \text{ ms}^{-1}$                       d)  $108 \text{ ms}^{-1}$
144. A body of mass  $m$  is projected horizontally with a velocity  $v$  from the top of a tower of height  $h$  and it reaches the ground at a distance  $x$  from the foot of the tower. If a second body of mass  $2m$  is projected horizontally from the top of a tower of height  $2h$ , it reaches the ground at a distance  $2x$  from the foot of the tower. The horizontal velocity of the second body is
- a)  $v$                       b)  $2v$                       c)  $\sqrt{2}v$                       d)  $v/2$
145. The speed of a projectile at its highest point is  $v_1$  and at the point half the maximum height is  $v_2$ . If  $\frac{v_1}{v_2} = \sqrt{\frac{2}{5}}$ , then find the angle of projection
- a)  $45^\circ$                       b)  $30^\circ$                       c)  $37^\circ$                       d)  $60^\circ$
146. A platform is moving upwards with an acceleration of  $5 \text{ ms}^{-2}$ . At the moment when its velocity is  $u = 3 \text{ ms}^{-1}$ , a ball is thrown from it with a speed of  $30 \text{ ms}^{-1}$  w.r.t. platform  $\text{ms}^{-1}$  at an angle  $\theta = 30^\circ$  with horizontal. The time taken by the ball to return to the platform is
- a) 2 s                      b) 3 s                      c) 1 s                      d) 2.5 s
147. A grasshopper can jump a maximum distance 1.6 m. It spends negligible time on the ground. How far can it go in 10 s?
- a)  $5\sqrt{2}m$                       b)  $10\sqrt{2}m$                       c)  $20\sqrt{2}m$                       d)  $40\sqrt{2}m$
148. A body is projected with velocity  $v_1$  from the point A as shown in fig. At the same time another body is projected vertically upwards from B with velocity  $v_2$ . The point B lies vertically below the highest point of first particle. For both the bodies to collide,  $v_2/v_1$  should be



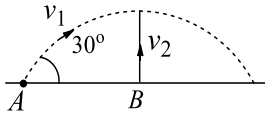

a) 2

b)  $\sqrt{\frac{3}{2}}$

c) 0.5

d) 1

149. When a particle is thrown horizontally, the resultant velocity of the projectile at any time  $t$  is given by

a)  $gt$

b)  $\frac{1}{2}gt^2$

c)  $\sqrt{u^2 + g^2t^2}$

d)  $\sqrt{u^2 - g^2t^2}$

150. A body is projected horizontally from the top of a tower with initial velocity  $18 \text{ ms}^{-1}$ . It hits the ground at angle  $45^\circ$ . What is the vertical component of velocity when strikes the ground?

a)  $9 \text{ ms}^{-1}$

b)  $9\sqrt{2} \text{ ms}^{-1}$

c)  $18 \text{ ms}^{-1}$

d)  $18\sqrt{2} \text{ ms}^{-1}$

151. i. If air resistance is not considered in a projectile motion, the horizontal motion takes place with

a) Constant velocity

b) Constant acceleration

c) Constant retardation

d) Variable velocity

152. Two tall buildings are 30 m apart. The speed with which a ball must be thrown horizontally from a window 150 m above the ground in one building so that it enters a window 27.5 m from the ground in the other building is

a)  $2 \text{ ms}^{-1}$

b)  $6 \text{ ms}^{-1}$

c)  $4 \text{ ms}^{-1}$

d)  $8 \text{ ms}^{-1}$

153. i. A hiker stands on the edge of a cliff 490 m above the ground and throws a stone horizontally with a speed of  $15 \text{ ms}^{-1}$ . The time taken by the stone to reach the ground is ( $g = 9.8 \text{ ms}^{-2}$ )

a) 10 s

b) 5 s

c) 12 s

d) 15 s

154. A motor boat is to reach at a point  $30^\circ$  upstream on the other side of a river flowing with velocity  $5 \text{ ms}^{-1}$ . The velocity of motor boat with respect to water is  $5\sqrt{3} \text{ ms}^{-1}$ . The driver should steer the boat at an angle

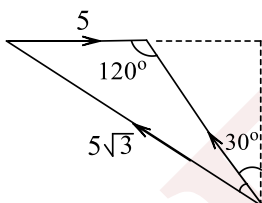

a)  $30^\circ$  w.r.t. the line of destination from the starting point

b)  $60^\circ$  w.r.t. normal to the bank

c)  $120^\circ$  w.r.t. stream direction

d) None of these

155. Velocity versus displacement graph of a particle moving in a straight line as shown in Fig

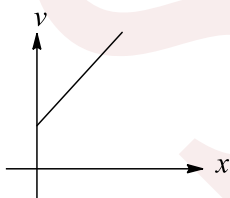

The acceleration of the particle

a) Is constant

b) Increases linearly with  $x$

c) Increases parabolically with  $x$

d) None of these

156. Shots are fired simultaneously from the top and bottom of a vertical cliff with the elevation  $\alpha = 30^\circ$ ,  $\beta = 60^\circ$ , respectively Fig. The shots strike an object simultaneously at the same point. If  $a = 30\sqrt{3} \text{ m}$  is the horizontal distance of the object from the cliff, then the height  $h$  of the cliff is



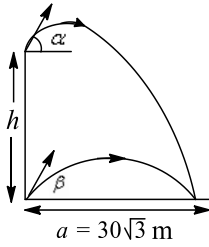

- a) 30 m                      b) 45 m                      c) 60 m                      d) 90 m
157. Wind is blowing in the north direction at speed of  $2 \text{ ms}^{-1}$ , which causes the rain to fall at some angle with the vertical. With what velocity should a cyclist drive so that the rain appears vertical to him:  
a)  $2 \text{ ms}^{-1}$  south                      b)  $2 \text{ ms}^{-1}$  north                      c)  $4 \text{ ms}^{-1}$  west                      d)  $4 \text{ ms}^{-1}$  south
158. The angular velocity of a particle moving in a circle of radius 50 cm is increased in 5 min from 100 revolutions per minute to 400 revolutions per minute. Find the tangential acceleration of the particle  
a)  $60 \text{ ms}^{-2}$                       b)  $\pi/30 \text{ ms}^{-2}$                       c)  $\pi/15 \text{ ms}^{-2}$                       d)  $\pi/60 \text{ ms}^{-2}$
159. A body moving in a circle with a speed of  $1 \text{ ms}^{-1}$ . This speed increases at a constant rate of  $2 \text{ ms}^{-1}$  every second. Assume that the radius of the circle described is 25 m. The total acceleration of the body after 2 s is  
a)  $2 \text{ ms}^{-2}$                       b)  $25 \text{ ms}^{-2}$                       c)  $\sqrt{5} \text{ ms}^{-2}$                       d)  $\sqrt{7} \text{ ms}^{-2}$
160. At a distance of 500 m from the traffic light, brakes are applied to an automobile moving at a velocity of  $20 \text{ ms}^{-1}$ . The position of the automobile relative to traffic light 50 s after applying the brakes, if its acceleration is  $-0.5 \text{ ms}^{-2}$  is  
a) 125 m                      b) 375 m                      c) 400 m                      d) 100 m
161. An object is moving in the  $x$ - $y$  plane with the position as a function of time given by  $\vec{r} = x(t)\hat{i} + y(t)\hat{j}$ . Point  $O$  is at  $x = 0, y = 0$ . The object is definitely moving towards  $O$  when,  
a)  $v_x > 0, v_y > 0$                       b)  $v_x < 0, v_y < 0$                       c)  $xv_x + 0, yv_y < 0$                       d)  $xv_x + yv_y > 0$
162. A projectile has a time of flight  $T$  and range  $R$ . If the time of flight is doubled, keeping the angle of projection same, what happens to the range?  
a)  $R/4$                       b)  $R/2$                       c)  $2R$                       d)  $4R$
163. The range  $R$  of projectile is same when its maximum heights are  $h_1$  and  $h_2$ . What is the relation between  $R, h_1$ , and  $h_2$ ?  
a)  $R = \sqrt{h_1 h_2}$                       b)  $R = \sqrt{2h_1 h_2}$                       c)  $R = 2\sqrt{h_1 h_2}$                       d)  $R = 4\sqrt{h_1 h_2}$
164. The ratio of the distance carried away by the water current, downstream, in crossing a river, by a person, making same angle with downstream and upstream is 2:1. The ratio of the speed of person to the water current cannot be less than  
a)  $1/3$                       b)  $4/5$                       c)  $2/5$                       d)  $4/3$
165. Two particles  $A$  and  $B$  are placed as shown in Fig. The particle  $A$ , on the top of tower, is projected horizontally

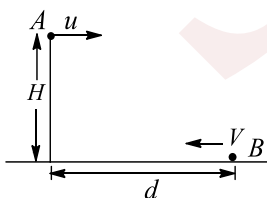

With a velocity  $u$  and particle  $B$  is projected along the surface towards the tower, simultaneously. If both particles meet each other, then the speed of projection of particle  $B$  is [ignore any friction]

- a)  $d\sqrt{\frac{g}{2H}} - u$                       b)  $d\sqrt{\frac{g}{2H}}$                       c)  $d\sqrt{\frac{g}{2H}} + u$                       d)  $u$



166. A swimmer wishes to cross a 500 m river flowing at  $5 \text{ kmh}^{-1}$ . His speed with respect to water is  $3 \text{ kmh}^{-1}$ . The shortest possible time to cross the river is  
 a) 10 min                      b) 20 min                      c) 6 min                      d) 7.5 min
167. A car is moving horizontally along a straight line with a uniform velocity of  $25 \text{ ms}^{-1}$ . A projectile is to be fired from this car in such a way that it will return to it after it has moved 100 m. The speed of the projection must be  
 a)  $10 \text{ ms}^{-1}$                       b)  $20 \text{ ms}^{-1}$                       c)  $15 \text{ ms}^{-1}$                       d)  $25 \text{ ms}^{-1}$
168. A body has an initial velocity of  $3 \text{ m/s}$  and has an acceleration of  $1 \text{ ms}^{-2}$  normal to the direction of the initial velocity. Then its velocity 4 s after the start is  
 a)  $7 \text{ ms}^{-1}$  along the direction of initial velocity  
 b)  $7 \text{ ms}^{-1}$  along the normal to the direction of initial velocity  
 c)  $7 \text{ ms}^{-1}$  midway between the two directions  
 d)  $5 \text{ ms}^{-1}$  at an angle  $\tan^{-1}(4/3)$  with the direction of initial velocity
169. Two boys  $P$  and  $Q$  are playing on a river bank.  $P$  plans to swim across the river directly and come back.  $Q$  plans to swim downstream by a length equal to the width of the river and then come back. Both of them bet each other, claiming that the boy succeeding in less time will win. Assuming the swimming rate of both  $P$  and  $Q$  to be the same, it can be concluded that  
 a)  $P$  wins                                      b)  $Q$  wins  
 c) A draw takes place                      d) Nothing certain can be stated
170. A bird is flying towards north with a velocity  $40 \text{ kmh}^{-1}$  and a train is moving with velocity  $40 \text{ kmh}^{-1}$  towards east. What is the velocity of the bird noted by a man in the train?  
 a)  $40\sqrt{2} \text{ kmh}^{-1} \text{ N} - \text{E}$                       b)  $40\sqrt{2} \text{ kmh}^{-1} \text{ S} - \text{E}$   
 c)  $40\sqrt{2} \text{ kmh}^{-1} \text{ N} - \text{W}$                       d)  $40\sqrt{2} \text{ kmh}^{-1} \text{ S} - \text{W}$
171. A ball thrown by one player reaches the other in 2 s. The maximum height attained by the ball above the point of projection will be about  
 a) 2.5 m                      b) 5 m                      c) 7.5 m                      d) 10 m
172. The acceleration of an object starting from rest and moving along a straight line is shown in Fig

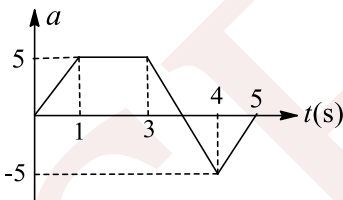

Other than at  $t = 0$ , when is the velocity of the object equal to zero?

- a) At  $t = 3.5 \text{ s}$                                       b) During interval from 1 s to 3 s  
 c) At  $t = 5 \text{ s}$                                       d) At no other time on this graph
173. A ball rolls off the top of a staircase with a horizontal velocity  $u \text{ ms}^{-1}$ . If the steps are  $h$  metre high and  $b$  metre wide, the ball will hit the edge of the  $n$ th step, if  
 a)  $n = \frac{2hu}{gb^2}$                       b)  $n = \frac{2hu^2}{gb}$                       c)  $n = \frac{2hu^2}{gb^2}$                       d)  $n = \frac{hu^2}{gb^2}$
174. Four persons  $K, L, M$  and  $N$  are initially at the corners of a square of side of length  $d$ . If every person starts moving, such that  $K$  is always headed towards  $L, L$  towards  $M, M$  is headed directly towards  $N$  and  $N$  towards  $K$ , then the four persons will meet after  
 a)  $\frac{d}{v} \text{ sec}$                       b)  $\frac{\sqrt{2}d}{v} \text{ sec}$                       c)  $\frac{d}{\sqrt{2}v} \text{ sec}$                       d)  $\frac{d}{2v} \text{ sec}$



175. Ship A is travelling with a velocity of  $5 \text{ kmh}^{-1}$  due east. A second ship is heading  $30^\circ$  east of north. What should be north with respect to the first ship?  
 a)  $10 \text{ kmh}^{-1}$                       b)  $9 \text{ kmh}^{-1}$                       c)  $8 \text{ kmh}^{-1}$                       d)  $7 \text{ kmh}^{-1}$
176. The point from where a ball is projected is taken as the origin of the coordinate axes. The  $x$  and  $y$  components of its displacement are given by  $x = 6t$  and  $y = 8t - 5t^2$ . What is the velocity of projection?  
 a)  $6 \text{ ms}^{-1}$                       b)  $8 \text{ ms}^{-1}$                       c)  $10 \text{ ms}^{-1}$                       d)  $14 \text{ ms}^{-1}$
177. A particle is moving along a straight line whose velocity displacement graph is shown in Fig

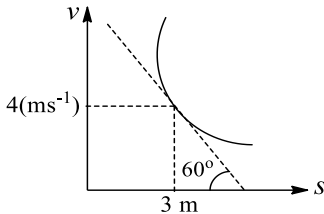

- What is the acceleration when displacement is  $3 \text{ m}$ ?  
 a)  $4\sqrt{3} \text{ ms}^{-2}$                       b)  $3\sqrt{3} \text{ ms}^{-2}$                       c)  $\sqrt{3} \text{ ms}^{-2}$                       d)  $4/\sqrt{3} \text{ ms}^{-2}$
178. Two paper screens A and B are separated by  $150 \text{ m}$ . A bullet pierces A and B. The hole in B is  $15 \text{ cm}$  below the hole in A. If the bullet is travelling horizontally at the time of hitting A, then the velocity of the bullet at A is ( $g = 10 \text{ ms}^{-2}$ )  
 a)  $100\sqrt{3} \text{ ms}^{-1}$                       b)  $200\sqrt{3} \text{ ms}^{-1}$                       c)  $300\sqrt{3} \text{ ms}^{-1}$                       d)  $500\sqrt{3} \text{ ms}^{-1}$
179. Two particles are thrown horizontally in opposite directions with velocities  $u$  and  $2u$  from the top of a high tower. The time after which their radius of curvature will be mutually perpendicular is  
 a)  $\sqrt{2} \frac{u}{g}$                       b)  $2 \frac{u}{g}$                       c)  $\frac{1}{\sqrt{2}} \frac{u}{g}$                       d)  $\frac{1}{2} \frac{u}{g}$
180. A ball is shown downwards from the edge of a very high cliff with an initial speed greater than terminal speed. Mark the correct statement about its acceleration  
 a) It is always acting in the upward direction  
 b) It is always acting in the downward direction  
 c) Initially, it is acting in upward direction and then it becomes zero  
 d) Initially, it is acting in upward direction and then it attains a non-zero constant value in the downward direction
181. The speed of a projectile at its maximum height is  $\sqrt{3}/2$  times its initial speed. If the range of the projectile is  $P$  times the maximum height attained by it.  $P$  is equal to  
 a)  $4/3$                       b)  $2\sqrt{3}$                       c)  $4\sqrt{3}$                       d)  $3/4$
182. An elevator is moving upwards with constant acceleration. The broken curve shows the position  $y$  of the ceiling of the elevator as a function of time  $t$ . A bolt breaks loose and drops from the ceiling

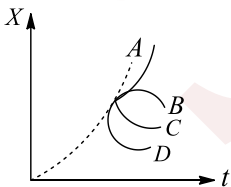

- Which curve best represents the position of the bolt as a function of time?  
 a) A                      b) B                      c) C                      d) D
183. A projectile is given an initial velocity of  $\hat{i} + 2\hat{j}$ . The cartesian equation of its path is ( $g = 10 \text{ ms}^{-2}$ )  
 a)  $y = 2x - 5x^2$                       b)  $y = x - 5x^2$                       c)  $4y = 2x - 5x^2$                       d)  $y = 2x - 25x^2$
184. A man holds an umbrella at  $30^\circ$  with the vertical to keep himself dry. He, then, runs at a speed of  $10 \text{ ms}^{-1}$ , and find the rain drops to be hitting vertically. Study the following statements and find the correct options



- I. Velocity of rain w.r.t. Earth is  $20 \text{ ms}^{-1}$   
 II. Velocity of rain w.r.t. man is  $10\sqrt{3} \text{ ms}^{-1}$   
 III. Velocity of rain w.r.t. Earth is  $30 \text{ ms}^{-1}$   
 IV. Velocity of rain w.r.t. man is  $10\sqrt{2} \text{ ms}^{-1}$

- a) Statements (i) and (ii) are correct  
 b) Statements (i) and (iii) are correct  
 c) Statements (iii) and (iv) are correct  
 d) Statements (ii) and (iv) are correct

185. A projectile will cover same horizontal distance when the initial angles of projection are:

- a)  $20^\circ, 60^\circ$                       b)  $20^\circ, 50^\circ$                       c)  $20^\circ, 40^\circ$                       d)  $20^\circ, 70^\circ$

186. If a stone is to hit at a point which is at a distance  $d$  away and at a height  $h$  fig above the point from where the stone starts, then what is the value of initial speed  $u$  if the stone is launched at an angle  $\theta$ ?



- a)  $\frac{g}{\cos \theta} \sqrt{\frac{d}{2(d \tan \theta - h)}}$     b)  $\frac{d}{\cos \theta} \sqrt{\frac{g}{2(d \tan \theta - h)}}$     c)  $\sqrt{\frac{gd^2}{h \cos^2 \theta}}$     d)  $\sqrt{\frac{gd^2}{(d - h)}}$

### Multiple Correct Answers Type

187. Which of the following statements is/are correct

- a) The magnitude of the vector  $3\hat{i} + 4\hat{j}$  is 5  
 b) A force  $(3\hat{i} + 4\hat{j})\text{N}$  acting on a particle causes a displacement  $6\hat{j}$ . The work done by the force is 30 N  
 c) If  $\vec{A}$  and  $\vec{B}$  represent two adjacent sides of a parallelogram, then  $|\vec{A} \times \vec{B}|$  give the area of that parallelogram  
 d) A force has magnitude 20 N. Its component in a direction making an angle  $60^\circ$  with the force is  $10\sqrt{3}$  N

188. Two projectiles A and B are projected with same speed at angles  $15^\circ$  and  $75^\circ$  respectively to the horizontal and have same horizontal range. If  $h$  be the maximum height and  $T$  total time of flight of a projectile, then

- a)  $h_A > h_B$                       b)  $h_A < h_B$                       c)  $T_A < T_B$                       d)  $T_A > T_B$

189. If  $T$  is the total time of flight,  $h$  is the maximum height and  $R$  is the range for horizontal motion, the  $x$  and  $y$  co-ordinates of projectile motion and time  $t$  are related as

- a)  $y = 4h \left(\frac{t}{T}\right) \left(1 - \frac{t}{T}\right)$                       b)  $y = 4h \left(\frac{x}{R}\right) \left(1 - \frac{x}{R}\right)$   
 c)  $y = 4h \left(\frac{T}{t}\right) \left(1 - \frac{T}{t}\right)$                       d)  $y = 4h \left(\frac{R}{x}\right) \left(1 - \frac{R}{x}\right)$

190. A particle moves along a circle with a constant speed. If  $a$  is acceleration and  $E$  is kinetic energy of the particle, then

- a)  $a$  is constant                      b)  $E$  is constant                      c)  $a$  is variable                      d)  $E$  is variable

191. A ball is thrown upwards into air with a speed greater than its terminal speed. It lands at the same place from where it was thrown. Mark the correct statement(s)

- a) It acquires terminal speed before it gets to the highest point of the trajectory  
 b) Before reaching the highest point of trajectory, its speed is continuously decreasing  
 c) During the entire flight, the force of air resistance is greatest just after it is thrown  
 d) The magnitude of net force experienced by the ball is maximum just after it is thrown

192. All the particles thrown with same initial velocity would strike the ground



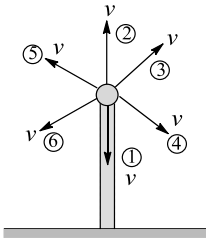

- a) With same speed  
b) Simultaneously  
c) Time would be least for the particle thrown with velocity  $v$  downward i.e., particle 1  
d) Time would be maximum for the particle 2
193. A particle is moving in  $xy$ -plane with  $y = x/2$  and  $v_x = 4 - 2t$ . Choose the correct options  
a) Initial velocities in  $x$  and  $y$  directions are negative  
b) Initial velocities in  $x$  and  $y$  directions are positive  
c) Motion is first retarded, then accelerated  
d) Motion is first accelerated, then retarded
194. A particle is acted upon by a force of constant magnitude which is always perpendicular to the velocity of the particle. The motion of the particle takes place in a plane. It follows that  
a) Velocity is constant  
b) Acceleration is constant  
c) Kinetic energy is constant  
d) It moves in a circular path
195. A ball is rolled off the edge of a horizontal table at a speed of  $4 \text{ m/second}$ . It hits the ground after  $0.4 \text{ second}$ . Which statement given below is true  
a) It hits the ground at a horizontal distance  $1.6 \text{ m}$  from the edge of the table  
b) The speed with which it hits the ground is  $4.0 \text{ m/second}$   
c) Height of the table is  $0.8 \text{ m}$   
d) It hits the ground at an angle of  $60^\circ$  to the horizontal
196. Ship  $A$  is located  $4 \text{ km}$  north and  $3 \text{ km}$  east of ship  $B$ . Ship  $A$  has a velocity of  $20 \text{ kmh}^{-1}$  towards the south and ship  $B$  is moving at  $40 \text{ kmh}^{-1}$  in a direction  $37^\circ$  north of east. Take  $x$  and  $y$ -axes along east and north directions, respectively  
a) Velocity of  $A$  relative to  $B$  is  $-32\hat{i} - 44\hat{j}$   
Position of  $A$  relative to  $B$  as a function of time is given by  
b)  $\vec{r}_{AB} = (3 - 32t)\hat{i} + (4 - 44t)\hat{j}$   
where  $t = 0$  when the ships are in position described above  
c) Velocity of  $B$  relative to  $A$  is  $-32\hat{i} - 44\hat{j}$   
d) At some moment  $A$  will be west of  $B$
197. A car moves on a circular road describing equal angles about the centre in equal intervals of time. Which of the following statements about the velocity of car not true?  
a) Velocity is constant  
b) Magnitude of velocity is constant but the direction changes  
c) Both magnitude and direction of velocity change  
d) Velocity is directed towards the centre of circle
198. If the two vectors  $\vec{A} = 2\hat{i} + 3\hat{j} + 4\hat{k}$  and  $\vec{B} = \hat{i} + 2\hat{j} - n\hat{k}$  are perpendicular then the value of  $n$  is  
a) 1  
b) 2  
c) 3  
d) 4
199. A particle moves in a circle of radius  $20 \text{ cm}$ . Its linear speed is given by  $v = 2t$  where  $t$  is in seconds and  $v$  in  $\text{ms}^{-1}$ . Then  
a) The radial acceleration at  $t = 2 \text{ s}$  is  $80 \text{ ms}^{-2}$   
b) Tangential acceleration  $t = 2 \text{ s}$  is  $2 \text{ ms}^{-2}$



- c) Net acceleration at  $t = 2$  s is greater than  $80 \text{ ms}^{-2}$   
 d) Tangential acceleration remains constant in magnitude
200. A particle is moving eastwards with a velocity of  $5 \text{ ms}^{-1}$ . In 10 s the velocity changes to  $5 \text{ ms}^{-1}$  northwards. The average acceleration in this time is  
 a) Zero  
 b)  $1/\sqrt{2} \text{ ms}^{-2}$  towards north-west  
 c)  $1/2 \text{ ms}^{-2}$  towards north-west  
 d)  $1/2 \text{ ms}^{-2}$  towards north
201. Suppose two particles 1 and 2 are projected in vertical plane simultaneously

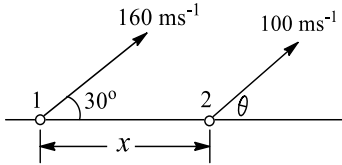

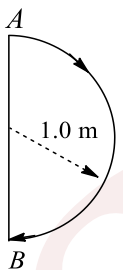
- Their angles of projection are  $30^\circ$  and  $\theta$  respectively, with the horizontal. Let them collide after a time  $t$  in air. Then  
 a)  $\theta = \sin^{-1}(4/5)$  and they will have same speed just before the collision  
 b)  $\theta = \sin^{-1}(4/5)$  and they will have different speed just before the collision  
 c)  $x < 1280\sqrt{3} - 960$  m  
 d) It is possible that the particles collide when both of them are at their highest point
202. If  $a_r$  and  $a_t$  represent radial and tangential acceleration, the motion of a particle will be circular if  
 a)  $a_r = 0$  and  $a_t = 0$   
 b)  $a_r = 0$  but  $a_t \neq 0$   
 c)  $a_r \neq 0$  and  $a_t = 0$   
 d)  $a_r \neq 0$  and  $a_t \neq 0$
203. An object moves with constant acceleration  $\vec{a}$ . Which of the following expressions is/are also constant?  
 a)  $\frac{d|\vec{v}|}{dt}$   
 b)  $\left| \frac{d\vec{v}}{dt} \right|$   
 c)  $\frac{d(v^2)}{dt}$   
 d)  $\frac{d\left(\frac{\vec{v}}{|\vec{v}|}\right)}{dt}$
204. In 1.0 s, a particle goes from point A to point B, moving in a semicircle of radius 1.0 m. The magnitude of the average velocity is  
  
 a)  $3.14 \text{ ms}^{-1}$   
 b)  $2.0 \text{ ms}^{-1}$   
 c)  $1.0 \text{ ms}^{-1}$   
 d) Zero
205. The coordinates of a particle moving in a plane are given by  $x(t) = a \cos(pt)$  and  $y(t) = b \sin(pt)$ , where  $a, b (< a)$ , and  $p$  are positive constants of appropriate dimensions. Then  
 a) The path of the particle is an ellipse  
 b) The velocity and acceleration of the particle are normal to each other at  $t = \pi/2p$   
 c) The acceleration of the particle is always directed towards a focus  
 d) The distance travelled by the particle in time interval  $t = 0$  to  $t = \pi/2p$  is  $a$
206. If a body placed at the origin is acted upon by a force  $\vec{F} = (\hat{i} + \hat{j} + \sqrt{2}\hat{k})$ , then which of the following statements are correct?  
 a) Magnitude of  $F$  is  $(2+\sqrt{2})$   
 b) Magnitude of  $F$  is 2  
 c)  $\vec{F}$  makes an angle of  $45^\circ$  with the Z-axis  
 d)  $\vec{F}$  makes an angle of  $30^\circ$  with the Z-axis



207. A particle of mass  $m$  moved on the  $x$ -axis as follows: it starts from rest  $t = 0$  from the point  $x = 0$ , and comes to rest at  $t = 1$  at the point  $x = 1$ . No other information is available about its motion at intermediate times ( $0 < t < 1$ ). If  $\alpha$  denotes the instantaneous acceleration of the particle, then
- $\alpha$  cannot remain positive for all  $t$  in the interval  $0 \leq t \leq 1$
  - $|\alpha|$  cannot exceed 2 at any point in its path
  - $|\alpha|$  must be  $\geq 4t$  at some point or points in its path
  - $\alpha$  must change sign during the motion, but no other assertion can be made with the information given
208. Mark the correct statement(s)
- A particle can have zero displacement and non-zero average velocity
  - A particle can have zero displacement and non-zero velocity
  - A particle can have zero acceleration and non-zero velocity
  - A particle can have zero velocity and non-zero acceleration
209. If  $A = 5$  units,  $B = 6$  units and  $|\vec{A} \times \vec{B}| = 15$  units, then what is the angle between  $\vec{A}$  and  $\vec{B}$ ?
- $30^\circ$
  - $60^\circ$
  - $90^\circ$
  - $150^\circ$
210. An object may have
- Varying speed without having varying velocity
  - Varying velocity without having varying speed
  - Non-zero acceleration without having varying velocity
  - Non-zero acceleration without having varying speed
211. A stationary person observes that rain is falling vertically down at  $30 \text{ kmh}^{-1}$ . A cyclist is moving up on an inclined plane making an angle  $30^\circ$  with horizontal at  $10 \text{ kmh}^{-1}$ . In which direction should the cyclist hold his umbrella to prevent himself from the rain?
- At an angle  $\tan^{-1}\left(\frac{3\sqrt{3}}{5}\right)$  with inclined plane
  - At an angle  $\tan^{-1}\left(\frac{3\sqrt{3}}{5}\right)$  with horizontal
  - At an angle  $\tan^{-1}\left(\frac{\sqrt{3}}{7}\right)$  with inclined plane
  - At an angle  $\tan^{-1}\left(\frac{\sqrt{3}}{7}\right)$  with vertical
212. A river is flowing towards east with a velocity of  $5 \text{ ms}^{-1}$ . The boat velocity is  $10 \text{ ms}^{-1}$ . The boat crosses the river by shortest path, hence,
- The direction of boat's velocity is  $30^\circ$  west of north
  - The direction of boat's velocity is north-west
  - Resultant velocity is  $5\sqrt{3} \text{ ms}^{-1}$
  - Resultant velocity of boat is  $5\sqrt{2} \text{ ms}^{-1}$
213. At time  $t = 0$ , a car moving along a straight line has a velocity of  $16 \text{ ms}^{-1}$ . It slows with an acceleration of  $-0.5t \text{ ms}^{-2}$ , where  $t$  is in seconds. Mark the correct statement(s)
- The direction of velocity changes at  $t = 8 \text{ s}$
  - The distance travelled in  $4 \text{ s}$  is approximately  $59 \text{ m}$
  - The distance travelled by the particle in  $10 \text{ s}$  is  $94 \text{ m}$
  - The velocity at  $t = 10 \text{ s}$  is  $9 \text{ ms}^{-1}$
214. A particle is dropped from a tower in a uniform gravitational field at  $t = 0$ . The particle is blown over by a horizontal wind with constant velocity. Slope ( $m$ ) of trajectory of the particle with horizontal and its kinetic energy vary according to curves. Here,  $x$  is horizontal displacement and  $h$  is height of particle from ground at time  $t$

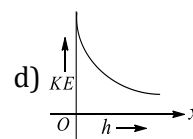
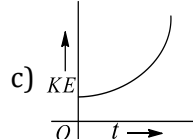
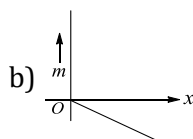
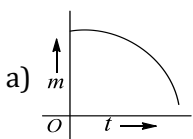

215. If vectors  $\vec{A}$  and  $\vec{B}$  are given by  $\vec{A} = 5\hat{i} + 6\hat{j} + 3\hat{k}$  and  $\vec{B} = 6\hat{i} - 2\hat{j} - 6\hat{k}$ . Which is/are of the following correct?



- a)  $\vec{A}$  and  $\vec{B}$  are mutually perpendicular
- b) Product of  $\vec{A} \times \vec{B}$  is the same  $\vec{B} \times \vec{A}$
- c) The magnitude of  $\vec{A}$  and  $\vec{B}$  are equal
- d) The magnitude of  $\vec{A} \cdot \vec{B}$  is zero

216. A heavy particle is projected with a velocity at an angle with the horizontal into a uniform gravitational field. The slope of the trajectory of the particle varies not according to which of the following curves?

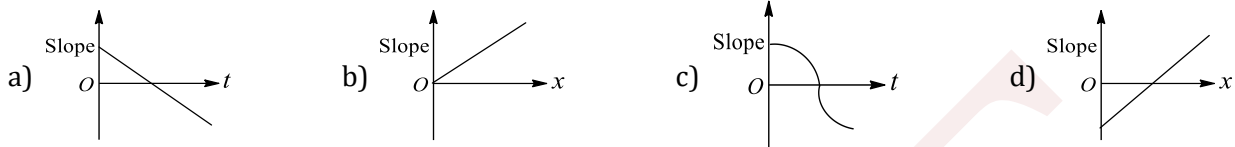

217. A train carriage move along the  $x$ -axis with a uniform acceleration  $\vec{a}$ . An observer  $A$  in the train sets a ball in motion on the frictionless floor of the carriage with the velocity  $\vec{u}$  relative to the carriage. The direction of  $\vec{u}$  makes an angle  $\theta$  with the  $x$ -axis. Let  $B$  be an observer standing on the ground outside the train. The subsequent path of the ball will be

- a) A straight line with respect to observer  $A$
- b) A straight line with respect to observer  $B$
- c) A parabola with respect to observer  $A$
- d) A parabola with respect to observer  $B$

218. From the top of a tower of height 200 m, a ball  $A$  is projected up with speed  $10 \text{ ms}^{-1}$  and 2 s later, another ball  $B$  is projected vertically down with the same speed. Then

- a) Both  $A$  and  $B$  will reach the ground simultaneously
- b) The ball  $A$  will hit the ground 2 s later than  $B$  hitting the ground
- c) Both the balls will hit the ground with the same velocity
- d) Both will rebound to the same height from the ground, if both have same coefficient of restitution

219. A ball is dropped from a height of 49 m, the wind blows horizontally and imparts a constant acceleration of  $4.90 \text{ ms}^{-2}$  to the ball. Choose the correct statement(s)

- a) Path of the ball is a straight line
- b) Path of the ball is a curved one
- c) The time taken by the ball to reach the ground is 3.16 s
- d) The angle made by the line joining initial and final positions (on ground after 1<sup>st</sup> strike) of the ball with horizontal is greater than  $45^\circ$

220. A particle is projected at an angle  $\theta = 30^\circ$  with the horizontal, with a velocity of  $10 \text{ ms}^{-1}$ . Then

- a) After 2 s the velocity of particle makes an angle of  $60^\circ$  with initial velocity vector
- b) After 1 s the velocity of particle makes an angle of  $60^\circ$  with initial velocity vector
- c) The magnitude of velocity of particle after 1 s is  $10 \text{ ms}^{-1}$
- d) The magnitude of velocity of particle after 1 s is  $5 \text{ ms}^{-1}$

221. For a particle moving along the  $x$ -axis,  $x - t$  graph is as given in Fig. Mark the correct statement(s)

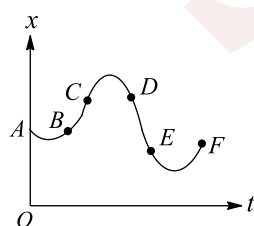

- a) Initial velocity of the particle is zero
- b) For  $BC$ , acceleration is positive and for  $DE$ , acceleration is negative
- c) For  $EF$ , the acceleration is positive



- d) Velocity becomes zero three times in the motion
222. A particle is projected from a point  $A$  with a velocity  $v$  at an angle of elevation  $\theta$ . At a certain point  $B$ , the particle moves at right angle to its initial direction. Then
- a) Velocity of particle at  $B$  is  $v \sin \theta$                       b) Velocity of particle at  $B$  is  $v \cot \theta$   
 c) Velocity of particle at  $B$  is  $v \tan \theta$                       d) Velocity of flight from  $A$  to  $B$  is  $\frac{v}{g \sin \theta}$
223. An object is projected at an angle of  $45^\circ$  with the horizontal. The horizontal range and maximum height reached will be in the ratio
- a) 1 : 2                      b) 2 : 1                      c) 4 : 1                      d) 3 : 2
224. A body of mass  $m$  is moving in a circle of radius  $r$  with a constant speed  $v$ . The force on the body is  $mv^2/r$  and is directed towards the centre. What is the work done by this force in moving the body over half the circumference of the circle
- a)  $\frac{mv^2}{r} \times \pi r$                       b)  $\frac{mv^2}{r^2}$                       c) Zero                      d)  $\frac{\pi r}{mv^2}$
225. A body is projected with velocity  $u$  at an angle of projection  $\theta$  with the horizontal. The direction of velocity of the body makes angle  $30^\circ$  with the horizontal at  $t = 2$  s and then after 1 s it reaches the maximum height. Then
- a)  $u = 20\sqrt{3}\text{ms}^{-1}$                       b)  $\theta = 60^\circ$                       c)  $\theta = 30^\circ$                       d)  $u = 10\sqrt{3}\text{ms}^{-1}$
226. A boat which has a speed of  $5 \text{ kmh}^{-1}$  in still water crosses a river of width 1 km along the shortest possible path in 15 min. The velocity of the river water in  $\text{kmh}^{-1}$  is
- a) 1                      b) 3                      c) 4                      d)  $\sqrt{41}$
227. Two particles  $A$  and  $B$  start simultaneously from the same point and move in the horizontal plane.  $A$  has an initial velocity  $u_1$  due east and acceleration  $a_1$  due north.  $B$  has an initial velocity  $u_2$  due north and acceleration  $a_2$  due east
- a) They must collide at some point  
 b) They will collide only if  $a_1 u_1 = a_2 u_2$   
 c) Their paths must intersect at some point  
 d) If  $u_1 > u_2$  and  $a_1 < a_2$ , the particles will have the same speed at some point
228. The speed of revolution of a particle moving round a circle is doubled and its angular speed is halved. What happens to the centripetal acceleration?
- a) Unchanged                      b) Halved                      c) Doubled                      d) 4 times
229. Two cities  $A$  and  $B$  are connected by a regular bus services with buses plying in either direction every  $T$  seconds. The speed of each bus is uniform and equal to  $V_b$ . A cyclist cycles from  $A$  to  $B$  with a uniform speed of  $V_c$ . A bus goes past the cyclist in  $T_1$  second in the direction  $A$  to  $B$  and every  $T_2$  second in the direction  $B$  to  $A$ . Then
- a)  $T_1 = \frac{V_b T}{V_b + V_c}$                       b)  $T_2 = \frac{V_b T}{V_b - V_c}$                       c)  $T_1 = \frac{V_b T}{V_b - V_c}$                       d)  $T_2 = \frac{V_b T}{V_b + V_c}$
230. A river is flowing from west to east at a speed of 5 m per min. A man on the south bank of the river, capable of swimming at 10 m per min in still water, wants to swim across the river in the shortest time. He should swim in a direction
- a) Due north                      b)  $30^\circ$  east of north                      c)  $30^\circ$  west of north                      d)  $60^\circ$  east of north
231. For a particle moving along the  $x$ -axis, a scaled  $x - t$  graph is shown in Fig. Mark the correct statement(s)



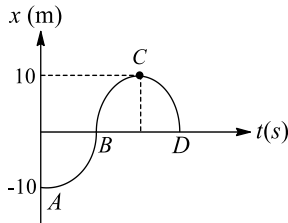

- a) Speed of the particle is greatest at C  
 b) Speed of the particle is greatest at B  
 c) Particle is speeding up in region marked CD  
 d) Particle is speeding up in the region marked AB
232. A particle moves along positive branch of the curve,  $y = \frac{x}{2}$ , where  $x = \frac{t^3}{3}$ ,  $x$  and  $y$  are measured in metres and  $t$  in seconds, then
- a) The velocity of particle at  $t = 1$  s is  $\hat{i} + \frac{1}{2}\hat{j}$   
 b) The velocity of particle at  $t = 1$  s is  $\frac{1}{2}\hat{i} + \hat{j}$   
 c) The acceleration of particle at  $t = 2$  s is  $2\hat{i} + \hat{j}$   
 d) The acceleration of particle at  $t = 2$  s is  $\hat{i} + 2\hat{j}$
233. A particle is thrown in vertically in upward direction and passes three equally speed windows of equal heights then

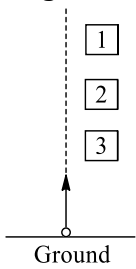

- a) The average speed of the particle while passing the windows satisfy the relation  $v_{av_1} > v_{av_2} > v_{av_3}$   
 b) The time taken by the particle to cross the windows satisfies the relation  $t_1 < t_2 < t_3$   
 c) The magnitude of the acceleration of the particle while crossing the windows, satisfies the relation  $a_1 = a_2 \neq a_3$   
 d) The change in the speed of the particle, while crossing the windows, would satisfy the relation  $\Delta v_1 < \Delta v_2 < \Delta v_3$
234. For a particle of a rotating rigid body  $v = r\omega$ , so
- a)  $\omega \propto (1/r)$       b)  $\omega \propto v$       c)  $v \propto r$       d)  $\omega$  is independent of  $r$
235. A ball is dropped vertically from a height  $d$  above the ground. It hits the ground and bounces up vertically to a height  $d/2$ . Neglecting subsequent motion and air resistance, its velocity  $v$  varies with the height  $h$  above the ground as

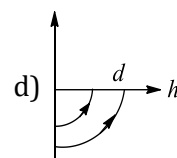
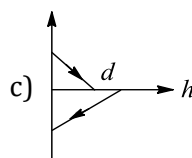
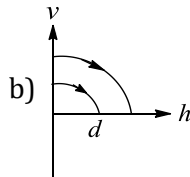
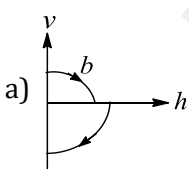

236. A particle is moving along the  $x$ -axis whose position is given by  $x = 4 - 9t + \frac{t^3}{3}$ . Mark the correct statement (s) in relation to its motion
- a) The direction of motion is not changing at any of the instants  
 b) The direction of motion is changing at  $t = 3$  s



- c) For  $0 < t < 3$  s, the particle is slowing down  
d) For  $0 < t < 3$  s, the particle is speeding up
237. For a particle moving along the  $x$ -axis, mark the correct statement (s)
- a) If  $x$  is positive and is increasing with the time, then average velocity of the particle is positive  
b) If  $x$  is negative and becoming positive after some time, then the velocity of the particle is always positive  
c) If  $x$  is negative and becoming less negative as time passes, then the average velocity of the particle is positive  
d) If  $x$  is positive and is increasing with time, then the velocity of the particle is always positive

### Assertion - Reasoning Type

This section contain(s) 0 questions numbered 238 to 237. Each question contains STATEMENT 1 (Assertion) and STATEMENT 2 (Reason). Each question has the 4 choices (a), (b), (c) and (d) out of which **ONLY ONE** is correct.

- a) Statement 1 is True, Statement 2 is True; Statement 2 is correct explanation for Statement 1  
b) Statement 1 is True, Statement 2 is True; Statement 2 is **not** correct explanation for Statement 1  
c) Statement 1 is True, Statement 2 is False  
d) Statement 1 is False, Statement 2 is True
- 238
- Statement 1:** A river is flowing from east to west at a speed of 5 m/min. A man on the south bank of river, capable of swimming 10 m/min in still water, wants to swim across the river in shortest time. He should swim due north  
**Statement 2:** For the shortest time the man needs to swim perpendicular to the bank
- 239
- Statement 1:** During a turn, the value of centripetal force should be less than the limiting frictionless force  
**Statement 2:** The centripetal force is provided by the frictional force between the tyres and the road
- 240
- Statement 1:** The projectile has only vertical component of velocity at the highest point of its trajectory  
**Statement 2:** At the highest point only one component of velocity is present
- 241
- Statement 1:** angle between  $\hat{i} + \hat{j}$  and  $\hat{i}$  is  $45^\circ$   
**Statement 2:**  $\hat{i} + \hat{j}$  is equally include to both  $\hat{i}$  and  $\hat{j}$  and the angel between  $\hat{i}$  and  $\hat{j}$  is  $90^\circ$
- 242
- Statement 1:** An iron ball and a wooden ball are both released from the same height. In the presence of a medium both the balls reach the ground with different velocities and different times



**Statement 2:** Both the balls reach the ground simultaneously

243

**Statement 1:** Improper banking of roads causes wear and tear of tyres

**Statement 2:** The necessary centripetal force in that event is provided by the force of friction between the tyres and the road

244

**Statement 1:** For uniformly accelerated motion started from rest, the displacement versus time graph is a straight line

**Statement 2:** For uniformly accelerated motion, the velocity in equal intervals of time changes by same amount

245

**Statement 1:** At the highest point of projectile motion given angular projection, the velocity is not zero

**Statement 2:** Only the vertical component of velocity is zero whereas horizontal component still exists

246

**Statement 1:** Improper banking of roads causes wear and tear of tyres

**Statement 2:** The necessary centripetal force is provided by the force of friction between the tyres and the road

247

**Statement 1:** The pendulum of a clock is made of alloys and not a pure metals

**Statement 2:** Use of alloys makes the pendulum look good

248

**Statement 1:** A body with constant acceleration always moves along a straight line

**Statement 2:** A body with constant magnitude of acceleration may not speed up

249

**Statement 1:** The direction of velocity vector is always along the tangent to the path; therefore, its magnitude may be given by its slope

**Statement 2:** The slope of tangent to path only measures the direction of velocity at that point

250

**Statement 1:** If both the speed of a body and radius of its circular path are doubled, then centripetal force also gets doubled

**Statement 2:** Centripetal force is directly proportional to both speed of a body and radius of circular path

251



**Statement 1:** When a particle moves on a circular path with constant speed, it is called uniform circular motion.

**Statement 2:** For a uniform circular motion, necessary a force is always acting parallel to the direction of velocity

252

**Statement 1:** A physical quantity cannot be called as a vector if its magnitude is zero.

**Statement 2:** A vector has both, magnitude and direction.

253

**Statement 1:** Angular velocity of seconds hand of a watch is  $\frac{\pi}{30} \text{ rad s}^{-1}$

**Statement 2:**  $\omega = \frac{2\pi}{T} = \frac{2\pi}{60} = \frac{\pi}{30} \text{ rad s}^{-1}$

254

**Statement 1:** The resultant of three vectors  $\vec{OA}$  and  $\vec{OB}$  and  $\vec{OC}$  as shown in figure is  $R(1 + \sqrt{2})$ .  $R$  is the radius of circle

**Statement 2:**  $\vec{OA} + \vec{OC}$  is along  $\vec{OB}$  and  $(\vec{OA} + \vec{OC}) + \vec{OB}$  is along  $\vec{OB}$ .

255

**Statement 1:** The maximum horizontal range of projectile is proportional to square of velocity

**Statement 2:** The maximum horizontal range of projectile is equal to maximum height attained by projectile

256

**Statement 1:** In a non-uniform circular motion, tangential acceleration arises due to change in magnitude of velocity

**Statement 2:** In a non-uniform circular motion, centripetal acceleration is produced due to change in direction of velocity

257

**Statement 1:** Least count of all screw-based instruments is same

**Statement 2:** Least count for all screw-based instruments is found using the ratio pitch per division of circular scale

258

**Statement 1:** When an automobile is going too fast around curve overturns, its inner wheels leave the ground first

**Statement 2:** For a safe turn the velocity of automobile should be less than the value of safe limiting velocity

259

**Statement 1:** Speed and velocity are different physical quantities

**Statement 2:** Both speed and velocity have same unit ( $\text{ms}^{-1}$ )



260

**Statement 1:** The vector  $\frac{1}{\sqrt{3}}\hat{i} + \frac{1}{\sqrt{3}}\hat{j} + \frac{1}{\sqrt{3}}\hat{k}$  is a unit vector.

**Statement 2:** Unit vector is one which has unit magnitude and a given direction.

261

**Statement 1:** The  $v - t$  graph perpendicular to the time axis is not possible in practice

**Statement 2:** Infinite acceleration can't be realised in practice

262

**Statement 1:** If the string of an oscillating simple pendulum is cut, when the bob is at the mean position, the bob falls along a parabolic path

**Statement 2:** The bob possesses horizontal velocity at the mean position

263

**Statement 1:** A coin is placed on phonogram turn table. The motor is started, coin moves along the moving table

**Statement 2:** The rotating table is providing necessary centripetal force to the coin

264

**Statement 1:** A vector  $\vec{A}$  points vertically upwards and  $\vec{B}$  points towards North. The vector product  $\vec{A} \times \vec{B}$  is along East.

**Statement 2:** The direction of  $\vec{A} \times \vec{B}$  is given by right hand rule.

265

**Statement 1:** Backlash error can be minimized by turning the screw in one direction only when fine adjustment is done

**Statement 2:** Backlash error is because due to wear and tear or loose fittings of screws

266

**Statement 1:** As the frictional force increases, the safe velocity limit for taking a turn on an unbanked road also increases

**Statement 2:** Banking of roads will increase the value of limiting velocity

267

**Statement 1:** In projectile motion, the angle between the instantaneous velocity and acceleration at the highest point is  $180^\circ$

**Statement 2:** At the highest point, velocity of projectile will be in horizontal direction only

268

**Statement 1:** In circular motion, the centripetal and centrifugal force acting in opposite direction balance each other



**Statement 2:** Centripetal and centrifugal forces don't act at the same time

269

**Statement 1:** The trajectory of projectile is quadratic in  $y$  and linear in  $x$

**Statement 2:**  $y$  component of trajectory is independent of  $x$ -component

270

**Statement 1:**  $\vec{v} = \vec{\omega} \times \vec{r}$  and  $\vec{v} \neq \vec{r} \times \vec{\omega}$

**Statement 2:** Cross product of vector is commutative

271

**Statement 1:** In a plane projectile motion, the angle between instantaneous velocity vector and acceleration vector can be anything between  $0$  or  $\pi$  (excluding the limiting case)

**Statement 2:** In plane to plane projectile motion, acceleration vector is always pointing vertical downwards. (neglect air friction)

272

**Statement 1:** When a vehicle takes a turn on the road, it travels along a nearly circular path

**Statement 2:** In circular motion, velocity of vehicle remains same

273

**Statement 1:** When the velocity of projection of a body is made  $n$  time, its time of flight becomes  $n$  times

**Statement 2:** Range of projectile does not depend on the initial velocity of body

274

**Statement 1:** Two particles start from rest simultaneously and proceed with the same acceleration. The relative velocity of these particles will be zero throughout the motion

**Statement 2:** At every moment the two particles will have the same velocity

275

**Statement 1:** A safe turn by a cyclist should neither be fast nor sharp

**Statement 2:** The bending angle from the vertical would decrease with increase in velocity

276

**Statement 1:** In order to hit a target, a man should point his rifle in the same direction as target

**Statement 2:** The horizontal range of the bullet is dependent on the angle of projectile with horizontal direction

277



- 278
- Statement 1:** Two similar trains are moving along the equatorial line with the same speed but in opposite direction. They will exert equal pressure on the rails
- Statement 2:** In uniform circular motion the magnitude of acceleration remains constant but the direction continuously changes
- 279
- Statement 1:** When an automobile while going too fast around a curve overturns, its inner wheels leave the ground first
- Statement 2:** For a safe turn the velocity of automobiles should be less than the value of safe limit velocity
- 280
- Statement 1:** In a uniform circular motion, the angle between velocity vector and acceleration vector is always  $\pi/2$
- Statement 2:** For any type of motion, the angle between acceleration and velocity is always  $\pi/2$
- 281
- Statement 1:** Two particles of different mass, projected with same velocity at same angles. The maximum height attained by both the particle will be same
- Statement 2:** The maximum height of projectile is independent of particle mass
- 282
- Statement 1:** Plotting the acceleration-time graph from a given position-time graph of a particle moving along a straight line is possible
- Statement 2:** From position-time graph, only the sign of acceleration can be determined but no information can be concluded about the magnitude of acceleration
- 283
- Statement 1:** For looping a vertical loop of radius  $r$ , the minimum velocity at the lowest point should be  $\sqrt{5gr}$
- Statement 2:** In that event, velocity at the highest point would be zero
- 284
- Statement 1:** The path of a projectile is parabolic only when the acceleration of the projectile is constant
- Statement 2:** Acceleration of projectile is constant, if projectile does not go to very large height, in gravitational field
- 285
- Statement 1:** In case of angular projection of a projectile the maximum height occurs when the projectile covers a horizontal distance equal to half of the horizontal range



**Statement 2:** Maximum height occurs when angle of projection is  $90^\circ$

286

**Statement 1:** Screw gauge with a pitch of 0.5 mm is more accurate than 1 mm for same number of circular scale divisions

**Statement 2:** Higher pitch can make an accurate device

287

**Statement 1:** When a body is dropped or thrown horizontally from the same height, it would reach the ground at the same time

**Statement 2:** Horizontal velocity has no effect on the vertical direction

288

**Statement 1:** The time of flight of a body becomes  $n$  times the original value if its speed is made  $n$  times

**Statement 2:** This due to the range of the projectile which becomes  $n$  times

289

**Statement 1:** A safe turn by a cyclist should neither be fast nor sharp

**Statement 2:** As the bending of angle from the vertical would decrease

290

**Statement 1:** A football whether kicked at  $30^\circ$  or  $60^\circ$  will strike the ground at the same place, although when kicked at  $60^\circ$ , it will remain longer in the air

**Statement 2:** Air resistance is more for larger angle

291

**Statement 1:** When range of a projectile is maximum, its angle of projection may be  $45^\circ$  or  $135^\circ$

**Statement 2:** Whether  $\theta$  is  $45^\circ$  or  $135^\circ$ , value of range remains the same, only the sign changes

292

**Statement 1:** Two bombs of 5kg and 10kg are thrown from a cannon in the same direction with different velocities, then both will reach the earth simultaneously

**Statement 2:** Time of flight does not depend upon mass

293

**Statement 1:** A body of mass 1 kg is making 1 rps in a circle of radius 1 m. centrifugal force acting on it is  $4\pi^2 N$

**Statement 2:** Centrifugal force is given by  $F = \frac{mv^2}{r}$



**Matrix-Match Type**

This section contain(s) 0 question(s). Each question contains Statements given in 2 columns which have to be matched. Statements (A, B, C, D) in **columns I** have to be matched with Statements (p, q, r, s) in **columns II**.

294. A ball is projected from the ground with velocity  $v$  such that its range is maximum

Column-I	Column- II
(A) Velocity at half of the maximum height	(p) $\frac{\sqrt{3}v}{2}$
(B) Velocity at the maximum height	(q) $\frac{v}{\sqrt{2}}$
(C) Change in its velocity when it returns to the ground	(r) $v\sqrt{2}$
(D) Average velocity when it reaches the maximum height	(s) $\frac{v}{2}\sqrt{\frac{5}{2}}$

**CODES :**

	A	B	C	D
a)	b	c	d	a
b)	c	b	a	d
c)	a	b	c	d
d)	d	a	b	c

295. The path of projectile is represented by  $y = Px - Qx^2$

Column-I	Column- II
(A) Range	(p) $P/Q$
(B) Maximum height	(q) $P$
(C) Time of flight	(r) $P^2/4Q$
(D) Tangent of angle of projection is	(s) $\sqrt{\frac{2}{Qg}}P$

**CODES :**

	A	B	C	D
a)	c	d	a	b
b)	a	c	b	d
c)	b	d	c	a



d) a c d b

296. The trajectories of the motion of three particles are shown in Fig. Match the entries of Column I with the entries of Column II

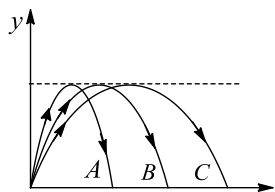

Column-I

Column- II

- |   |                                |
|---|--------------------------------|
| (A) Time of flight is least for   | (p) A                          |
| (B) Velocity is greatest for Horizontal component of the velocity is greatest for | (q) B                          |
| (C) Horizontal component of the velocity is greatest for                          | (r) C                          |
| (D) Launch speed is least for   | (s) No appropriate match given |

CODES :

	A	B	C	D
a)	d	d	c	a
b)	d	c	a	b
c)	a	c	d	b
d)	b	a	c	a

297. A body is projected with a velocity of  $60 \text{ ms}^{-1}$  at  $30^\circ$  to horizontal

Column-I

Column- II

- |                             |                                     |
|-----------------------------|-------------------------------------|
| (A) Initial velocity vector | (p) $60\sqrt{3}\hat{i} + 40\hat{j}$ |
| (B) Velocity after 3 s      | (q) $30\sqrt{3}\hat{i} + 10\hat{j}$ |
| (C) Displacement after 2 s  | (r) $30\sqrt{3}\hat{i} + 30\hat{j}$ |
| (D) Velocity after 2 s      | (s) $30\sqrt{3}\hat{i}$             |

CODES :

	A	B	C	D
a)	d	c	b	a
b)	c	d	a	b
c)	a	b	d	c



d) b a c d

298. Study the following  $v - t$  graphs in Column I carefully and match appropriately with the statements given in Column II. Assume that motion takes place from time 0 to  $T$

Column-I

Column- II

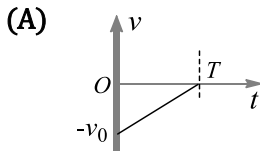

(p) Net displacement is positive, but not zero

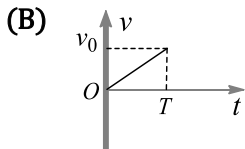

(q) Net displacement is negative, but not zero

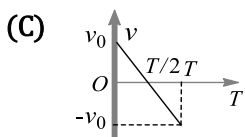

(r) Particle returns to its initial position again

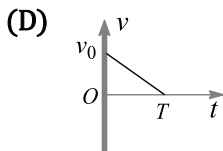

(s) Acceleration is positive

CODES :

	A	B	C	D
a)	B,d	a,d	c	a
b)	a	c	a,d	b,d
c)	a,d	c	a	c
d)	d	a	a,d	a,c

299. Match the entries of Column I with that of Column II

Column-I

Column- II

(A) For a particle moving in a circle

(p) The acceleration may be perpendicular to its velocity

(B) For a particle moving in a straight line velocity

(q) The acceleration may be in the direction of

(C) For a particle undergoing projectile motion with angle of projection  $\alpha$ ;  $0 \leq \alpha \leq \frac{\pi}{2}$

(r) The acceleration may be at some angle  $\theta$  ( $0 < \theta < \frac{\pi}{2}$ ) with the velocity

(D) For a particle is moving in space

(s) The acceleration may be opposite to its velocity

CODES :

A	B	C	D
---	---	---	---



- a) B,d a,c c a,b  
 b) a,c b,d a,c a,b,c,d  
 c) a,b,c,d a,c b,d a,d  
 d) b,c a,d a,c b,d

300. The velocity time graph of a particle moving along the  $x$ -axis is shown in Fig. Match the entries of Column I with entries of Column II

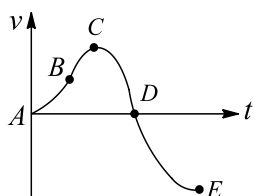

Column-I

Column- II

- |                                |   |
|--------------------------------|---|
| (A) For $AB$ , the particle is | (p) Moving in positive $x$ -direction with increasing speed |
| (B) For $BC$ , the particle is | (q) Moving in positive $x$ -direction with decreasing speed |
| (C) For $CD$ , the particle is | (r) Moving in negative $x$ -direction with increasing speed |
| (D) For $DE$ , the particle is | (s) Moving in negative $x$ -direction with decreasing speed |

CODES :

	A	B	C	D
a)	a	a	b	c
b)	b	a	c	d
c)	c	d	b	a
d)	a	c	d	b

301. For a particle moving along the  $x$ -axis, if acceleration (constant) is acting along negative  $x$ -axis, then match the entries of Column I with entries of Column II

Column-I

Column- II

- |                            |  |
|----------------------------|--|
| (A) Initial velocity $> 0$ | (p) Particle may move in positive $x$ -direction with increasing speed |
| (B) Initial velocity $< 0$ | (q) Particle may move in positive $x$ -direction with decreasing speed |
| (C) $x > 0$                | (r) Particle may move in negative $x$ -direction with increasing speed |
| (D) $x < 0$                | (s) Particle may move in negative $x$ -direction with decreasing speed |



CODES :

	A	B	C	D
a)	a	b	c	a,c
b)	b	c	b,c	b,c
c)	b,c	b	c	a,d
d)	c	d	b,c	a

302. Figure shows the position-time graph of particle moving along a straight line. Match the entries of Column I with the entries of Column II

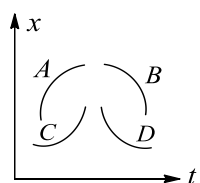

Column-I

Column- II

- |                       |                  |
|-----------------------|------------------|
| (A) The particle A is | (p) Accelerating |
| (B) The particle B is | (q) Decelerating |
| (C) The particle C is | (r) Speeding up  |
| (D) The particle D is | (s) Slowing down |

CODES :

	A	B	C	D
a)	A,c	b,d	a,d	a,c
b)	a	d	c	b
c)	b,d	a,c	a,c	b,d
d)	a,d	b,d	c	b

303. If  $\vec{v}_{mw}$  = velocity of a man relative to water,  $\vec{v}_w$  = velocity of water,  $\vec{v}_m$  = velocity of man relative to ground, match the following

Where  $\theta$  = angle between  $\vec{v}_{mw}$  and the width of the river

Column-I

Column- II

- |   |  |
|---|--|
| (A) Minimum distance for $v_{mw} > v_w$ | (p) $\theta = \sin^{-1} \left( \frac{v_{mw}}{v_w} \right)$ |
| (B) Minimum time for $v_{mw} \geq v_w$  | (q) $\vec{v}_m \perp \vec{v}_w$                            |
| (C) Minimum distance for $v_{mw} < v_w$ | (r) $\vec{v}_{mw} \perp \vec{v}_w$                         |



(D) Minimum time for  $v_{m\omega} > v_w$

$$(s) \quad \theta = \sin^{-1} \frac{v_w}{v_{mw}}$$

CODES :

	A	B	C	D
a)	B,d	c	a	c
b)	c	a	b	d
c)	b	d	a	c
d)	a	b,d	c	a

### Linked Comprehension Type

This section contain(s) 41 paragraph(s) and based upon each paragraph, multiple choice questions have to be answered. Each question has atleast 4 choices (a), (b), (c) and (d) out of which **ONLY ONE** is correct.

#### Paragraph for Question Nos. 304 to -304

When a stone tied to one end of a string is rotated in a vertical circle, its velocity goes on changing on account of gravity. For looping the loop, velocity at lowest point is  $v_L = \sqrt{5gr}$ ; tension in the string,  $T_L \geq 6mg$ . The string does not slacken at the highest point when  $v_H \geq \sqrt{gr}$  and  $T_H \geq 0$ . The stone leaves the vertical circle when tension in the string vanishes before its velocity becomes zero. For this,  $\sqrt{2gr} < v_L < \sqrt{5gr}$ . Read the above passage and answer the following questions when mass of stone is 100 g, length of string is 1 m and  $g = 9.8 \text{ ms}^{-2}$

304. If  $v_L = 7 \text{ ms}^{-1}$ , velocity at highest point will be

- a)  $1 \text{ ms}^{-1}$                       b) Zero                      c)  $3.13 \text{ ms}^{-1}$                       d) Cannot say

#### Paragraph for Question Nos. 305 to -305

When a vehicle rounds a curve, it requires some centripetal force  $= mv^2/r$ . If the road is unbanked, the necessary force is provided by the force of friction between the tyres and road. To avoid skidding, the speed of vehicle must be  $\leq \sqrt{\mu rg}$ , and to avoid overturning, the speed must be  $\leq \sqrt{\frac{grx}{h}}$ , where  $2x$  is the wheel base and  $h$  is height of centre of gravity, above the road. The dependence on friction can be avoided if the road is suitably banked. The safe speed then rises to  $\sqrt{rg \tan \theta}$ . In no case, the speed limits depend upon mass of the vehicle. Read the above passage and answer the following questions, when mass of car is 800 kg, wheel base is 1.1 m, height of centre of gravity is 50 cm, banking angle is  $30^\circ$  and radius of curve is 200 m (Take  $g = 9.8 \text{ ms}^{-2}$ , and  $\mu = 0.2$ )

305. The safe speed to avoid skidding on the unbanked curve is

- a)  $9.8 \text{ ms}^{-1}$                       b)  $19.8 \text{ ms}^{-1}$                       c)  $10 \text{ ms}^{-1}$                       d)  $1.98 \text{ ms}^{-1}$



**Paragraph for Question Nos. 306 to - 306**

A motor cyclist is riding North in still air at  $36 \text{ kmh}^{-1}$ . The wind starts blowing West ward with a velocity  $18 \text{ kmh}^{-1}$ .

306. The direction of apparent velocity is

- a)  $\tan^{-1}(1/2)$  West of North  
b)  $\tan^{-1}(1/2)$  North of West  
c)  $\tan^{-1}(1/2)$  East of North  
d)  $\tan^{-1}(1/2)$  North of East

**Paragraph for Question Nos. 307 to - 307**

A projectile is thrown from the ground with a speed of  $2\sqrt{gh}$  at an angle of  $60^\circ$  to the horizontal from a point on the horizontal ground

307. The horizontal range of projectile is

- a)  $\sqrt{3}h$   
b)  $2\sqrt{3}h$   
c)  $\sqrt{3}h/2$   
d)  $3h/2$

**Paragraph for Question Nos. 308 to - 308**

Two second after projection, a projectile is travelling in a direction inclined at  $30^\circ$  to the horizontal. After 1 more second, it is travelling horizontally (Use  $g = 10 \text{ ms}^{-2}$ )

308. The initial velocity of its projection is

- a)  $10 \text{ ms}^{-1}$   
b)  $10\sqrt{3} \text{ ms}^{-1}$   
c)  $20 \text{ ms}^{-1}$   
d)  $20\sqrt{3} \text{ ms}^{-1}$

**Paragraph for Question Nos. 309 to - 309**

A man is walking due east at the speed of  $3 \text{ kmh}^{-1}$ . Rain appears to fall down vertically at the rate of  $3 \text{ kmh}^{-1}$

309. The actual velocity of the rainfall is

- a)  $3\sqrt{3} \text{ kmh}^{-1}$   
b)  $2\sqrt{2} \text{ kmh}^{-1}$   
c)  $4\sqrt{3} \text{ kmh}^{-1}$   
d)  $3\sqrt{2} \text{ kmh}^{-1}$

**Paragraph for Question Nos. 310 to - 310**

A car is moving towards south with a speed of  $20 \text{ ms}^{-1}$ . A motorcyclist is moving towards east with a speed of  $15 \text{ ms}^{-1}$ . At a certain instant, the motorcyclist is due south of the car and is at a distance of 50 m from the car

310. The shortest distance between the motorcyclist and the car is

- a) 10 m  
b) 20 m  
c) 30 m  
d) 40 m



**Paragraph for Question Nos. 311 to - 311**

A man can swim at a speed of  $3 \text{ kmh}^{-1}$  in still water. He wants to cross a  $500 \text{ m}$  wide river flowing at  $2 \text{ kmh}^{-1}$ . He keeps himself always at an angle to  $120^\circ$  with the river flow while swimming

311. The time taken to cross the river is

- a)  $\frac{3}{2}h$                       b)  $\frac{1}{6}h$                       c)  $\frac{1}{3\sqrt{3}}h$                       d) None

**Paragraph for Question Nos. 312 to - 312**

To a stationary man, rain appears to be falling at his back at an angle  $30^\circ$  with the vertical. As he starts moving forward with a speed of  $0.5 \text{ ms}^{-1}$ , he finds that the rain is falling vertically

312. The speed of rain with respect to the stationary man is

- a)  $0.5$                       b)  $1.0 \text{ ms}^{-1}$                       c)  $0.5 \sqrt{3} \text{ ms}^{-1}$                       d)  $0.43 \text{ ms}^{-1}$

**Paragraph for Question Nos. 313 to - 313**

From a tower of height  $40 \text{ m}$ , two bodies are simultaneously projected horizontally in opposite directions, with velocities  $2 \text{ ms}^{-1}$  and  $8 \text{ ms}^{-1}$  respectively

313. The time taken for the velocity vectors of two bodies to become perpendicular to each other is

- a)  $0.1 \text{ s}$                       b)  $0.2 \text{ s}$                       c)  $0.4 \text{ s}$                       d)  $0.8 \text{ s}$

**Paragraph for Question Nos. 314 to - 314**

A particle starts from origin at  $t = 0$  with a velocity  $5.0 \hat{i} \text{ ms}^{-1}$  and moves in the  $x - y$  plane under the action of a force which produces a constant acceleration of  $3.0 \hat{i} + 2.0 \hat{j} \text{ ms}^{-2}$ ,

314. The  $y$ -coordinate of the particle at the instant its  $x$ -coordinate is  $84 \text{ m}$ :

- a)  $84 \text{ m}$                       b)  $56 \text{ m}$                       c)  $48 \text{ m}$                       d)  $36 \text{ m}$

**Paragraph for Question Nos. 315 to - 315**

A ball is thrown from a point in level with velocity  $u$  and at a horizontal distance  $r$  from the top of a tower of height  $h$

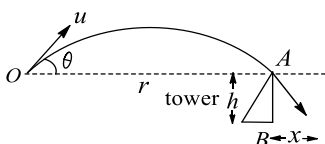

315. How must the speed and angle of the projection of the ball be related to  $r$  in order that the ball may just go grazing the top edge of the tower?

- a)  $gr = u^2 \sin 2\theta$       b)  $gr = u^2 \sin \theta$       c)  $gr = u^2 \cos 2\theta$       d)  $gr = u^2 \cos \theta$

**Paragraph for Question Nos. 316 to - 316**

A 0.098 kg block slides down a frictionless track as shown in Fig

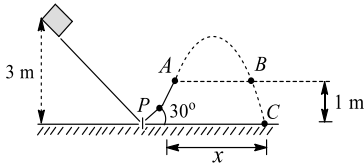

316. The vertical component of the velocity of block at A is

- a)  $\sqrt{g}$       b)  $2\sqrt{g}$       c)  $3\sqrt{g}$       d)  $4\sqrt{g}$

**Paragraph for Question Nos. 317 to - 317**

A projectile is thrown with velocity  $v$  making an angle  $\theta$  with the horizontal. It just crosses the tops of two poles, each of height  $h$ , after 1s and 3 s, respectively

317. The time of flight of the projectile is

- a) 1 s      b) 3 s      c) 4 s      d) 7.8 s

**Paragraph for Question Nos. 318 to - 318**

A projectile is thrown with velocity  $v$  at an angle  $\theta$  with the horizontal. When the projectile is at a height equal to half of the maximum height,

318. The vertical component of the velocity of projectile is

- a)  $3 v \sin \theta$       b)  $v \sin \theta$       c)  $\frac{v \sin \theta}{\sqrt{2}}$       d)  $\frac{v \sin \theta}{\sqrt{3}}$

**Paragraph for Question Nos. 319 to - 319**

A block slides off a horizontal table top 1 m high with a speed of  $3 \text{ ms}^{-1}$

319. Find the horizontal distance from the edge of the table at which of the block strikes the floor

- a)  $\frac{10}{\sqrt{3}} \text{ m}$       b)  $\frac{3}{\sqrt{10}} \text{ m}$       c)  $\frac{3}{\sqrt{5}} \text{ m}$       d)  $\frac{5}{\sqrt{3}} \text{ m}$



**Paragraph for Question Nos. 320 to - 320**

A projectile shot at an angle of  $45^\circ$  above the horizontal, strikes a building 30 m away at a point 15 m above the point of projection

320. Find the speed of projection

- a)  $8\sqrt{5} \text{ ms}^{-1}$       b)  $6\sqrt{10} \text{ ms}^{-1}$       c)  $5\sqrt{6} \text{ ms}^{-1}$       d)  $10\sqrt{6} \text{ ms}^{-1}$

**Paragraph for Question Nos. 321 to - 321**

A particle is projected horizontally with a speed  $v = 5 \text{ ms}^{-1}$  from the top of a plane inclined at an angle  $\theta = 37^\circ$  to the horizontal as shown in Fig

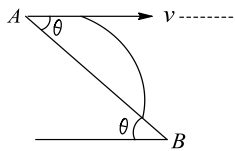

321. How far from the point of projection will the particle strike the plane?

- a) 75 m      b)  $\frac{65}{16} \text{ m}$       c)  $\frac{75}{16} \text{ m}$       d)  $\frac{85}{9} \text{ m}$

**Paragraph for Question Nos. 322 to - 322**

A particle is projected with a speed  $u$  at an angle  $\theta$  to the horizontal. Find the radius of curvature

322. At the highest point of its trajectory

- a)  $\frac{u^2 \cos^2 \theta}{2g}$       b)  $\frac{\sqrt{3}u^2 \cos^2 \theta}{2g}$       c)  $\frac{u^2 \cos^2 \theta}{g}$       d)  $\frac{\sqrt{3}u^2 \cos^2 \theta}{g}$

**Paragraph for Question Nos. 323 to - 323**

An inquisitive student, determined to test the law of gravity for himself, walks to the top of a building of 150 floors, with every floor of height 4 m, having a stopwatch in his hand (the 1<sup>st</sup> floor is at a height of 4 m from the ground level). From there he jumps off with negligible speed and hence starts rolling freely. A rocketeer arrives at the scene 5 s later and dives off from the top of the building to save the student. The racketeer leaves the roof with an initial downward speed  $v_0$ . In order to catch the student and to prevent injury to him, the racketeer should catch the student at a sufficiently great height above ground so that with zero velocity. The upward acceleration that accomplishes this is provided by rocketeer's jet pack, which he turns on just as he catches the student, before the racketeer is in free fall. To prevent any discomfort to the student, the magnitude of the acceleration of the racketeer and the student as they move downward together should not exceed  $5g$



323. Just as the student starts his free fall, he presses the button of the stopwatch. When he reaches at the top of 100<sup>th</sup> floor, he has observed the reading of stopwatch as 00:00: 0.6: 39 (hh: mm: ss: 100<sup>th</sup> part of the second). Find the value of  $g$ . (Correct up to two decimal places)

- a)  $9.80 \text{ ms}^{-2}$                       b)  $9.84 \text{ ms}^{-2}$                       c)  $9.75 \text{ ms}^{-2}$                       d)  $9.50 \text{ ms}^{-2}$

**Paragraph for Question Nos. 324 to - 324**

An elevator without a ceiling is ascending up with an acceleration of  $5 \text{ ms}^{-2}$ . A boy on the elevator shoots a ball in vertically upward direction from a height of 2 m above the floor of elevator. At this instant, the elevator is moving up with a velocity of  $10 \text{ ms}^{-1}$  and floor of the elevator is at a height of 50 m from the ground. The initial speed of the ball is  $15 \text{ ms}^{-1}$  w.r.t. the elevator. Consider the duration for which the ball strikes the floor of the elevator in answering following questions:

324. The time in which the ball strikes the floor of elevator is given by

- a) 2.13 s                                  b) 4.26 s                                  c) 1.0 s                                  d) 2.0 s

**Paragraph for Question Nos. 325 to - 325**

A particle traverses along a circular arc of radius 5 cm with constant of  $2.5 \text{ cms}^{-1}$  as shown in Fig

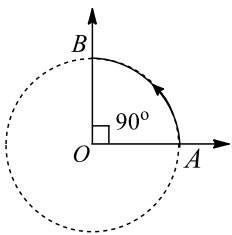

325. The average velocity over the interval AB is

- a)  $\frac{\sqrt{50}}{\pi} \text{ cms}^{-1}$                       b)  $\frac{\sqrt{10}}{\pi} \text{ cms}^{-1}$                       c)  $\sqrt{50}\pi \text{ cms}^{-1}$                       d)  $\sqrt{10}\pi \text{ cms}^{-1}$

**Paragraph for Question Nos. 326 to - 326**

Projectile motion is a combination of two one-dimensional motions: one in horizontal and other in vertical direction. Motion in 2 D means in a plane. Necessary condition for 2 D motion is that the velocity vector is coplanar to the acceleration vector. In case of projectile motion, the angle between velocity and acceleration will be  $0 < \theta < 180$ . During the projectile motion, the horizontal component of velocity remains unchanged but vertical component of velocity is time dependent. Now answer the following questions

326. A particle is projected from the origin in the  $x - y$  plane. The acceleration of particle in negative  $y$ -direction is  $a$ . If equation of path of the particle is  $y = ax = bx^2$ , then initial velocity of the particle is

- a)  $\sqrt{\frac{a}{2b}}$                                   b)  $\sqrt{\frac{a(1 + a^2)}{2b}}$                                   c)  $\sqrt{\frac{a}{a^2}}$                                   d)  $\sqrt{\frac{ab}{a^2}}$



**Paragraph for Question Nos. 327 to - 327**

A point moves in  $x - y$  plane according to the law  $x = a \sin \omega t$  and  $y = a - a \cos \omega t$ , where  $a$  is a positive constant and  $t$  is the time

327. The magnitude of velocity of the body at any instant of time  $t$  is  
 a)  $a\omega \cos \omega t$                       b)  $a\omega$                       c)  $a\omega \sin \omega t$                       d) None of these

**Paragraph for Question Nos. 328 to - 328**

A helicopter is flying at 200 m and flying at  $25 \text{ ms}^{-1}$  at an angle  $37^\circ$  above the horizontal when a package is dropped from it

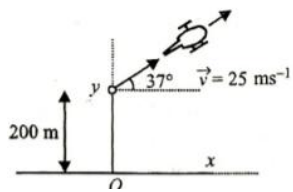

328. The distance of the point from point  $O$  where the package lands is  
 a) 80 m                      b) 100 m                      c) 200 m                      d) 160 m

**Paragraph for Question Nos. 329 to - 329**

$$\vec{a} = 4 \text{ ms}^{-2}\hat{i} + 3 \text{ ms}^{-2}\hat{j}$$

329. The velocity vector at  $t = 2 \text{ s}$  is  
 a)  $8\hat{i} - 3\hat{j}$                       b)  $6\hat{i} - 7\hat{j}$                       c)  $20\hat{i} - 5\hat{j}$                       d)  $10\hat{i} - 3\hat{j}$

**Paragraph for Question Nos. 330 to - 330**

Two particles are thrown simultaneously from points  $A$  and  $B$  with velocities  $u_1 = 2 \text{ ms}^{-1}$  and  $u_2 = 14 \text{ ms}^{-1}$ , respectively, as shown in Fig

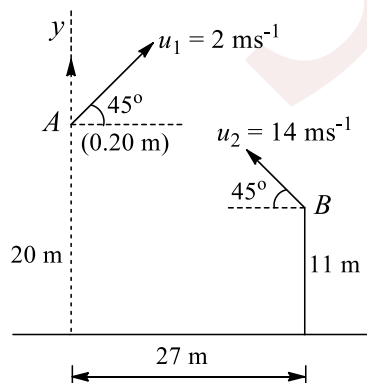

330. The relative velocity of  $B$  as seen from  $A$  in

- a)  $-8\sqrt{2}\hat{i} + 6\sqrt{2}\hat{j}$       b)  $4\sqrt{2}\hat{i} + 3\sqrt{3}\hat{j}$       c)  $3\sqrt{5}\hat{i} + 2\sqrt{3}\hat{j}$       d)  $3\sqrt{2}\hat{i} + 4\sqrt{3}\hat{j}$

**Paragraph for Question Nos. 331 to - 331**

Two inclined planes  $OA$  and  $OB$  having inclination (with horizontal)  $30^\circ$  and  $60^\circ$ , respectively, intersect each other at  $O$  as shown in Fig. A particle is projected from point  $P$  with velocity  $u = 10\sqrt{3}\text{ms}^{-1}$  along a direction perpendicular to plane  $OA$ . If the particle strikes plane  $OB$  perpendicular at  $Q$ , calculate

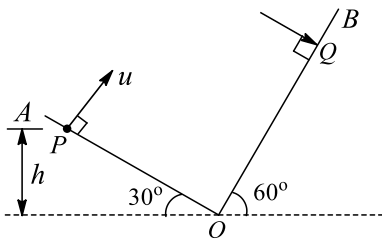

331. The velocity with which particle strikes the plane  $OB$

- a)  $15\text{ms}^{-1}$       b)  $30\text{ms}^{-1}$       c)  $20\text{ms}^{-1}$       d)  $10\text{ms}^{-1}$

**Paragraph for Question Nos. 332 to - 332**

The  $x - t$  graph of a particle moving along a straight line is shown in Fig

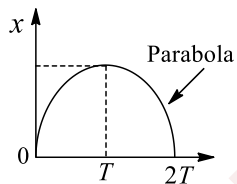

332. The  $v - t$  graph of the particle is correctly shown by

- a)      b)      c)      d)

**Paragraph for Question Nos. 333 to - 333**

We know that when a boat travels in water, its net velocity w.r.t. ground is the vector sum of two velocities. First is the velocity of boat itself in river and other is the velocity of water w.r.t. ground. Mathematically

$$\vec{v}_{\text{boat}} = \vec{v}_{\text{boat,water}} + \vec{v}_{\text{water}}$$

Now given that velocity of water w.r.t. ground in a river is  $u$ . Width of the river is  $d$



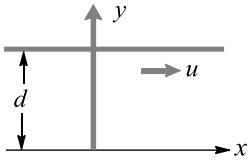

A boat starting from rest aims perpendicular to the river with an acceleration of  $a = 5t$ , where  $t$  is time. The boat starts from point  $(1, 0)$  of the coordinate system as shown in Fig. Assume SI units

333. Obtain the total time taken to cross the river

- a)  $(3d/5)^{1/3}$       b)  $(6d/5)^{1/3}$       c)  $(6d/5)^{1/2}$       d)  $(2d/3)^{1/3}$

### Integer Answer Type

334. A bead is free to slide down on a smooth wire rightly stretched between points  $A$  and  $B$  on a vertical circle of radius 10 m. Find the time taken by the bead to reach point  $B$ , if the bead slides from rest from the highest point on the circle  $A$

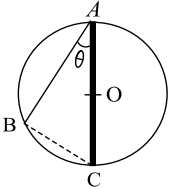

335. A golfer standing on level ground hits a ball with a velocity of  $52 \text{ ms}^{-1}$  at an angle  $\theta$  above the horizontal. If  $\tan \theta = \frac{5}{12}$ , then find the time for which the ball is atleast 15 m above the ground (taken  $g = 10 \text{ ms}^{-2}$ )

336. A particle is projected from the ground at an angle  $30^\circ$  with the horizontal with an initial speed  $20 \text{ ms}^{-1}$ . At what time after which velocity vector of projectile is perpendicular to the initial velocity? [in second]

337. Two particle  $P$  and  $Q$  move with constant velocities  $v_1 = 2 \text{ ms}^{-1}$  and  $v_2 = 4 \text{ ms}^{-1}$  along two mutually perpendicular straight lines towards the intersection point  $O$ . At moment  $t = 0$ , the particles were located at distances  $\ell_1 = 12 \text{ m}$  and  $\ell_2 = 19 \text{ m}$  from  $O$ , respectively. Find the time when they are nearest and also this shortest distance (nearest integer)

338. A particle is moving in a circular path of radius 1 m. Under the action of a centripetal force, the speed  $(\sqrt{2})\pi \text{ m/s}$  of the particle is constant. Find the average velocity (in m/s) between  $A$  and  $B$

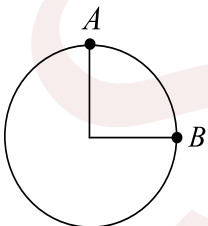

339. A particle is projected from a stationary trolley. After projection, the trolley moves with a velocity  $2\sqrt{15} \text{ m/s}$ . For an observer on the trolley, the direction of the particle is as shown in the figure while for the observer on the ground, the ball rises vertically. The maximum height reached by the ball from the trolley is  $h$  metre. The value of  $h$  will be



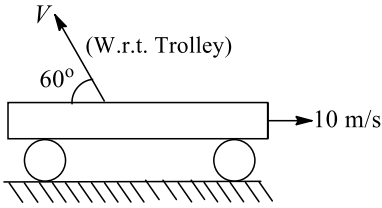

340. In a square cut, the speed of the cricket ball changes from 30 m/s to 40 m/s during the time of its contact  $\Delta t = 0.01$  s with the bat. If the ball is deflected by the bat through an angle of  $\theta = 90^\circ$ , find the magnitude of the average acceleration (in  $\times 10^2 \text{m/s}^2$ ) of the ball during the square cut
341. A staircase contains three steps each 10 cm high and 20 cm wide. What should be the minimum horizontal velocity of the ball rolling off the uppermost plane so as to hit directly the lowest plane? (in  $\text{ms}^{-1}$ )

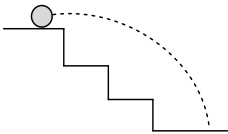

342. A train is moving along a straight line with a constant acceleration 'a'. A boy standing in the train throws a ball forward with a speed of 10 m/s, at an angle of  $60^\circ$  to the horizontal. The boy has to move forward by 1.15 m inside the train to catch the ball back at the initial height. The acceleration of the train, in  $\text{m/s}^2$ , is
343. A ball is projected from the origin. The  $x$ - and  $y$ -coordinates of its displacement are given by  $x = 3t$  and  $y = 4t - 5t^2$ . Find the velocity of projection (in m/sec)
344. A particle is moving in a circle of radius  $R$  with constant speed. The time period of the particle is  $T = 1$ . In a time  $t = T/6$ , if the difference between average speed and average velocity of the particle is  $2 \text{ms}^{-1}$ , find the radius  $R$  of the circle (in metres)
345. A projectile is launched at time  $t = 0$  from point  $A$  which is at height 1 m above the floor with speed  $v$  m/sec and at an angle  $\theta = 45^\circ$  with the floor. It passes through a hoop at  $B$  which is 1 m above  $A$  and  $B$  is the highest point of the trajectory. The horizontal distance between  $A$  and  $B$  is  $d$  metres. The projectile then falls into a basket, hitting the floor at  $C$  a horizontal distance  $3d$  metres from  $A$ . Find  $l$  (in m)

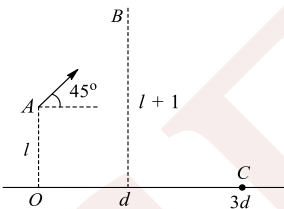

346. A particle moves rectilinearly possessing a parabolic  $s - t$  graph. Find the average velocity of the particle over a time interval from  $t = \frac{1}{2}$  s to  $t = 1.5$  s

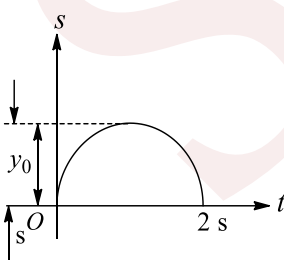

347. A particle moves vertically with an upward initial speed  $v_0 = 10.5 \text{ m/s}$ . If its acceleration varies with time as shown in a  $a - t$  graph in the figure, find the velocity of the particle at  $t = 4$  s



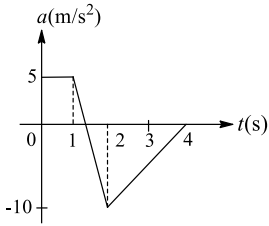

348. From the top of tower of height 80 m, two stones are projected horizontally with  $20 \text{ ms}^{-1}$  and  $30 \text{ ms}^{-1}$  in opposite directions. Find the distance between both the stones on reaching the ground (in  $10^2 \text{ m}$ )
349. A body standing on a long railroad car throws a ball straight upwards. The car is moving on the horizontal road with an acceleration of  $1 \text{ ms}^{-2}$  and the projection velocity in the vertical direction is  $9.8 \text{ ms}^{-1}$ . How far behind the boy will the ball fall on the car? (in metres)?
350. In the figure, find the horizontal velocity  $u$  (in m/s) of a projectile so that it hits the inclined plane perpendicular. Given  $H = 6.25 \text{ m}$

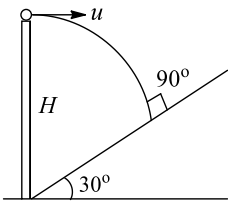

351. A grasshopper can jump maximum distance 0.8 m, while spending negligible time on the ground. How far can it go in 3 s (in m) ( $g = 10 \text{ m/sec}^2$ )?
352. A body is thrown with the velocity  $v_0$  at angle of  $\theta$  to the horizon. Determine  $v_0$  in  $\text{ms}^{-1}$  if the maximum height attained by the body is 5 m and at the highest point of its trajectory the radius of curvature is  $r = 3 \text{ m}$ . Neglect air resistance. [Use  $\sqrt{80}$  as 9]
353. Two bodies 1 and 2 are projected simultaneously with velocities  $v_1 = 2 \text{ m/s}$  and  $v_2 = 4 \text{ m/s}$  respectively. The body 1 is projected vertically up from the top of a cliff of height  $h = 10 \text{ m}$  and the body 2 is projected vertically up from the bottom of the cliff. If the bodies meet, find the time (in s) of meeting of the bodies

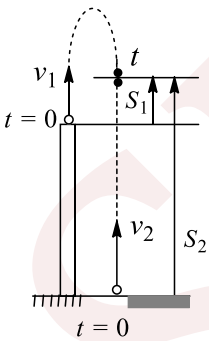

354. A particle is projected up an inclined plane of inclination  $\beta$  at an elevation  $\alpha$  to the horizontal. Find the ratio between  $\tan \alpha$  and  $\tan \beta$ , if the particle strikes the plane horizontally



4.MOTION IN A PLANE

**: ANSWER KEY :**

1) b	2) b	3) b	4) b	165) a	166) a	167) b	168) d	
5) b	6) c	7) c	8) d	169) a	170) c	171) b	172) d	
9) c	10) a	11) b	12) c	173) c	174) a	175) a	176) c	
13) b	14) d	15) a	16) d	177) a	178) d	179) a	180) c	
17) a	18) b	19) d	20) d	181) c	182) b	183) a	184) a	
21) a	22) a	23) a	24) c	185) d	186) b	1) a,c	2)	
25) c	26) d	27) c	28) a	b,c	3) a,b	4) b		
29) b	30) c	31) a	32) d	5) b,c,d	6) a,c,d	7) b,c	8)	
33) a	34) a	35) a	36) c	c,d	9) a,c	10) a,b	11) a,c,d	12) b
37) a	38) a	39) c	40) d	9) a,c	10) a,b	11) a,c,d	12) b	
41) c	42) d	43) b	44) a	13) a,b,c,d	14) b	15) b,c,d	16) d	
45) a	46) b	47) d	48) a	17) b	18) b	19) a,b	20)	
49) b	50) d	51) c	52) c	b,c	21) a,d	22) b,c,d	23) a,d	24)
53) d	54) d	55) c	56) b	21) a,d	22) b,c,d	23) a,d	24)	
57) b	58) b	59) d	60) c	b,d	25) a,d	26) a,c	27) a,b,c	28)
61) d	62) b	63) c	64) a	25) a,d	26) a,c	27) a,b,c	28)	
65) c	66) b	67) c	68) c	b,c	29) d	30) b,c,d	31) a,d	32)
69) a	70) a	71) d	72) b	29) d	30) b,c,d	31) a,d	32)	
73) c	74) b	75) d	76) b	a,c,d	33) a,c,d	34) b,c	35) a,c,d	36)
77) c	78) c	79) d	80) c	33) a,c,d	34) b,c	35) a,c,d	36)	
81) b	82) d	83) c	84) d	b,d	37) c	38) c	39) a,b	40) b
85) d	86) b	87) d	88) a	37) c	38) c	39) a,b	40) b	
89) c	90) a	91) a	92) b	41) b,c,d	42) a	43) c,d	44) a	
93) a	94) b	95) c	96) c	45) b,c,d	46) a,c	47) a,b,d	48) d	
97) d	98) c	99) b	100) d	49) a	50) b,c	51) a,c,d	1) a	
101) b	102) a	103) a	104) a	2) a	3) d	4) a		
105) c	106) d	107) a	108) c	5) c	6) a	7) d	8) a	
109) a	110) a	111) b	112) a	9) a	10) c	11) d	12) d	
113) a	114) b	115) d	116) d	13) c	14) c	15) d	16) a	
117) b	118) b	119) a	120) d	17) a	18) c	19) b	20) d	
121) c	122) a	123) d	124) c	21) a	22) b	23) a	24) a	
125) a	126) b	127) b	128) c	25) b	26) d	27) d	28) a	
129) a	130) b	131) c	132) b	29) b	30) e	31) d	32) d	
133) d	134) b	135) d	136) b	33) c	34) b	35) c	36) c	
137) a	138) c	139) a	140) b	37) a	38) c	39) e	40) e	
141) b	142) d	143) c	144) c	41) b	42) c	43) a	44) c	
145) d	146) a	147) c	148) c	45) d	46) a	47) c	48) a	
149) c	150) c	151) a	152) b	49) c	50) a	51) c	52) c	
153) a	154) c	155) b	156) c	53) c	54) a	55) d	56) a	
157) b	158) d	159) c	160) d	1) c	2) d	3) a	4) b	
161) c	162) d	163) d	164) a	5) a	6) b	7) a	8) b	



9)	c	10)	a	1)	c	2)	b	29)	b	30)	b	1)	2	2)	2
3)	a	4)	b	3)	a	4)	b	3)	4	4)	5	5)	4	6)	9
5)	d	6)	d	7)	c	8)	c	5)	4	6)	9	7)	5	8)	2
9)	b	10)	c	11)	d	12)	c	9)	5	10)	5	11)	7	12)	3
13)	a	14)	c	15)	c	16)	c	13)	0	14)	3	15)	2	16)	2
17)	d	18)	c	19)	c	20)	a	17)	5	18)	6	19)	9	20)	5
21)	a	22)	a	23)	b	24)	b	21)	2						
25)	d	26)	d	27)	a	28)	d								

SENJEE



SENJEE



4.MOTION IN A PLANE

**: HINTS AND SOLUTIONS :**

1 (b)

$$\frac{y}{x} = \tan \beta \Rightarrow \frac{u \sin \alpha t - \frac{1}{2}gt^2}{u \cos \alpha t} = \tan \beta$$

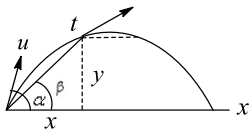

$$\Rightarrow u \sin \alpha - \tan \beta u \cos \alpha = \frac{gt}{2}$$

$$\Rightarrow u = \frac{gt \cos \beta}{2 \sin(\alpha - \beta)}$$

2 (b)

The vertical displacement vs time graph has the same form as the trajectory of the particle

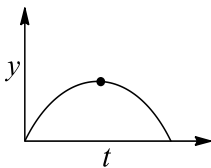

At the topmost point, the slope is zero, but the curvature is non-zero

3 (b)

The situation is as shown in Fig

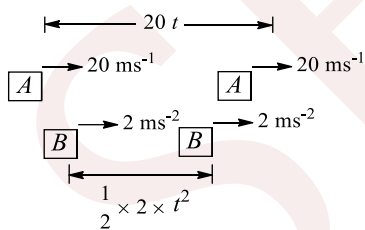

At  $t = 0$                       At  $t = 0$   
Overtaking starts      Overtaking finishes  
From the diagram, we get

$$20t = 10 + \frac{1}{2} \times 2t^2 \Rightarrow t^2 + 10 - 20t = 0$$

$$t = 0.513 \text{ s}, 19.487 \text{ s}$$

Out of these two,  $t_1 = 0.513 \text{ s}$  corresponds to the situation when overtaking has been completed and  $t_2 = 19.487 \text{ s}$  corresponds to the same situation as shown in Fig, but for  $t_1 < t < t_2$  the

separation between two cars first increases and then decreases. Finally B will overtake A

$$\text{Total road distance used} = 5 + 20t_1 = 15.26 \text{ m}$$

4

(b)

$$v_x = u_x = 100 \text{ ms}^{-1}, v_y = u_y + a_y t = 0 + 10 \times 10$$

$$\tan \theta = \frac{v_y}{v_x} = \frac{100}{100} = 1 \Rightarrow \theta = 45^\circ$$

5

(b)

Finally, he will swim along B.  $\tan \theta = \frac{v}{u} = \frac{10}{5} = 2$

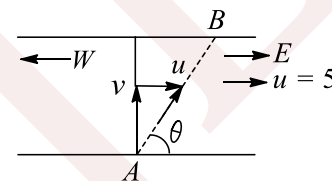

$$\Rightarrow \theta = \tan^{-1}(2) \text{ Nof E}$$

6

(c)

$y = ax - bx^2$ ; for height or y to be maximum:

$$\frac{dy}{dx} = 0$$

$$\text{or } a - 2bx = 0 \text{ or } x = \frac{a}{2b}$$

$$\text{i. } y_{\max} = a \left( \frac{a}{2b} \right) - b \left( \frac{a}{2b} \right)^2 = \frac{a^2}{4b}$$

$$\text{ii. } \left( \frac{dy}{dx} \right)_{x=0} = a = \tan \theta_0, \text{ where } \theta_0 = \text{angle of projection}$$

$$\theta_0 = \tan^{-1}(a)$$

7

(c)

$$y = k\sqrt{x} \Rightarrow y^2 = k^2 x \Rightarrow 2y \frac{dy}{dt} = k^2 \frac{dx}{dt}$$

$$\text{or } 2yv_y = k^2 v_x \dots \text{(i)}$$

$$\text{Also, } v^2 = v_x^2 + v_y^2 \dots \text{(ii)}$$

When  $v_y = v_x$ , from Eqs. (i) and (ii),

$$y = \frac{k^2}{2}, v_x = v_y = \frac{v}{\sqrt{2}}$$

$$\text{Differentiating (i) again, } 2(v_y^2 + ya_y) = k^2 a_x$$

$$\text{or } 2 \left( \frac{v^2}{2} + \frac{k^2}{2} a_y \right) = k^2 a_x \text{ or } v^2 + k^2 a_y = k^2 a_x$$

$$\text{or } a_y - a_x = -\frac{v^2}{k^2}$$



- 8 (d) When the body is dropped from the balloon, it also acquires the upward velocity of balloon. So w.r.t. a person on the ground, the ball appears to be going up. But a person in the balloon is also going up. So w.r.t. him, velocity of body will be zero and he will then see the body to be coming down

9 (c) Average velocity =  $\frac{\text{Displacement}}{\text{Time}} = \frac{\sqrt{H^2 + R^2/4}}{T/2}$

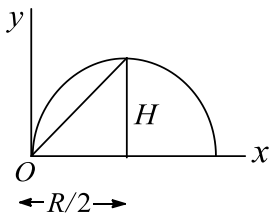

Putting the required values, we get

$$v_{av} = \frac{v}{2} \sqrt{1 + 3 \cos^2 \theta}$$

- 10 (a)  $AC = R/2, PC = H$   
We have to find  $h = MP$   
we know that if  $H = R$ ,

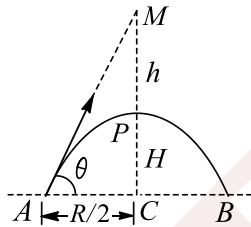

then  $\tan \theta = 4$  Now  $\tan \theta = \frac{MC}{AC} = \frac{MP+PC}{AC}$   
 $4 = \frac{h/H}{R/2} \Rightarrow 4 = \frac{(h+H)2}{H} \Rightarrow h = H$

- 11 (b) Retardation due to friction of air =  $\frac{g}{10}$ . Hence, in upward motion

total retardation  $g_1 = g + \frac{g}{10} = \frac{11g}{10}$

$H_m = \frac{u^2 \sin^2 \theta}{2g}$  and

$H'_m = \frac{u^2 \sin^2 \theta}{2 \times \frac{11g}{10}} = \frac{10}{11} \times \frac{u^2 \sin^2 \theta}{2g} = \frac{10}{11} H_m$

% decreases in  $H_m = \frac{H_m - H'_m}{H_m} \times 100$

$= \left(1 - \frac{10}{11}\right) \times 100 = 9\%$

- 13 (b)

$\vec{v}_2 = \vec{v}_1 - \vec{v}_0, \vec{v}_2 + \vec{v}_0 = \vec{v}_1$

From the law of triangle, we can draw the velocity vector diagram

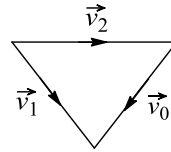

From triangle property, sum of two sides  $\geq$  third side

So  $v_1 \leq v_0 + v_2$

- 14 (d)

$t_{OA} = t_{BC}$

To find  $t_{OA} + t_{OB}$

$t_{OA} + t_{OB} = t_{BC} + t_{OB} = T$

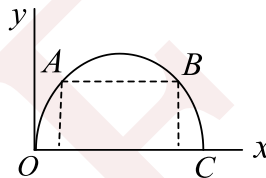

- 15 (a)

A bullet fired at angle  $45^\circ$  will fall maximum away and all other bullets will fall with this bullet fired at  $45^\circ$

$R_{\max} = \frac{u^2}{g}$

Maximum area covered =  $\pi(R_{\max})^2 = \pi \left(\frac{u^2}{g}\right)^2$

- 16 (d)

$h = \frac{u^2 \sin^2 \theta}{2g}$  and  $R = \frac{u^2 \sin 2\theta}{g}$

$\frac{h}{R} = \frac{45}{180} = \frac{\tan \theta}{4}$  or  $\theta = 45^\circ$

- 17 (a)

$u_x = 16 \cos 60^\circ = 8 \text{ ms}^{-1}$

Time taken to reach the wall =  $8/8 = 1 \text{ s}$

Now  $u_y = 16 \sin 60^\circ = 8\sqrt{3} \text{ ms}^{-1}$

$h = 8\sqrt{3} \times 1 - \frac{1}{2} \times 10 \times 1 = 13.86 - 5 = 8.9 \text{ m}$

- 18 (b)

$ma \cos \theta = mg \cos(90 - \theta)$

$\Rightarrow \frac{a}{g} = \tan \theta \Rightarrow \frac{a}{g} = \frac{dy}{dx}$

$\Rightarrow \frac{d}{dx} (kx)^2 = \frac{a}{g} \Rightarrow x = \frac{a}{2gk}$

- 19 (d)

$V^2 = U^2 - 2g(L - L \cos \theta)$

$\frac{5gL}{4} = 5gL - 2gL(1 - \cos \theta)$



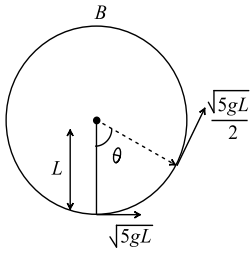

$$5 = 20 - 8 + 8 \cos \theta$$

$$\cos \theta = -\frac{7}{8}$$

$$\frac{3\pi}{4} < \theta < \pi$$

20 (d)

$$t = \frac{a}{v - v \cos \frac{\pi}{n}} \text{ Here } n = 12$$

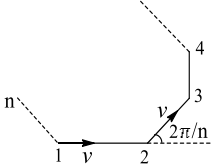

$$\Rightarrow t = \frac{a}{v - v \cos \frac{2\pi}{12}} = \frac{2a}{v(2 - \sqrt{3})}$$

21 (a)

$$\tan \theta = \frac{4H}{R} = \frac{4 \times 4}{12} = \frac{4}{3} \Rightarrow \sin \theta = \frac{4}{5}$$

$$H = \frac{u^2 \sin^2 \theta}{2g} \Rightarrow u = \frac{\sqrt{2gH}}{\sin \theta} = \frac{\sqrt{2 \times g \times 4}}{4/5} = 5\sqrt{\frac{g}{2}}$$

22 (a)

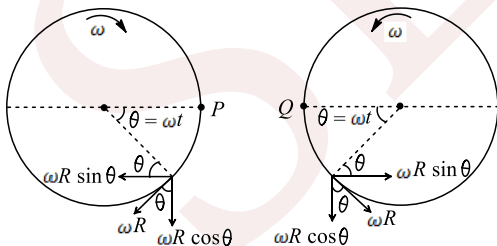

$$\text{So, } V_r = 2\omega R \sin(\omega t)$$

$$\text{At } t = T/2, V_r = 0$$

So two half cycles will take place

23 (a)

A shows time in seconds also, whereas B shows only up to minute. So A is more precise. But time

shown by B is more closer to accurate time, hence, B is more accurate

24 (c)

$$H = \frac{u^2 \sin^2 \theta}{2g} \text{ or } 80 = \frac{u^2 \sin^2 \theta}{2 \times 10}$$

$$\text{or } u^2 \sin^2 \theta = 1600 \text{ or } u \sin \theta = 40 \text{ ms}^{-1}$$

$$\text{Horizontal velocity} = u \cos \theta = 3 \times 30 = 90 \text{ ms}^{-1}$$

$$\frac{u \sin \theta}{u \cos \theta} = \frac{40}{90} \text{ or } \tan \theta = \frac{4}{9} \text{ or } \theta = \tan^{-1} \left( \frac{4}{9} \right)$$

25 (c)

The time taken to reach the ground depends on the height from which the bullets are fired when the bullets are fired horizontally. Here height is same for both the bullets, and hence the bullets will reach the ground simultaneously

26 (d)

$$R = \frac{u^2}{g} \text{ and } H = \frac{u^2 \sin^2 \theta}{2g}$$

for the maximum range,  $\theta = 45^\circ$

$$H = \frac{u^2 \sin^2 45^\circ}{2g} = \frac{u^2}{4g} = \frac{R}{4}$$

28 (a)

$$\text{At } t = 0, v = 0, x = 4/3 \text{ m}$$

$$a = \frac{4 \times 3}{3} - 4 = 0$$

As both the particle velocity and acceleration are zero at  $t = 0$ , it will always remain at rest and hence distance travelled at any time interval would be zero

29 (b)

$$\text{Initially: } \vec{u}_P = 20 \cos 60^\circ \hat{i} + 20 \sin 60^\circ \hat{j}$$

$$= 10\hat{i} + 10\sqrt{3}\hat{j}$$

$$\vec{u} = 20\sqrt{2}[\cos 45^\circ (-\hat{i}) + \sin 45^\circ \hat{j}] = -20\hat{i} + 20\hat{j}$$

Initial relative velocity:

$$\vec{u}_{P/Q} = \vec{u}_P - \vec{u}_Q = 30\hat{i} + (10\sqrt{3} - 20)\hat{j}$$

$$u_{P/Q} = \sqrt{30^2 + (10\sqrt{3} - 20)^2} = 20\sqrt{4 - \sqrt{3}} \text{ ms}^{-1}$$

This relative velocity will remain same till both the particles are in air, because relative acceleration is zero

30 (c)

$$\vec{v}_{r/g} = \vec{v}_r + (-\vec{v}_g)\vec{v}_r - \vec{v}_g = -4\hat{j} - 3\hat{i}$$

$$v_{r/g} = \sqrt{v_r^2 + v_g^2} = \sqrt{16 + 9} \text{ km h}^{-1} = 5 \text{ km h}^{-1}$$

31 (a)



Since velocity is in tangent direction, its component along radial direction is zero

32 (d)

At  $t = 10$  s,

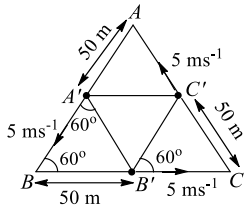

Along the line joining any two  $v_r = 5 \cos 60^\circ - 5 \cos 60^\circ = 0$

33 (a)

In a direction along the inclined plane,

$$0 = V_0 \cos 30^\circ - g \sin 30^\circ t \Rightarrow t = \sqrt{3}V_0/g$$

In a direction perpendicular to incline,

$$-H \cos 30^\circ = -V \sin 30^\circ t - \frac{1}{2}g \cos 30^\circ t^2$$

Putting the value of  $t$  and solving, we get  $V_0 =$

$$\sqrt{\frac{2gH}{5}}$$

34 (a)

Horizontal component of velocity,  $u_H =$

$$u \cos 60^\circ = \frac{u}{2}$$

$$AC = u_H \times t = \frac{ut}{2} \text{ and}$$

$$AB = AC \sec 30^\circ = \left(\frac{ut}{2}\right) \left(\frac{2}{\sqrt{3}}\right) = \frac{ut}{\sqrt{3}}$$

35 (a)

$$\text{Since } R = 2H \text{ or } \frac{v^2 \sin 2\theta}{g} = 2 \times \frac{v^2 \sin^2 \theta}{2g}$$

$$\text{or } 2 \sin \theta \cos \theta = \sin^2 \theta \text{ or } \tan \theta = 2$$

$$R = \frac{v^2 \sin 2\theta}{g} = \frac{v^2 2 \sin \theta \cos \theta}{g} = \frac{2v^2}{g} \times \frac{2}{\sqrt{5}} \times \frac{1}{\sqrt{5}} = \frac{4v^2}{5g}$$

36 (c)

From figure

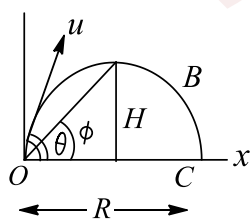

$$\tan \phi = \frac{H}{R/2} = \frac{u^2 \sin^2 \theta / 2g}{u^2 \sin 2\theta / 2g} =$$

$$\frac{\sin^2 \theta}{\sin 2\theta} = \frac{1}{2} \tan \theta$$

37 (a)

Angular velocity is always directed perpendicular to the plane of the circular path. Hence, required change in angle is  $0^\circ$

38 (a)

From graph  $v = s$

$$\Rightarrow \frac{dv}{dt} = \frac{ds}{dt} \Rightarrow a = v$$

Acceleration versus velocity graph will be a straight line passing through origin with slope  $1 \text{ s}^{-1}$

39 (c)

Velocity at the highest point,

$$\vec{v}_h = \hat{i}(u \cos \theta)$$

Velocity at the starting point

$$\vec{v}_s = \hat{i}(u \cos \theta) + \hat{j}(u \sin \theta)$$

$$|\Delta \vec{v}| = |\vec{v}_h - \vec{v}_s| = |-\hat{j}(u \sin \theta)| = u \sin \theta$$

40 (d)

Applying equation of trajectory, we get

$$0.5 = \frac{\sqrt{3}}{2} \tan 30^\circ - \frac{g \left(\frac{\sqrt{3}}{2}\right)}{2v_0^2 \cos^2 30^\circ} \Rightarrow v_0 = \infty$$

41 (c)

$$y_1 = \frac{u^2 \sin^2 \theta}{2g}, y_2 = \frac{u^2 \sin^2(90^\circ - \theta)}{2g} = \frac{u^2 \cos^2 \theta}{2g}$$

$$\Rightarrow y_1 + y_2 = \frac{u^2}{2g}$$

42 (d)

$$\mathbf{L} = m(\mathbf{r} \times \mathbf{v})$$

Direction of  $(\mathbf{r} \times \mathbf{v})$ , hence the direction of angular momentum remains the same.

43 (b)

$$\frac{u^2 \sin 2\theta}{g} = \frac{(u/2)^2 \sin 30^\circ}{g} = \frac{u^2}{8g}$$

$$\therefore \sin 2\theta = \frac{1}{8} \text{ or } \theta = \frac{1}{2} \sin^{-1} \left(\frac{1}{8}\right)$$

44 (a)

Area under  $a - t$  graph gives the change in velocity ( $dv = a dt$ )

$$v_f - v_i = \frac{1}{2} \times 2 \times 4 = 4 \text{ ms}^{-1}$$

$$v_f = v_i + 4 = 2 + 4 = 6 \text{ ms}^{-1}$$

45 (a)

$$t_{AB} = \text{time of flight of projectile} = \frac{2u \sin(\alpha - 30^\circ)}{g \cos 30^\circ}$$

Now component of velocity along the plane becomes zero at point B



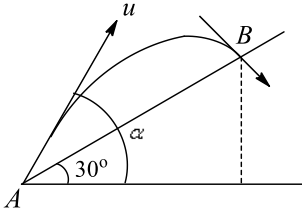

$$0 = u \cos(\alpha - 30^\circ) - g \sin 30^\circ \times T$$

$$\text{or } u \cos(\alpha - 30^\circ) = g \sin 30^\circ \times \frac{2u \sin(\alpha - 30^\circ)}{g \cos 30^\circ}$$

$$\text{or } \tan(\alpha - 30^\circ) = \frac{\cot 30^\circ}{2} = \frac{\sqrt{3}}{2}$$

$$\text{or } \alpha = 30^\circ + \tan^{-1}\left(\frac{\sqrt{3}}{2}\right)$$

46 (b)

The horizontal range is the same for the angles of projection  $\theta$  and  $(90^\circ - \theta)$

$$t_1 = \frac{2u \sin \theta}{g}, t_2 = \frac{2u \sin(90^\circ - \theta)}{g} = \frac{2u \cos \theta}{g}$$

$$t_1 t_2 = \frac{2u \sin \theta}{g} \times \frac{2u \cos \theta}{g} = \frac{2}{g} \left[ \frac{u^2 \sin 2\theta}{g} \right] = \frac{2}{g} R$$

where  $R = \frac{u^2 \sin 2\theta}{g}$

Hence  $t_1 t_2 \propto R$  (as  $R$  is constant)

47 (d)

Angular momentum is an axial vector. It is directed always in a fix direction (perpendicular to the plane of rotation either outward or inward), if the sense of rotation remain same

48 (a)

From  $a = v \frac{dv}{ds}$ , we can find the sign of acceleration at various points.  $v$  is positive for all three points 1, 2 and 3.  $\frac{dv}{ds}$  is positive for point 1, zero for point 2, negative for point 3

So, only for point 1, velocity and acceleration have same sign, so the object is speeding up at point 1 only

50 (d)

We know that to cross the river by the shortest path,

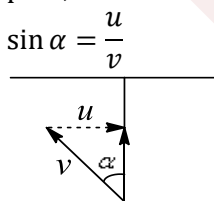

But  $u > v \Rightarrow \sin \alpha > 1$ , which is not possible

51 (c)

The upward motion is with higher retardation, while the downward motion is with lesser acceleration. Further, the time of rise is less than the time of return. A part of the kinetic energy is used against friction

52 (c)

Suppose the angle made by the instantaneous velocity with the horizontal be  $\alpha$ . Then

$$\tan \alpha = \frac{v_y}{v_x} = \frac{u \sin \theta - gt}{u \cos \theta}$$

Given that  $\alpha = 45^\circ$ , when  $t = 1$  s;  $\alpha = 0^\circ$ , when  $t = 2$  s

This gives  $u \cos \theta = u \sin \theta - g \dots (i)$

and  $u \sin \theta - 2g = 0 \dots (ii)$

Solving Eqs. (i) and (ii), we find  $u \sin \theta = 2g$  and  $u \cos \theta = g$ . Squaring and adding

$$u = \sqrt{5g} = 10\sqrt{5} \text{ms}^{-1}$$

53 (d)

$$\frac{1}{2} mu^2 - \frac{1}{2} mv^2 = mgL$$

$$\Rightarrow v = \sqrt{u^2 - 2gL}$$

$$|\vec{v} - \vec{u}| = \sqrt{u^2 + v^2} = \sqrt{u^2 + u^2 - 2gL}$$

$$= \sqrt{2(u^2 - gL)}$$

54 (d)

Speed in horizontal direction remains constant during whole journey because there is no acceleration in this direction. So,  $v_h = 5 \text{ms}^{-1}$

In vertical direction, loss in gravitation potential energy = gain in KE, i.e.,

$$mgh = \frac{1}{2} mv_v^2$$

$$v_v^2 = 2gh = 2 \times 10 \times (70 - 60) = 200$$

Hence, the speed with which he touches the cliff B is

$$v = \sqrt{v_h^2 + v_v^2} = \sqrt{25 + 200} = \sqrt{225} = 15 \text{ms}^{-1}$$

55 (c)

After releasing the string, centripetal acceleration will become zero, due to which the direction of velocity cannot change now and stone flies tangentially

56 (b)

Maximum speed is at  $t = 8$  s



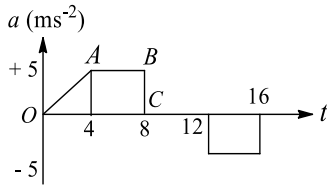

$v$  at  $t = 8$  s is given by area under curve  $OABC$

$$\begin{aligned} \text{Maximum speed} &= \frac{1}{2}(AB + OC) \times BC \\ &= \frac{1}{2} \times (12) \times 5 = 30 \text{ ms}^{-1} \end{aligned}$$

57 (b)

The bird keeps on flying with a constant speed till the time of crash. So let us first find the time of crash. If the two trains crash each other after  $t$  hours, then the total distance travelled by the two trains in the same time of  $t$  hours should be 60 km

$$40t + 60t = 60 \Rightarrow t = \frac{60}{100} = 0.6 \text{ h}$$

Now, the distance travelled by the bird in 0.6 h is  $0.6 \times 30 = 18$  km

58 (b)

$$\frac{R}{T^2} = g \frac{\sin 2\theta}{4 \sin^2 \theta} = \frac{g}{2} \cot \theta = 5 \cot \theta$$

Given  $\frac{R}{T^2} = 5$ ; hence,  $5 = 5 \cot \theta$  or  $\theta = 45^\circ$

59 (d)

If the particles collide in mid air, they travel same displacement in horizontal direction. So their velocity components along horizontal should be same, i.e.,  $v_1 \cos \theta_1 = v_2 \cos \theta_2$

60 (c)

The vertical component goes on decreasing and eventually becomes zero

61 (d)

We find that  $H = R$  or

$$\frac{v^2 \sin^2 \theta}{2g} = \frac{v^2 2 \sin \theta \cos \theta}{g}$$

or  $\tan \theta = 4$  or  $\theta = \tan^{-1}(4)$

62 (b)

We have  $v_{av} = \frac{\text{Displacement}}{\text{Time interval}}$

= Slope of chord on  $x - t$  graph

Here, slope of chord between  $P$  and  $Q$  for all three particles is same, so average velocity of all the three particles would be the same

63 (c)

In general  $h = \frac{1}{2}gt^2$

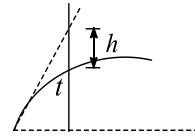

$$\begin{aligned} X &= \frac{1}{2}g(1)^2 = 5 \text{ m}, Y = \frac{1}{2}g(2)^2 = 20 \text{ m}, Z \\ &= \frac{1}{2}g(3)^2 = 45 \text{ m} \end{aligned}$$

64 (a)

We know that

$$x = (u \cos \theta)t \text{ and } y = (u \sin \theta)t - \frac{1}{2}gt^2$$

$$\text{Let } x_2 - x_1 = (u_1 \cos \theta_1 - u_2 \cos \theta_2)t = X$$

$$\begin{aligned} y_2 - y_1 &= (u_1 \sin \theta_1)t - \frac{1}{2}gt^2 - (u_2 \sin \theta_2)t \\ &\quad + \frac{1}{2}gt^2 \end{aligned}$$

$$= (u_1 \sin \theta_1 - u_2 \sin \theta_2)t = Y$$

$$\frac{Y}{X} = \frac{u_1 \sin \theta_1 - u_2 \sin \theta_2}{u_1 \cos \theta_1 - u_2 \cos \theta_2} = \text{constant, } m(\text{say})$$

$$Y = mX$$

It is the equation of a straight line passing through the origin

**Alternatively:** We can think in this way: Relative acceleration of one projectile w.r.t. another projectile will be zero. Hence, the relative velocity of one projectile w.r.t. another will be constant. If velocity is constant, it indicates straight line motion

65 (c)

$$a_x = -g \sin \theta; a_y = -g \cos \theta$$

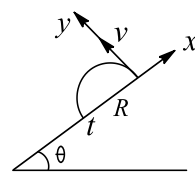

$$u_x = 0; u_y = v$$

$$\text{Along } y\text{-axis, } S_y = u_y t + \frac{1}{2}a_y t^2$$

$$0 = vt - \frac{1}{2}g \cos \theta t^2$$

$$t = \frac{2v}{g \cos \theta}$$

$$\text{Along } x\text{-axis, } S_x = u_x t + \frac{1}{2}a_x t^2$$

$$-R = 0 \times t - \frac{1}{2}g \sin \theta \left( \frac{2v}{g \cos \theta} \right)^2$$

$$-R = \frac{2v^2 \tan \theta \sec \theta}{g}$$

66 (b)



$$t = \frac{2u \sin \theta}{g} \text{ or } 2 = \frac{2u \sin \theta}{g} \text{ or } u \sin \theta = g$$

$$h_m = \frac{u^2 \sin^2 \theta}{2g} = \frac{g^2}{2g} = \frac{g}{2} = 5 \text{ m}$$

67 (c)

Acceleration-velocity equation from the graph is  $a = kv$ , where  $k$  is the slope of given line

This can also be written as

$$v \frac{dv}{ds} = kv \Rightarrow \frac{dv}{ds} = k$$

i.e. slope of velocity-displacement graph is same as slope of acceleration-velocity graph which is constant

68 (c)

$$\text{Resultant velocity} = \sqrt{u^2 + g^2 T^2}$$

69 (a)

$$\vec{v}_c = 25\hat{i}, \vec{v}_{b/c} = 25\sqrt{3}\hat{j}$$

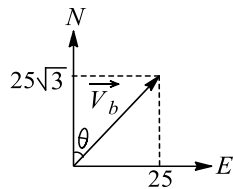

$$\vec{V}_{b/c} = \vec{V}_b - \vec{V}_c \Rightarrow \vec{V}_b = \vec{V}_{b/c} + \vec{V}_c \Rightarrow \vec{v}_b = 25\hat{i} + 25\sqrt{3}\hat{j}$$

$$|\vec{v}_b| = \sqrt{25^2 + (25\sqrt{3})^2} = 50 \text{ km h}^{-1}$$

$$\tan \theta = \frac{25}{25\sqrt{3}} = \frac{1}{\sqrt{3}} \Rightarrow \theta = 30^\circ$$

70 (a)

For particle  $P$ , motion between  $A$  and  $C$  will be an accelerated one while between  $C$  and  $B$  a retarded one. But in any case horizontal component of it's velocity will be greater than or equal to  $v$  on the other hand in case of particle  $Q$ , it is always equal to  $v$ . Horizontal displacement of both the particles are equal, so  $t_p < t_q$

71 (d)

$$\text{Velocity of police van} = 30 \times \frac{5}{18} = \frac{25}{3} \text{ ms}^{-1}$$

$$\text{Muzzle speed of the bullet} = 150 \text{ ms}^{-1}$$

$$\text{Speed of the bullet w.r.t ground} = [150 + (25/3)] \text{ ms}^{-1}$$

Velocity of thief's car is

$$192 \times \frac{5}{18} = \frac{32 \times 5}{3} = \frac{160}{3} \text{ ms}^{-1}$$

Relative velocity of bullet w.r.t. thief's car is

$$150 + \frac{25}{3} - \frac{160}{3} = 150 - \frac{135}{3} = 105 \text{ ms}^{-1}$$

72 (b)

The bullets are fired at the same initial speed.

Hence

$$\frac{h}{h'} = \frac{u^2 \sin^2 60^\circ}{2g} \times \frac{2g}{u^2 \sin^2 30^\circ} = \frac{\sin^2 60^\circ}{\sin^2 30^\circ} = \frac{3}{1}$$

73 (c)

Relative velocity of boat with respect to water is

$$\vec{v}_b - \vec{v}_w = 3\hat{i} + 4\hat{j} - (-3\hat{i} - 4\hat{j}) = 6\hat{i} + 8\hat{j}$$

74 (b)

$$h = \frac{u^2 \sin^2 \theta}{2g} = \frac{(56)^2 \sin^2 \theta}{19.6}$$

$$\sin^2 \theta = \frac{40 \times 19.6}{(56)^2} = \frac{1}{4} \text{ or } \sin \theta = \frac{1}{2} \text{ or } \theta = 30^\circ$$

75 (d)

$$t = \frac{u \sin \theta}{g}, t' = \frac{u \sin \theta}{g'} = \frac{u \sin \theta}{\frac{11g}{10}} = \frac{10}{11} t$$

$$\% \text{ decrease in } t = \frac{t-t'}{t} \times 100 = \left(1 - \frac{10}{11}\right) \times 100 = 9\%$$

76 (b)

$$a = v \frac{dv}{dx} \Rightarrow \int_u^v v dv = \int_0^{1.4} a dx$$

$$\Rightarrow \frac{v^2 - u^2}{2} = \text{area of } a - x \text{ graph}$$

$$\Rightarrow v^2 - (0.8)^2 = 2(0.4) \Rightarrow v = 1.2 \text{ ms}^{-1}$$

77 (c)

Range will be same, because the sum of two angles is  $90^\circ$ . Hence, the ratio is 1 : 1

78 (c)

$$x = 6t, u_x = \frac{dx}{dt} = 6$$

$$y = 8t - 5t^2, v_y = \frac{dy}{dt} = 8 - 10t$$

$$v_y(t=0) = 8 \text{ ms}^{-1}$$

$$u = \sqrt{u_x^2 + u_y^2} = \sqrt{6^2 + 8^2} = 10 \text{ ms}^{-1}$$

79 (d)

Time taken for swimmer for  $(AC + CB)$  = time taken to float for  $AB$

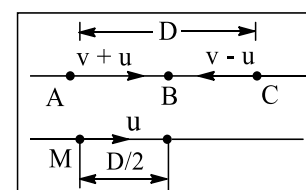

$$\Rightarrow \frac{D}{v+u} + \frac{D}{v-u} = \frac{d/2}{u} \Rightarrow \frac{v}{u} = 3$$



80 (c)  
 $a_c = \frac{v^2}{r} \rightarrow$  constant in magnitude if  $v$  is constant

81 (b)  
 $x^3 = t^3 + 1 \Rightarrow 3x^2 \frac{dx}{dt} = 3t^2 \Rightarrow \frac{dx}{dt} = \frac{t^2}{x^2} \dots(i)$

$$\frac{d^2x}{dt^2} = \frac{2tx^2 - 2x \frac{dx}{dt} t^2}{x^4}$$

$$= \frac{1}{x^4} \left[ 2tx^2 - 2xt^2 \frac{t^2}{x^2} \right]$$

$$= \frac{2tx^2}{x^4} \left[ 1 - \frac{t^3}{x^3} \right] = \frac{2tx^2}{x^4} \left[ 1 - \left\{ \frac{x^3 - 1}{x^3} \right\} \right] = \frac{2t}{x^5}$$

82 (d)  
 $H = \frac{u^2 \sin^2 \theta}{2g}, R = \frac{u^2 \sin 2\theta}{g}$

Maximum height will be same because acceleration  $a = g/4$  is in horizontal direction

$$R' = u \cos \theta T + \frac{1}{2} a T^2 = R + \frac{1}{2} \frac{g}{4} \left( \frac{2u \sin \theta}{g} \right)^2$$

$$= R + H$$

83 (c)  
The magnitude will decrease till the direction of the velocity with respect to man becomes vertical. It will increase thereafter

84 (d)  
If there were no gravity, the bullet would reach height  $H$  in time  $t$  taken by it to travel the horizontal distance  $X$ , i.e.,  $H = u \sin \theta t$  and  $x = u \cos \theta t$  or  $t = \frac{x}{u \cos \theta}$

However, because of gravity the bullet has an acceleration  $g$  vertically downwards, so in time  $t$  the bullet will reach a height

$$y = u \sin \theta \times t - \frac{1}{2} g t^2 = H - \frac{1}{2} g t^2$$

This is lower than  $H$  by  $\frac{1}{2} g t^2$ , which is exactly the amount the monkey falls in this time. So the bullet will hit the monkey regardless of the initial velocity of the bullet so long as it is great enough to travel the horizontal distance to the tree before hitting the ground. (For large  $u$  lesser will be the time of motion; so the monkey is hit near its initial position and for smaller  $u$  it is hit just before it reaches the floor). Bullet will hit the monkey only and only if

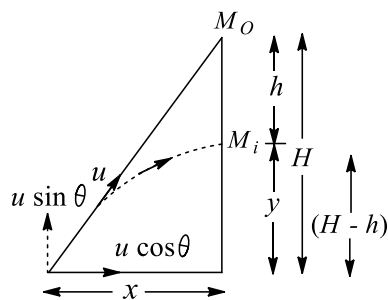

$$y > 0 \text{ i.e., } H - \frac{1}{2} g t^2 > 0$$

$$\text{or } H > \frac{1}{2} g t^2 \text{ or } H > \frac{1}{2} g \frac{x^2}{u^2 \cos^2 \theta}$$

$$\text{or } u > \frac{x}{\cos \theta \sqrt{\frac{g}{2H}}} \text{ or } u > \sqrt{\frac{g}{2H}} (x^2 + H^2) = u_0$$

If  $u < u_0$ , the bullet will hit the ground before reaching the monkey

85 (d)  
 $\frac{h_2}{h_1} = \frac{u^2 \sin^2 \theta_2}{2g} \times \frac{2g}{u^2 \sin^2 \theta_1}$   
 $= \frac{\sin^2 \theta_2}{\sin^2 \theta_1} = \frac{\sin^2 \pi/6}{\sin^2 \pi/3} = \frac{1}{3}$   
 $\Rightarrow h_2 = \frac{h_1}{3}$

86 (b)  
Here,  $u_x = 6$  and  $u_y = 8$   
 $R = \frac{2u_x u_y}{g} = \frac{2 \times 6 \times 8}{10} = 9.6 \text{ m}$

87 (d)  
 $x = 7t - 3t^2 \Rightarrow v = \frac{dx}{dt} = 7 - 6t$

Let us find the time when the velocity becomes zero

$$\text{Putting } v = 0 \Rightarrow 7 - 6t = 0 \Rightarrow t = 7/6 \text{ s}$$

$$x_{(t=7/6s)} = 7 \times \frac{7}{6} - 3 \times \frac{7^2}{6^2} = \frac{49}{12} \text{ m}$$

$$\begin{array}{|c|c|c|} \hline -20 \text{ m} & x = 0 & 49/12 \text{ m} \\ \hline \end{array}$$

$$\text{At } t = 0 \rightarrow x = 0$$

$$\text{At } t = 4 \text{ s} \rightarrow x = 7 \times 4 - 3(4)^2 = -20 \text{ m}$$

$$\text{Distance travelled} = s = \frac{49}{12} + \frac{49}{12} + 20 = \frac{169}{6} \text{ ms}^{-1}$$

$$\text{Av. speed} = \frac{s}{t} = \frac{169}{6 \times 4} = \frac{169}{24} \text{ ms}^{-1}$$

88 (a)  
If the particles collide at  $Q$ , it means they travel same displacement along the plane in same time. So their velocity components along the plane should be same



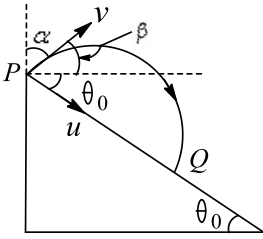

$v \cos(\beta + \theta_0) = u$  and  $\beta = 90^\circ - \alpha$   
Solve to get  $v \sin(\alpha - \theta_0) = u$

89 (c)

Horizontal component of velocity remains constant throughout the motion as it is not affected by acceleration due to gravity, which is directed vertically downwards

90 (a)

$$0.2n = \frac{1}{2}gt^2 \Rightarrow t = \sqrt{\frac{2 \times 0.2n}{g}}$$

$$0.3n = ut \Rightarrow 0.3n = 4.5 \sqrt{\frac{2 \times 0.2n}{g}} \Rightarrow n = 9$$

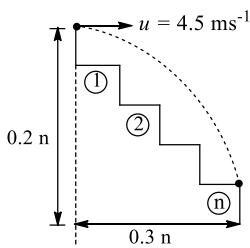

91 (a)

The motion of the train will affect only the horizontal component of the velocity of the ball. Since, vertical component is same for both observers,  $h_m$  will be same, but  $R$  will be different

92 (b)

Range will be same, because the sum of two angles is  $90^\circ$

93 (a)

Change in velocity =  $\vec{v}_f - \vec{v}_i$

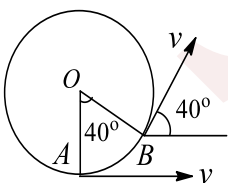

Its magnitude is  $\sqrt{v^2 + v^2 - 2vv \cos 40^\circ} = 2v \sin 20^\circ$

94 (b)

Time taken by bullet to reach the target is

$$\frac{\text{Distance}}{\text{Velocity}} = \frac{\text{Distance}}{u \cos \theta}, \text{ As } \theta \text{ is very small, } \cos \theta = 1$$

$$\text{Time} = \frac{\text{Distance}}{u} = \frac{400}{400} = 1 \text{ s}$$

Vertical deflection of bullet is

$$\frac{1}{2}gt^2 = \frac{1}{2} \times 10 \times (1)^2 = 5 \text{ m}$$

95 (c)

We see that in  $x - t$  graph, initially at  $t = 0$ , slope is negative. Hence, velocity is negative

96 (c)

$$v^2 = u^2 - 2gh \text{ or } u^2 = v^2 + 2gh$$

$$\text{or } u_x^2 + u_y^2 = v_x^2 + v_y^2 + 2gh, u_x = v_x$$

$$\text{So, } u_y^2 = v_y^2 + 2gh \text{ or } u_y^2 = (2)^2 + 2 \times 10 \times 0.4 = 12$$

$$u_y = \sqrt{12} = 2\sqrt{3} \text{ ms}^{-1}, u_x = v_x = 6 \text{ ms}^{-1}$$

$$\tan \theta = \frac{u_y}{u_x} = \frac{2\sqrt{3}}{6} = \frac{1}{\sqrt{3}} \Rightarrow \theta = 30^\circ$$

97 (d)

$T \cos \theta$  component will cancel  $mg$ .

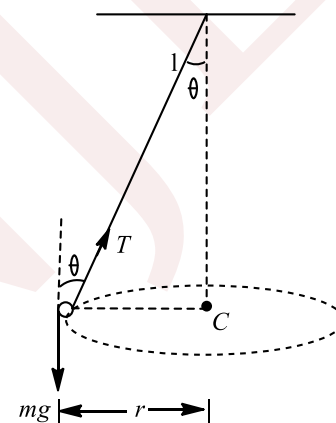

$T \sin \theta$  Component will provide necessary centripetal force the ball towards center  $C$ .

$$\therefore T \sin \theta = mr\omega^2 = m(l \sin \theta)\omega^2$$

$$\text{or } T = ml\omega^2 \Rightarrow \omega = \sqrt{\frac{T}{ml}} \text{ rad/s}$$

$$\text{or } \omega_{\max} = \sqrt{\frac{T_{\max}}{ml}} = \sqrt{\frac{324}{0.5 \times 0.5}} = 36 \text{ rad/s}$$

98 (c)

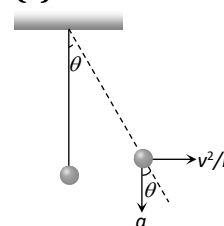

$$\tan \theta = \frac{v^2}{rg}$$

$$\therefore \theta = \tan^{-1} \left( \frac{v^2}{rg} \right) = \tan^{-1} \left( \frac{10 \times 10}{10 \times 10} \right)$$

$$\therefore \theta = \tan^{-1}(1) = 45^\circ$$

99 (b)

$$\sin \alpha = \frac{u}{v} = \frac{\sqrt{3}}{2}$$

$$\Rightarrow \alpha = 60^\circ$$

$$\Rightarrow \theta = 90^\circ + \alpha = 150^\circ$$

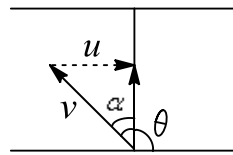

100 (d)

Relative velocity of bird with respect to train is  $V_{BT} = V_B + V_T = 5 + 10 = 15 \text{ ms}^{-1}$

[Because they are going in opposite directions]

time taken by the bird to cross the train is  $\frac{150}{5} = 10 \text{ s}$

101 (b)

For the maximum range  $\theta = 45^\circ$

$$R = \frac{u^2 \sin 2\theta}{g} = \frac{u^2}{g} \sin 90^\circ = \frac{u^2}{g} \text{ or } 500 = \frac{u^2}{g}$$

The distance covered along the inclined plane can be obtained using the equation

$$v^2 - u^2 = 2as$$

$$\text{or } 0 - u^2 = 2(-g \sin 30^\circ)s \text{ or } s = \frac{u^2}{g} = 500 \text{ m}$$

102 (a)

Here,  $v_R = 25 \text{ ms}^{-1}$ ,  $v_w = 10 \text{ ms}^{-1}$

Velocity of rain w.r.t. women:  $v_{R/W} = v_R - v_w$

Let  $v_{R/W}$  make an angle  $\theta$  with vertical, then

$$\tan \theta = \frac{v_w}{v_R} = \frac{10}{25} = 0.4$$

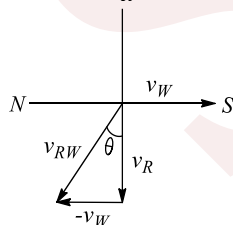

She should hold her umbrella at an angle of  $\theta = \tan^{-1}(0.4)$  with the vertical towards south

103 (a)

Let the stone be projected at an angle  $\alpha$  to the direction of motion of truck with a speed of  $v = 20 \text{ ms}^{-1}$ . Since the resultant displacement along

horizontal is zero, the velocity along horizontal is 0

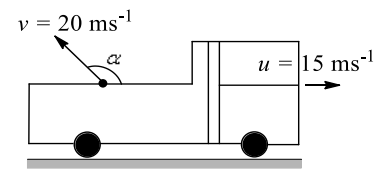

$$15 + 20 \cos \alpha = 0 \Rightarrow \cos \alpha = -\frac{3}{4}$$

$$\Rightarrow \alpha = \cos^{-1} \left( -\frac{3}{4} \right) = 138^\circ 35'$$

104 (a)

$$\frac{h}{T^2} = \frac{u^2 \sin^2 \theta}{2g} \times \frac{g^2}{4u^2 \sin^2 \theta} = \frac{g}{8}$$

$$\text{Thus } \frac{\Delta h}{h} = 2 \frac{\Delta T}{T} \text{ i.e., } \frac{\Delta T}{T} = \frac{1}{2} \frac{\Delta h}{h}$$

$$\text{or } 100 \times \frac{\Delta T}{T} = \frac{1}{2} \left[ \frac{\Delta h}{h} \times 100 \right] = \frac{10}{2} = 5\%$$

105 (c)

$$u = 180 \text{ kmh}^{-1} = 50 \text{ ms}^{-1}$$

$$\text{Horizontal range} = u \sqrt{\frac{2h}{g}} = 50 \sqrt{\frac{2 \times 490}{9.8}} = 500 \text{ m}$$

106 (d)

$$\vec{u} = 20 \cos 30^\circ \hat{i} + 20 \sin 30^\circ \hat{j}$$

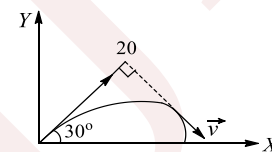

$$\text{Now, } \vec{v} = 20 \cos 30^\circ \hat{i} + (20 \sin 30^\circ - gt) \hat{j}$$

Let  $\vec{v}$  be perpendicular to  $\vec{u}$  at time  $t$ , then

$$\vec{v} \cdot \vec{u} = 0 \Rightarrow t = 4 \text{ s}$$

Here time of flight,  $T = 2 \text{ s}$   
So it is not possible at any instant

107 (a)

$$dM = \left( \frac{M}{L} \right) dx$$

Force on ' $dM$ ' mass is

$$dF = (dM)\omega^2 x$$

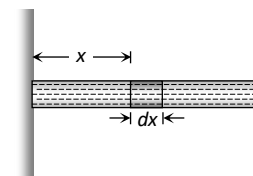

By integration we can get the force exerted by whole liquid

$$\Rightarrow F = \int_0^L \frac{M}{L} \omega^2 x dx = \frac{1}{2} M \omega^2 L$$

108 (c)



Initial relative velocity of A w.r.t. B =  $u - 0 = u$ . It will remain constant till B reaches ground. B stops on colliding with ground, and A comes down with increasing velocity

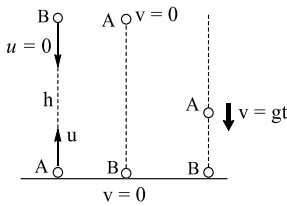

109 (a)

Ris same for both  $\theta$  and  $(90 - \theta)$ . If angle w.r.t. vertical is  $40^\circ$ , then w.r.t. horizontal direction, it will be  $90^\circ - 40^\circ = 50^\circ$

110 (a)

$$R = \frac{u^2 \sin 2\theta}{g} = \frac{(56)^2 \sin 60^\circ}{9.8}$$

$$= \frac{56 \times 56 \times \sqrt{3}}{19.6} = 160\sqrt{3}\text{m}$$

111 (b)

Let at any time  $t$ , the ball be at height of 15 m

$$S_y = u_y t + \frac{1}{2} a_y t^2$$

$$\Rightarrow 15 = u \sin \theta t - \frac{1}{2} g t^2 \Rightarrow 15$$

$$= 52 \times \frac{5}{13} t - \frac{1}{2} \times 10 t^2$$

$$\Rightarrow t^2 - 4t + 3 = 0 \Rightarrow (t - 1)(t - 3) = 0$$

$$\Rightarrow t = 1 \text{ s}, t = 3 \text{ s}. \text{ Required time is } 3 - 1 = 2 \text{ s}$$

112 (a)

$$\vec{v}_p = v\hat{i}, \vec{v}_{b/p} = -u\hat{i}$$

$$\vec{v}_b = \vec{v}_p + \vec{v}_{b/p} = (v - u)\hat{i} = v - u \text{ towards right}$$

113 (a)

In uniform circular motion the only force acting on the particle is centripetal (towards centre). Torque of this force about the centre is zero. Hence angular momentum about centre remains conserved.

114 (b)

Angular acceleration and angular velocity are along the axis of circular path. So they can't be perpendicular to each other

115 (d)

Initial distance between trains is 300 m.

Displacements of trains can be calculated by area under  $V - t$  graph

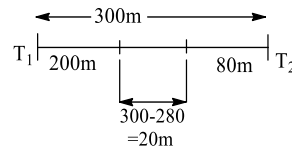

$$\text{Displacement of train 1} = \frac{1}{2} \times 10 \times 40 = 200 \text{ m}$$

$$\text{Displacement of train 2} = \frac{1}{2} \times 8 \times (-20) = -80 \text{ m}$$

Which means it moves towards left

Hence, distance between the two is  $300 - 200 - 80 = 20 \text{ m}$

116 (d)

Refer to Fig (a)

$$\tan \theta = \frac{v_w}{v_m} = \frac{50}{100} = \frac{1}{2} \text{ or } v_m = 2 v_w$$

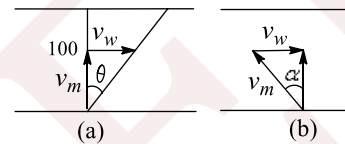

Refer to Fig (b)

$$\sin \alpha = \frac{v_w}{v_m} = \frac{v_w}{2v_w} = \frac{1}{2} \text{ or } \theta = 30^\circ$$

So, it is  $60^\circ$  upstream

117 (b)

Here the tangential acceleration also exists which requires power

$$\text{Given that } a_c = k^2 r t^2 \text{ and } a_c = \frac{v^2}{r} \therefore \frac{v^2}{r} = k^2 r t^2$$

$$\text{Or } v^2 = k^2 r^2 t^2 \text{ or } v = k r t$$

$$\text{Tangential acceleration } a = \frac{dv}{dt} = k r$$

$$\text{Now force } F = m \times a = m k r$$

$$\text{So power } P = F \times v = m k r \times k r t = m k^2 r^2 t$$

118 (b)

$$\text{Given } y = 12x = \frac{3}{4} x^2, u_x = 3 \text{ ms}^{-1}$$

$$v_y = \frac{dy}{dt} = 12 \frac{dx}{dt} = \frac{3}{2} x \frac{dx}{dt}$$

$$\text{At } x = 0, v_y = u_y = 12 \frac{dx}{dt} = 12 u_x = 12 \times 3 = 36 \text{ ms}^{-1}$$

$$a_y = \frac{d}{dt} \left( \frac{dy}{dt} \right) = 12 \frac{d^2 x}{dt^2} = \frac{3}{2} \left( \left( \frac{dx}{dt} \right)^2 + x \frac{d^2 x}{dt^2} \right)$$

$$\text{But } \frac{d^2 x}{dt^2} = a_x = 0, \text{ hence}$$

$$a_y = -\frac{3}{2} \left( \frac{dx}{dt} \right)^2 = -\frac{3}{2} u_x^2 = -\frac{3}{2} \times (3)^2$$

$$= -\frac{27}{2} \text{ ms}^{-2}$$



$$\text{Range } R = \frac{2u_x u_y}{a_y} = \frac{2 \times 3 \times 36}{27/2} = 16 \text{ m}$$

**Alternatively:** We have  $y = 12x - \frac{3}{4}x^2$ . When projectile again comes to ground,  $y = 0$  and  $x = R$   
 $0 = 12R - \frac{3}{4}R^2 \Rightarrow R = 16 \text{ m}$

119 (a)

$$\text{Here } H'_m = \frac{u^2 \sin^2 \theta}{2 \times \frac{11g}{10}} = \frac{10u^2 \sin^2 \theta}{22g}$$

Using  $x = ut + \frac{1}{2}at^2$ , where  $x = H'_m$ ,  $u = 0$  and

$$a = g - \frac{g}{10} = \frac{9g}{10}; \text{ we find } t = \sqrt{2H'_m/a} = \sqrt{\frac{200}{198}} \times \frac{u \sin \theta}{g}$$

It is almost equal to the time of fall in the absence of friction

120 (d)

Acceleration remains constant, and equal to  $g$  always

121 (c)

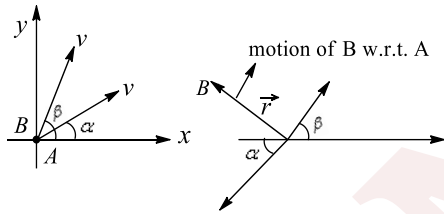

A is fixed and B moves in the direction as shown in Fig. w.r.t. A with constant velocity

Direction of  $\vec{r}$  remains same and magnitude changes with time linearly

Here velocity of B w.r.t. A is constant because relative acceleration is zero

122 (a)

$$r = 1 \text{ km} = 1000 \text{ m},$$

$$v = 900 \text{ kmh}^{-1} = 900 \times \frac{5}{18} = 250 \text{ ms}^{-1}$$

$$a_c = \frac{v^2}{r} = \frac{(250)^2}{1000} = 62.5 \text{ ms}^{-2}$$

123 (d)

Velocity of the bob at the point A

$$v = \sqrt{5gL} \dots (i)$$

$$\left(\frac{v}{2}\right)^2 = v^2 - 2gh \dots (ii)$$

$$h = L(1 - \cos \theta) \dots (iii)$$

Solving Eqs. (i), (ii) and (iii), we get

$$\cos \theta = -\frac{7}{8}$$

$$\text{or } \theta = \cos^{-1}\left(-\frac{7}{8}\right) = 151^\circ$$

124 (c)

We know that at the uppermost point of a projectile, the vertical component of the velocity becomes zero, while the horizontal component remains constant. The acceleration due to gravity is always vertically downwards. Therefore, at the uppermost point of a projectile, its velocity and acceleration are at an angle of  $90^\circ$

125 (a)

For the person to be able to catch the ball, the horizontal component of velocity of the ball should be same as the speed of the person, i.e.,  
 $v_0 \cos \theta = \frac{v_0}{2}$  or  $\cos \theta = \frac{1}{2}$  or  $\theta = 60^\circ$

126 (b)

In this case, velocity and acceleration are acting in opposite directions and velocity is getting zero at  $t = 4 \text{ s}$

$$\begin{aligned} \text{Distance travelled in } 10 \text{ s} &= (\text{Distance travelled in } 0 - 4\text{s}) + (\text{Distance travelled in } 4 - 10 \text{ s}) \\ &= \left[4 \times 4 - \frac{1}{2} \times 1 \times (4)^2\right] + \left[0 \times 6 + \frac{1}{2} \times 1 \times (6)^2\right] \\ &= 26 \text{ m} \end{aligned}$$

127 (b)

$$\text{Speed of train} = 108 \times \frac{5}{18} = 30 \text{ ms}^{-1}$$

Let  $\vec{V}_R$  and  $\vec{V}_T$  represent the respective velocities of rain and train

Now, the relative velocity of rain w.r.t. person (train) is given by  $v_{R,T} = \vec{v}_R - \vec{v}_T \Rightarrow \vec{v}_R + (-\vec{v}_T)$

Let  $\vec{OR}$  and  $\vec{RT}$  represent the vectors, respectively, in magnitude and direction

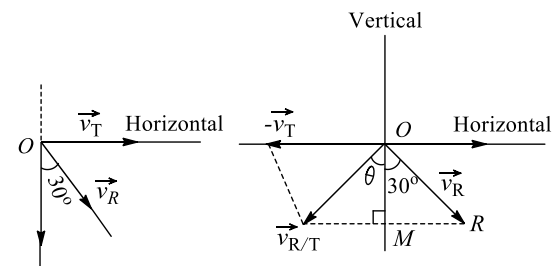

$$\begin{aligned} OT^2 &= OR^2 + RT^2 + 2 OR \cdot RT \cos 120^\circ \\ &= 20^2 + 30^2 - 2 \times 20 \times 30 \times \frac{1}{2} \\ &= 400 + 900 - 600 = 700 = \sqrt{700} \text{ ms}^{-1} \\ &= 10\sqrt{7} \text{ ms}^{-1} \end{aligned}$$

128 (c)



At the two points of the trajectory during projectile motion, the horizontal component of the velocity is same. Then

$$150 \times \frac{1}{2} = v \times \frac{1}{\sqrt{2}} \text{ or } v = \frac{150}{\sqrt{2}} \text{ ms}^{-1}$$

$$\text{Initially: } u_y = u \sin 60^\circ = \frac{150\sqrt{3}}{2} \text{ ms}^{-1}$$

$$\text{Finally: } v_y = v \sin 45^\circ = \frac{150}{\sqrt{2}} \times \frac{1}{\sqrt{2}} = \frac{150}{2} \text{ ms}^{-1}$$

$$\text{But } v_y = u_y + a_y t \text{ or } \frac{150}{2} = \frac{150\sqrt{3}}{2} - 10t$$

$$10t = \frac{150}{2}(\sqrt{3} - 1) \text{ or } t = 7.5(\sqrt{3} - 1)$$

129 (a)

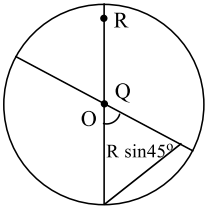

To reach the unshaded portion particle  $P$  needs to travel horizontal range greater than  $R \sin 45^\circ$  or  $(0.7R)$  but its range is less than  $\frac{R}{2}$ . So it will fall on shaded portion

$Q$  is near to origin, its velocity will be nearly along  $QR$  so its will fall in unshaded portion

130 (b)

$$H = 100 \text{ m, } R = 2 \times 200 = 400 \text{ m}$$

$$\tan \theta = \frac{4H}{R} \Rightarrow \tan \theta = \frac{4 \times 100}{400} = 1$$

$$\Rightarrow \theta = 45^\circ \left[ \because \frac{H}{R} = \frac{\tan \theta}{4} \right]$$

131 (c)

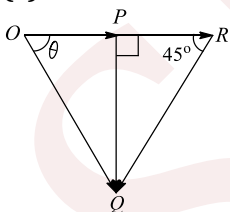

**Case I:** Let  $OP = 3\hat{i}$  be the velocity of man.  $\vec{OQ}$  be the velocity of rain

$PQ$  is the velocity of rain relative to man

**Case II:**  $\vec{OR} = 6\hat{i}$  is the new velocity of man

$\vec{RQ}$  = new velocity of rain relative to man

$$OP = PR = PQ = 3$$

$$\text{Now } OQ^2 = OP^2 + PQ^2 \text{ i.e., } OQ^2 = 3^2 + 3^2$$

$$\text{i.e., } OQ = 3\sqrt{2} \text{ km h}^{-1}$$

$$\text{and } \tan \theta = \frac{PQ}{OP} = \frac{3}{3} = 1 \text{ i.e., } \theta = 45^\circ$$

132 (b)

$$v = t^2 - t \Rightarrow a = \frac{dv}{dt} = 2t - 1$$

For retardation,  $av < 0$

$$\Rightarrow (t^2 - t)(2t - 1) < 0 \Rightarrow t(t - 1)(2t - 1) < 0$$

This is possible for  $\frac{1}{2} < t < 1$

133 (d)

We know that  $H = \frac{u^2 \sin^2 \theta}{2g}$  and  $T = \frac{2u \sin \theta}{g}$ . From these two equations, we get

$$H = \frac{gT^2}{8}. \text{ So if } T \text{ doubled, } H \text{ becomes four times}$$

134 (b)

$$a = \frac{v dv}{dS} = 4 + 3v$$

$$\int dS = \int \frac{v dv}{4 + 3v}$$

$$S = \frac{v}{3} - \frac{4}{9} \log_e(4 + 3v) + C$$

$$\text{At } S = 0, v = 0, \text{ we get } C = \frac{4}{9} \log_e 4$$

$$\Rightarrow S = \frac{v}{3} + \frac{4}{9} \log_e \left( \frac{4}{4 + 3v} \right)$$

Putting  $v = 2 \text{ ms}^{-1}$ , we get

$$S = \frac{2}{3} + \frac{4}{9} \log_e \frac{4}{10} = 0.27 \text{ m}$$

135 (d)

Angle of projection from B is  $45^\circ$ . As the body is able to cross the well of diameter 40 m, hence  $R = \frac{v^2}{g}$  or  $v = \sqrt{gR} = \sqrt{10 \times 40} = 20 \text{ ms}^{-1}$

On the inclined plane, the retardation is

$$g \sin \alpha = g \sin 45^\circ = 10/\sqrt{2} \text{ ms}^{-2}$$

$$\text{Using } v^2 - u^2 = 2ax$$

$$(20)^2 - u^2 = 2 \times \left( -\frac{10}{\sqrt{2}} \right) \times 20\sqrt{2}$$

$$u = 20\sqrt{2} \text{ ms}^{-1}$$

136 (b)

$$v_y = v \sin 30^\circ - g \cos 30^\circ t$$

$$t = \frac{v \sin 30^\circ}{g \cos 30^\circ} = \frac{v}{g\sqrt{3}} = \frac{1}{\sqrt{3}} \text{ s}$$

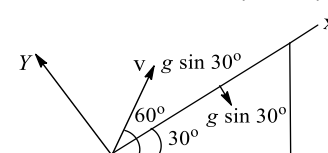

137 (a)

If  $h$  is the maximum height attained by the projectile, then



$$h = \frac{u^2 \sin^2 \theta}{2g} \text{ or } R = \frac{u^2 \sin 2\theta}{g}$$

$$\frac{R}{h} = \frac{2 \sin \theta \cos \theta}{(\sin^2 \theta)/2} = 4 \cot \theta \therefore \frac{\Delta R}{R} = \frac{\Delta h}{h}$$

Percentage increase in  $R$  = percentage increase in  $h = 5\%$

138 (c)

The acceleration vector shall change the component of velocity  $u_{||}$  along the acceleration vector

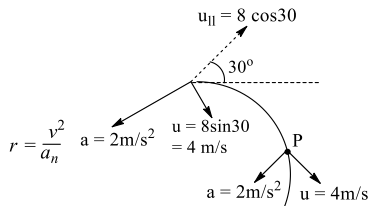

Radius of curvature  $r_{\min}$  means  $v$  is minimum and  $a_n$  is maximum. This is at point  $P$  when the component of velocity parallel to acceleration vector becomes zero, that is  $u_{||} = 0$

139 (a)

The time of flight is given by

$$T = \frac{2u \sin \theta}{g} = \frac{2 \times 30 \times 1/2}{10} = 3 \text{ s}$$

Thus, after 1.5 s the body will be at the highest point. So the direction of motion will be horizontal after 1.5s, the angle with the horizontal is  $0^\circ$

140 (b)

$$\tan \theta = \frac{v_y}{v_x} = \frac{8}{6} = \frac{4}{3} \text{ or } \theta = \tan^{-1} \frac{4}{3}$$

141 (b)

At 12 s, slope of  $B$  is same as that of  $A$

142 (d)

Speed at the highest point =  $u \cos \theta$

Speed at the starting point =  $u$

Hence, change in speed =  $(u \cos \theta - u)$

143 (c)

$$v_y = gT$$

144 (c)

$$x = v \sqrt{\frac{2h}{g}}, 2x = v' \sqrt{\frac{2(2h)}{g}} \text{ Solve to get } v' = \sqrt{2}v$$

145 (d)

$$v_1 = v_2 \cos \beta = u \cos \theta$$

$$0 = (v_2 \sin \beta)^2 - 2g(H/2) \Rightarrow v_1^2 = v_2^2 - gH$$

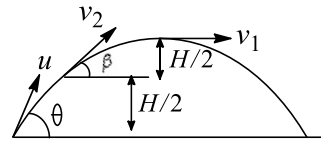

$$\text{Also } \frac{v_1}{v_2} = \sqrt{\frac{2}{5}}$$

$$\text{From above } v_1 = \sqrt{\frac{2gH}{3}}, v_2 = \sqrt{\frac{5gH}{3}}$$

$$H = \frac{u^2 \sin^2 \theta}{2g} \Rightarrow \sin^2 \theta = \frac{2gH \cos^2 \theta}{v_1^2}$$

$$\Rightarrow \tan^2 \theta = \frac{2gH}{v_1^2} \Rightarrow \tan^2 \theta = \frac{2gH \times 3}{2gH}$$

$$\Rightarrow \tan \theta = \sqrt{3} \Rightarrow \theta = 60^\circ$$

146 (a)

Acceleration w.r.t. platform is  $g + a$

$$\text{So time taken } T = \frac{2u \sin \theta}{g+a}$$

147 (c)

Here angle of projection =  $45^\circ$

$$R_{\max} = 1.6 = \frac{u^2}{g} = \frac{u^2}{10} \text{ or } u = 4 \text{ ms}^{-1}$$

Hence, the distance covered in 10 s is horizontal speed  $\times$  time =  $u \cos 45^\circ \times$  time

$$= 4 \times \frac{1}{\sqrt{2}} \times 10 = 20\sqrt{2} \text{ m}$$

148 (c)

Vertical component of both should be same

$$v_2 = v_1 \sin 30^\circ \Rightarrow \frac{v_2}{v_1} = \frac{1}{2} = 0.5$$

149 (c)

$$u_x = u, u_y = 0, v_x = u_x = u$$

$$v_y = u_y + a_y t = 0 + gt = gt$$

$$\text{Resultant velocity } v = \sqrt{v_x^2 + v_y^2} = \sqrt{u^2 + g^2 t^2}$$

150 (c)

$$v \cos 45^\circ = u = 18 \text{ ms}^{-1} \Rightarrow v = 18\sqrt{2} \text{ ms}^{-1}$$

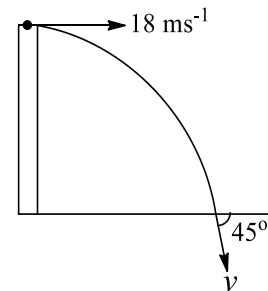

$$\text{Vertical component } v \sin 45^\circ = 18\sqrt{2} \times \frac{1}{\sqrt{2}} = 18 \text{ ms}^{-1}$$



151 (a)

In the absence of air resistance, the projectile moves with constant horizontal velocity because acceleration due to gravity is totally vertical

152 (b)

$$h = 150 - 27.5 = 122.5 \text{ m}$$

$$\text{Time taken, } T = \sqrt{\frac{2h}{g}} = \sqrt{\frac{2 \times 122.5}{9.8}} = 5 \text{ s}$$

$$\text{Now, } s = uT \text{ or } 30 = 5u \text{ or } u = 6 \text{ ms}^{-1}$$

153 (a)

$$\text{Given } h = 490 \text{ m, } u = 15 \text{ ms}^{-1}. \text{ Apply } T = \sqrt{\frac{2h}{g}}$$

154 (c)

The velocity of motor boat is given as

$$\vec{v}_m = \vec{v}_{mw} + \vec{v}_w$$

$$\frac{5}{\sin \theta} = \frac{5\sqrt{3}}{\sin 120^\circ} \Rightarrow \sin \theta = 1/2 \Rightarrow \theta = 30^\circ$$

155 (b)

From the graph, velocity-displacement equation can be written as

$$v = v_0 + \alpha x \quad (\text{i})$$

Here  $v_0$  and  $\alpha$  are positive constants

Differentiating (i) with respect to  $x$ , we get

$$\frac{dv}{dx} = \alpha = \text{constant}$$

Acceleration of the particle can be written as

$$a = v \frac{dv}{dx} = (v_0 + \alpha x)\alpha$$

The  $a - x$  equation is a linear equation. Thus acceleration increases linearly with  $x$

156 (c)

$$u_1 \cos \alpha = u_2 \cos \beta$$

$$30\sqrt{3} = \frac{u_2^2 \sin 2\beta}{g} \Rightarrow 30\sqrt{3} = \frac{u_2^2 \sqrt{3}}{2g}$$

$$\Rightarrow u_2^2 = 600 \Rightarrow u_2 = 10\sqrt{6}$$

$$t_2 = \frac{2u_2 \sin 60^\circ}{g} = \frac{2(10\sqrt{6})\sqrt{3}/2}{10} \Rightarrow t_2 = \sqrt{18}$$

$$u_1 = \frac{10\sqrt{6} \cos 60^\circ}{\cos 30^\circ} = 10\sqrt{2}$$

$$-h = 10\sqrt{2} \sin 30^\circ \sqrt{18} - \frac{1}{2} 10(\sqrt{18})^2$$

$$-h = 30 - 90 \Rightarrow h = 60 \text{ m}$$

157 (b)

Since wind is blowing due north, rain velocity will have a component of  $2 \text{ ms}^{-1}$  due north. So the velocity of cyclist should be  $2 \text{ ms}^{-1}$  due north so that to him rain appears falling vertically. Because

due to this, cyclist will not be able to see the horizontal component of rain's velocity and he will see only vertical component

158 (d)

$$\alpha = (\omega_2 - \omega_1)/t = (400 - 100)/5 = 60 \text{ revmin}^{-2}$$

$$= \frac{60 \times 2\pi}{(60)^2} = \frac{2\pi}{60} \text{ rad s}^{-2}$$

$$a_t = \alpha r = \frac{2\pi}{60} \times \frac{50}{100} = \frac{\pi}{60} \text{ ms}^{-2}$$

159 (c)

$$a_t = 2 \text{ ms}^{-2}, v = u + a_t t = 1 + 2 \times 2 = 5 \text{ ms}^{-1}$$

$$a_c = \frac{v^2}{r} = \frac{5^2}{25} = 1 \text{ ms}^{-2}$$

$$\text{Net acceleration} = \sqrt{a_c^2 + a_t^2} = \sqrt{1^2 + 2^2} = \sqrt{5} \text{ ms}^{-2}$$

160 (d)

First find that time in which the vehicle stops

$$\text{From } \vec{v} = \vec{u} + \vec{a}t \Rightarrow 0 = 20 - 0.5t \Rightarrow t = 40 \text{ s}$$

So the vehicle stops in less than 50 s. The distance covered by the vehicle in 40 s would be

$$s = 20 \times 40 - \frac{1}{2} \times 0.5 \times (40)^2 = 800 - 400 = 400 \text{ m}$$

$$\text{Required distance} = 500 - 400 = 100 \text{ m}$$

161 (c)

$$\vec{r} = x\hat{i} + y\hat{j}$$

$$\vec{v} = \frac{d\vec{r}}{dt} = \frac{dx}{dt}\hat{i} + \frac{dy}{dt}\hat{j} = v_x\hat{i} + v_y\hat{j}$$

If  $\vec{r}$  and  $\vec{v}$  are in opposite directions, then definitely the particle will be moving towards origin  $O$ , for this  $\vec{r} \cdot \vec{v} < 0 \Rightarrow xv_x + yv_y < 0$

162 (d)

$$\frac{R}{T^2} = \frac{u^2 \sin 2\theta/g}{4u^2 \sin^2 \theta/g^2} = \frac{g}{2} \cot \theta$$

$$\text{i.e., } gT^2 = 2R \tan \theta$$

If  $T$  is doubled, then  $R$  becomes 4 times

163 (d)

Range is same for angles of projection  $\theta$  and  $90 - \theta$ ,

$$R = \frac{u^2 \sin 2\theta}{g}, h_1 = \frac{u^2 \sin^2 \theta}{2g}$$

$$\text{and } h_2 = \frac{u^2 \sin^2(90-\theta)}{2g} = \frac{u^2 \cos^2 \theta}{2g}$$

$$\text{Hence } \sqrt{h_1 h_2} = \frac{u^2 \sin \theta \cos \theta}{2g} = \frac{1}{4} \left[ \frac{u^2 \sin 2\theta}{g} \right] = \frac{R}{4}$$

164 (a)



Motion of the person making an angle (say  $\alpha$ ) with the downstream

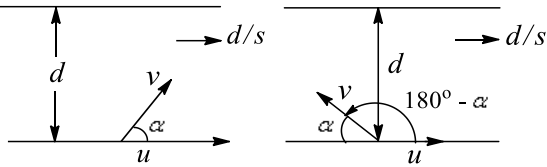

The time taken to cross the river =  $\frac{d}{v \sin \alpha}$

The distance carried away downstream in the same time = speed  $\times$  time

$$x_1 = (u + v \cos \alpha) \frac{d}{v \sin \alpha} \dots(i)$$

Motion of the person making  $\alpha$  angle with upstream

The time taken to cross the river is equal to  $\frac{d}{v \sin \alpha}$

Distance carried away downstream in the same time

$$x_2 = [u + v \cos(180^\circ - \alpha)] \frac{d}{v \sin \alpha}$$

$$\Rightarrow x_2 = (u - v \cos \alpha) \frac{d}{v \sin \alpha} \dots(ii)$$

$$\text{Given } \frac{(u+v \cos \alpha) \frac{d}{v \sin \alpha}}{(u-v \cos \alpha) \frac{d}{v \sin \alpha}} = \frac{2}{1}$$

$$\frac{(u + v \cos \alpha)}{(u - v \cos \alpha)} = \frac{2}{1} \Rightarrow 3v \cos \alpha = u$$

$$\Rightarrow \frac{v}{u} = \frac{\sec \alpha}{3} \dots(iii)$$

$$\sec \alpha \geq 1 \Rightarrow \frac{\sec \alpha}{3} \geq \frac{1}{3}$$

From Eq. (iii),  $\frac{v}{u} \geq \frac{1}{3}$  So,  $v/u$  cannot be less than  $1/3$

165 (a)

Time taken by particles to collide

$$t = \sqrt{\frac{2H}{g}} \text{ then } u \sqrt{\frac{2H}{g}} + V \sqrt{\frac{2H}{g}} = d$$

$$\Rightarrow u + V = d \sqrt{\frac{g}{2H}} \therefore v = d \sqrt{\frac{g}{2H}} - u$$

166 (a)

$$\text{Shortest time} = \frac{d}{v} = \frac{1/2}{3} = \frac{1}{6} \text{ h} = 10 \text{ min}$$

167 (b)

$$T = \frac{100}{25} = 4 \text{ s} \Rightarrow \frac{2u \sin \theta}{g} = 4$$

$$\Rightarrow u \sin \theta = 20 \text{ ms}^{-1}$$

168 (d)

$$\text{Let } u_x = 3 \text{ ms}^{-1}, a_x = 0$$

$$v_y = u_y + a_y t = 0 + 1 \times 4 = 4 \text{ ms}^{-1}$$

$$v = \sqrt{v_x^2 + v_y^2} = \sqrt{3^2 + 4^2} = 5 \text{ ms}^{-1}$$

Angle made by the resultant velocity w.r.t. direction of initial velocity, i.e.  $x$ -axis, is

$$\beta = \tan^{-1} \frac{v_y}{v_x} = \tan^{-1} \frac{4}{3}$$

169 (a)

Let  $d$  be the river width and  $u$  and  $v$  the speed of water current. For  $P$ , time taken

$$t_1 = \frac{2d}{\sqrt{v^2 - u^2}} \dots(i)$$

$$\text{For } Q, \text{ time taken } t_2 = d \left[ \frac{1}{v+u} + \frac{1}{v-u} \right] \dots(ii)$$

Dividing (i) by (ii), we get

$$\frac{t_1}{t_2} = \sqrt{1 - \left(\frac{u}{v}\right)^2} < 1 \Rightarrow t_1 < t_2$$

170 (c)

To find the relative velocity of bird w.r.t. train, superimpose velocity  $-\vec{V}_T$  on both the object. Now as a result of it, the train is at rest, while bird possesses two velocities,  $\vec{V}_B$  towards north and  $\vec{V}_T$  along west

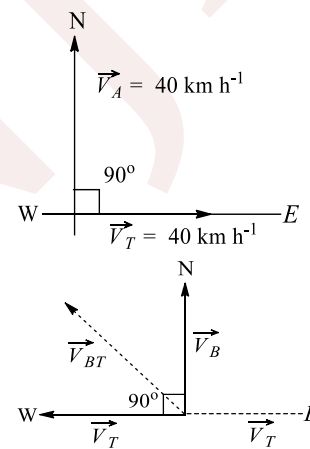

$$|\vec{V}_{BT}| = \sqrt{|\vec{V}_B|^2 + |-\vec{V}_T|^2} \text{ [By formula, } \theta = 90^\circ]$$

$$= \sqrt{40^2 + 40^2} = 40\sqrt{2} \text{ km h}^{-1} \text{ north-west}$$

171 (b)

$$t = \frac{2u \sin \theta}{g} \text{ or } 2 = \frac{2u \sin \theta}{g} \Rightarrow u \sin \theta = g$$

$$h_m = \frac{u^2 \sin^2 \theta}{2g} = \frac{g^2}{2g} = \frac{g}{2} = 5 \text{ m}$$

172 (d)

$$\text{We know that } a = \frac{dv}{dt} \Rightarrow \int dv = \int a dt$$

R.H.S of above expression represents area under acceleration time graph



Area of acceleration graph is not getting zero over the interval for which graph is given, hence velocity is not getting zero again over the interval

173 (c)

If the ball hits the  $n$ th step, then horizontal distance transversed =  $nh$ . Here, velocity along horizontal direction =  $u$ .  $n = ut \dots(i)$   
Initial velocity along vertical direction is 0

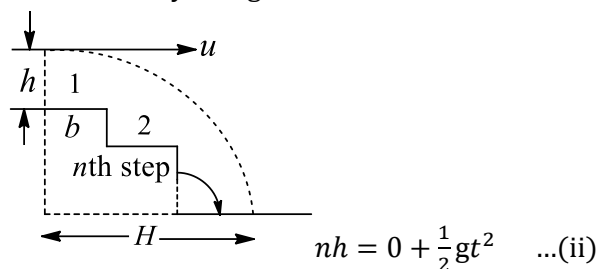

From  $t = \frac{nb}{v}$  putting  $t$  in (ii)

$$nh = \frac{1}{2}g \times \left(\frac{nb}{u}\right)^2 \text{ or } n = \frac{2hu^2}{gb^2}$$

174 (a)

It is obvious from considerations of symmetry that at any moment of time all of the persons will be at the corners of square whose side gradually decreases (see fig.) and so they will finally meet at the centre of the square  $O$

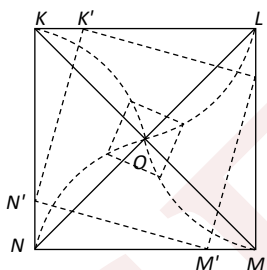

The speed of each person along the line joining his initial position and  $O$  will be  $v \cos 45 = v/\sqrt{2}$

As each person has displacement  $d \cos 45 = d/\sqrt{2}$  to reach the centre, the four persons will meet at the centre of the square  $O$  after time

$$\therefore t = \frac{d/\sqrt{2}}{v/\sqrt{2}} = \frac{d}{v}$$

175 (a)

For  $B$  always to be north of  $A$ , the velocity components of both along east should be same

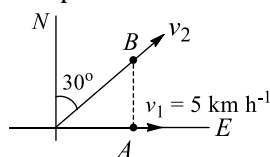

$$v_2 \cos 60^\circ = v_1 \Rightarrow v_2 = 10 \text{ km h}^{-1}$$

176 (c)

$$v_x = \frac{dx}{dt} = 6 \text{ and } v_y = \frac{dy}{dt} = 8 - 10t$$

Putting  $t = 0$  (Since we have to find initial velocity)

$$v_y = 8 - 10 \times 0 = 8$$

$$v = \sqrt{v_x^2 + v_y^2} = \sqrt{6^2 + 8^2} = 10 \text{ ms}^{-1}$$

177 (a)

$$a = v \frac{dv}{ds} = 4 \times (-\tan 60^\circ) = -4\sqrt{3} \text{ ms}^{-2}$$

178 (d)

$$\text{Range} = 150 = ut \text{ and } h = \frac{15}{100} = \frac{1}{2} \times gt^2$$

$$\text{or } t^2 = \frac{2 \times 15}{100 \times g} = \frac{30}{1000} \text{ or } t = \frac{\sqrt{3}}{10}$$

$$u = \frac{150}{t} = \frac{150 \times 10}{\sqrt{3}} = 500\sqrt{3} \text{ ms}^{-1}$$

179 (a)

The radius of curvatures will be mutually perpendicular only when the velocity vectors will be mutually perpendicular, *i. e.*, after the time  $t = \sqrt{2} \frac{u}{g}$

180 (c)

As the speed with which the ball has been thrown in downward direction is greater than the terminal speed

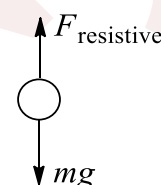

So,  $F_{\text{resistive}} > mg$

and hence initially net force acting on the ball is in upward direction and hence acceleration also is in the same direction

But this acceleration is opposite to velocity, so speed decreases and hence  $F_{\text{resistive}}$ . At a particular instant, the ball acquires the terminal speed and at this instant  $F_{\text{resistive}} = mg$  and hence  $a = 0$  and particle moves with constant speed, *i. e.*, the terminal speed

181 (c)

$$\text{Given } \frac{\sqrt{3}u}{2} = u \cos \theta = \text{speed at maximum height}$$

or

$$\cos \theta = \frac{\sqrt{3}}{2} \text{ or } \theta = 30^\circ \dots(i)$$

$$\text{Given that } PH_{\text{max}} = R \dots(ii)$$



We know  $H_{\max} = \frac{R \tan \theta}{4}$

$$P = \frac{R}{H_{\max}} = \frac{4}{\tan \theta} = \frac{4}{\tan 30^\circ} = 4\sqrt{3}$$

182 (b)

At the instant, when bolt starts falling it acquires the velocity of lift. Let it be  $v$

So, displacement of bolt w.r.t. ground is given by the equation,

$$y_{BG} = vt - \frac{1}{2}gt^2$$

Which is a parabolic equation but this is valid only for the time interval which it takes to the floor elevator

After that displacement-time graph of bolt and elevator would be same under the assumption that bolt sticks to the floor of elevator after striking it

183 (a)

$$\tan \theta = \frac{u \sin \theta}{u \cos \theta} = \frac{2}{1}$$

The desired equation is

$$y = x \tan \theta - \frac{gx^2}{2u^2 \cos^2 \theta}$$

$$= x \times 2 - \frac{10x^2}{2(\sqrt{2^2 + 1^2})^2 \left(\frac{1}{\sqrt{5}}\right)^2}$$

$$\text{or } y = 2x - 5x^2$$

184 (a)

$\vec{v}_m$  = Velocity of man

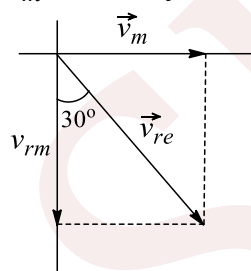

$\vec{v}_{re}$  = Velocity of rain w.r.t. earth

$\vec{v}_{rm}$  = Velocity of rain w.r.t. man

Velocity of man  $|\vec{v}_m| = 10 \text{ ms}^{-1}$

$$\text{Using } \sin 30^\circ = \frac{v_m}{v_{re}}$$

$$v_{re} = \frac{v_m}{\sin 30^\circ} = \frac{10}{1/2} = 20 \text{ ms}^{-1}, \cos 30^\circ = \frac{v_{rm}}{v_{re}}$$

$$v_{rm} = v_{re} \cos 30^\circ = \frac{20 \times \sqrt{3}}{2} = 10\sqrt{3} \text{ ms}^{-1}$$

185 (d)

The sum of these two angles is  $90^\circ$

186 (b)

$$h = (u \sin \theta)t - \frac{1}{2}gt^2$$

$$d = (u \cos \theta)t \text{ or } t = \frac{d}{u \cos \theta}$$

$$h = u \sin \theta \frac{d}{u \cos \theta} - \frac{1}{2}g \frac{d^2}{u^2 \cos^2 \theta}$$

$$u = \frac{d}{\cos \theta} \sqrt{\frac{g}{2(d \tan \theta - h)}}$$

187 (a,c)

(i) if  $\vec{A} = 3\hat{i} + 4\hat{j}$ , then  $|\vec{A}| = \sqrt{3^2 + 4^2} = 5$

(ii)  $W = (3\hat{i} + 4\hat{j}) \cdot 6\hat{j} = 24 \text{ J}$

(iii)  $|\vec{A} \times \vec{B}|$  = Area of parallelogram whose two adjacent sides are represented by two  $\vec{A}$  and  $\vec{B}$ .

(iv) component of force  $F$  in the direction making an angle  $\theta = F \cos \theta = 20 \cos 60^\circ = 20 \cdot \frac{1}{2} = 10 \text{ N}$

188 (b,c)

For  $\theta_A = 15^\circ$  and  $\theta_B = 75^\circ$ ,  $R_A = R_B$

$$U_A = U_B, \text{ But } \frac{h_A}{h_B} = \frac{u_A^2 \sin^2 \theta_A}{u_B^2 \sin^2 \theta_B} = \left(\frac{\sin 15^\circ}{\sin 75^\circ}\right)^2 < 1$$

or  $h_A < h_B$

$$\text{Again, } \frac{T_A}{T_B} = \frac{u_A \sin \theta_A}{u_B \sin \theta_B} = \frac{\sin 15^\circ}{\sin 75^\circ} < 1 \text{ or } T_A < T_B$$

189 (a,b)

$$T = \frac{2u \sin \theta}{g}, h = \frac{u^2 \sin^2 \theta}{2g}, R = \frac{u^2 \sin 2\theta}{g}$$

$$y = u \sin \theta t - \frac{1}{2}gt^2 = 4h \left[ \frac{u \sin \theta}{4h} - \frac{gt}{8h} \right]$$

$$= 4ht \left[ \frac{u \sin \theta}{4(u^2 \sin^2 \theta / 2g)} - \frac{gt}{8(u^2 \sin^2 \theta / 2g)} \right]$$

$$= 4ht \left[ \frac{1}{(2u \sin \theta / g)} - \frac{t}{(2u \sin \theta / g)^2} \right]$$

$$= 4ht \left[ \frac{1}{T} - \frac{1}{T^2} \right] = 4h \left( \frac{1}{T} \right) \left( 1 - \frac{t}{T} \right)$$

Now  $x = u \cos \theta t$ ,  $R = u \cos \theta T$

$$\Rightarrow \frac{t}{T} = \frac{x}{R}, \text{ so } y = 4h \left( \frac{x}{R} \right) \left( 1 - \frac{x}{R} \right)$$

190 (b)

When a particle moves along a circle with constant speed, it has centripetal acceleration  $a = v^2/r$ . Its direction is always towards the centre of the circle, which goes on varying. Therefore,  $a$  is variable. But KE of particle  $= \frac{1}{2}mv^2$ , which remains constant

191 (b,c,d)

Initially, the FBD of ball would be as shown in figure



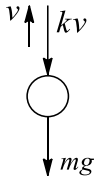

Here, directions of velocity and acceleration are opposite, so particle is slowing down and moving in upward direction. At one instant its velocity becomes zero, which would be the highest point of trajectory. Then it starts falling down, for its descent FBD would be as shown in figure

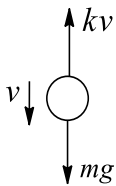

During its descent, the ball will acquire the terminal speed (assuming ball is not striking ground before acquiring the terminal speed) As work has been done against the resistive force, so speed of throwing is greater than speed with which the particle lands Hence, force of air friction is greatest (when speed is greatest) just after it is thrown

192 (a,c,d)

$(KE + PE)_f = (KE + PE)_i$  in all situations  
Hence,  $KE_f$  is also equal as  $PE_f = 0$ . Hence all the particles collide with the same speed  
 $-h = vt_1 - \frac{1}{2}gt_1^2$  [for first particle] ... (i)  
 $-h = -vt_2 - \frac{1}{2}gt_2^2$  [for second particle] ... (ii)  
From Eq. (i) and Eq. (ii)  $t_2 > t_1$   
 $t_2 = \text{maximum}, t_1 = \text{minimum}$   
i.e., options (c) and (d) are correct

193 (b,c)

$y = \frac{x}{2}$  implies that the particle is moving in a straight line passing through the origin

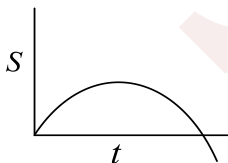

$$v_x = 4 - 2t, v_x = u_x + a_x t, u_x = 4, a_x = -2$$

$$\text{Now, } y = \frac{x}{2} \Rightarrow \frac{dy}{dt} = \frac{1}{2} \frac{dx}{dt}$$

$$v_y = \frac{1}{2} v_x = 2 - t, v_y = u_y + a_y t$$

$$u_y = 2 \text{ and } a_y = -1$$

194 (c,d)

In the given condition, the particle undergoes uniform circular motion and for uniform circular motion the velocity and acceleration vector changes continuously but kinetic energy is constant for every point

195 (a,c)

Vertical component of velocity of ball at point P  
 $v_V = 0 + gt = 10 \times 0.4 = 4 \text{ m/s}$   
Horizontal component of velocity = initial velocity  
 $\Rightarrow v_H = 4 \text{ m/s}$

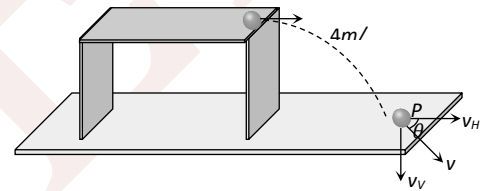

So the speed with which it hits the ground

$$v = \sqrt{v_H^2 + v_V^2} = 4\sqrt{2} \text{ m/s}$$

$$\text{and } \tan \theta = \frac{v_V}{v_H} = \frac{4}{4} = 1 \Rightarrow \theta = 45^\circ$$

It means the ball hits the ground at an angle of  $45^\circ$  to the horizontal

$$\text{Height of the table } h = \frac{1}{2}gt^2 = \frac{1}{2} \times 10 \times (0.4)^2 = 0.8 \text{ m}$$

$$\text{Horizontal distance travelled by the ball from the edge of table } h = ut = 4 \times 0.4 = 1.6 \text{ m}$$

196 (a,b)

$$\vec{v}_{AW} = -20\hat{j}$$

$$\vec{v}_{BW} = -32\hat{i} + 24\hat{j}$$

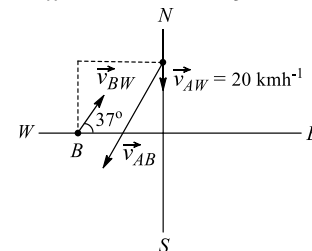

$$\vec{v}_{AB} = \vec{v}_{AW} - \vec{v}_{BW} = -32\hat{i} - 44\hat{j}$$

$$\frac{d\vec{r}_{AB}}{dt} = \vec{v}_{AB} = -32\hat{i} - 44\hat{j}$$



$$\int_{3\hat{i}+4\hat{j}}^{\vec{r}_{AB}} d(\vec{r}_{AB}) = - \int_a^t 32dt \hat{i} - \int_0^t 44 dt \hat{j}$$

$$\vec{r}_{AB} = (3 - 32t)\hat{i} + (4 - 44t)\hat{j}$$

At  $t = 1/11$  h,  $\hat{j}$  component of  $\vec{r}_{AB}$  is zero. At this time, its  $\hat{i}$  component is  $3 - 32t = 3 - \frac{32}{11} = \frac{1}{11}$  km

It means at  $t = \frac{1}{11}$ h, A will be east of B. So at no time, A will be west of B

197 (a,c,d)

Angular speed is constant. Hence, linear speed is also constant, i.e., magnitude of velocity is constant, but direction is changing

198 (b)

The vectors will be perpendicular, if  $\vec{A} \cdot \vec{B} = 0$

$$\therefore (2\hat{i} + 3\hat{j} + 4\hat{k}) \cdot (\hat{i} + 2\hat{j} - n\hat{k}) = 0$$

$$\text{or } 2 + 6 - 4n = 0 \text{ or } n = 2$$

199 (a,b,c,d)

$$v = 2t, a_c = \frac{v^2}{r} = \frac{(2t)^2}{0.2} = 20t^2 = 20 \times 2^2 = 80 \text{ ms}^{-2}$$

$$a_t = \frac{dv}{dt} = 2 \text{ ms}^{-2}$$

$$\text{Net acceleration } a = \sqrt{a_c^2 + a_t^2} > 80 \text{ ms}^{-2}$$

200 (b)

Average acceleration

$$\vec{a}_{av} = \frac{\vec{v}_f - \vec{v}_i}{t} = \frac{\vec{v}_f + (-\vec{v}_i)}{t} = \frac{\vec{v}}{t}$$

To find the resultant of  $\vec{v}_f$  and  $-\vec{v}_i$ , we draw the following figure

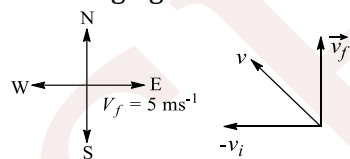

$$|\vec{v}| = \sqrt{v_f^2 + v_i^2} = \sqrt{5^2 + 5^2} = 5\sqrt{2} \text{ ms}^{-1}$$

$$\text{Since, } |\vec{v}_f| = |-\vec{v}_i|$$

$\vec{v}$  is directed in between  $\vec{v}_f$  and  $-\vec{v}_i$

Therefore,  $\vec{v}$  is directed towards N-W

$$\vec{a}_{av} = \frac{5\sqrt{2}}{10} = \frac{1}{\sqrt{2}}$$

201 (b,c,d)

If they collide, their vertical component of velocities should be same, i.e.

$$100 \sin \theta = 160 \sin 30^\circ \Rightarrow \sin \theta = 4/5$$

Their vertical components will always be same.

Horizontal components:

$$160 \cos 30^\circ = 80\sqrt{3} \text{ ms}^{-1}$$

$$\text{and } 100 \cos \theta = 100 \times 3/5 = 60 \text{ ms}^{-1}$$

They are not same, hence their velocities will not be same at any time. So (b) is correct

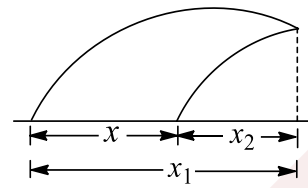

$$x = x_1 - x_2 = 160 \cos 30^\circ t - 100 \cos \theta t$$

$$\Rightarrow x = (80\sqrt{3} - 60)t$$

$$\text{Time of flight: } T = \frac{2 \times 160 \times \sin 30^\circ}{g} = 16 \text{ s (same for both)}$$

both)

Now  $t < T_x \rightarrow$  to collide in air

$$\Rightarrow \frac{x}{80\sqrt{3} - 60} < 16 \Rightarrow x < 1280\sqrt{3} - 960$$

Since their times of flight are same, they will simultaneously reach their maximum height. So it is possible to collide at the highest point for certain values of  $x$

202 (d)

In uniform circular motion,  $a_r = 0$ , but in non uniform circular motion,  $a_t \neq 0$ . In both cases,  $a_r \neq 0$

203 (b)

$$\text{Let } \vec{a} = a_x \hat{i} + a_y \hat{j} + a_z \hat{k} = \frac{dv_x}{dt} \hat{i} + \frac{dv_y}{dt} \hat{j} + \frac{dv_z}{dt} \hat{k}$$

As  $\vec{a}$  is constant, so its magnitude as well as direction is not changing, but  $v_x$ ,  $v_y$  and  $v_z$  all can be varying (any combination of these if  $a_x$ ,  $a_y$  or  $a_z = 0$ , then corresponding velocity component may be constant)

$$|\vec{v}| = v = \sqrt{v_x^2 + v_y^2 + v_z^2}$$

$$\frac{d|\vec{v}|}{dt} = \frac{1}{2\sqrt{v_x^2 + v_y^2 + v_z^2}}$$

$$\times \left[ 2v_x \frac{dv_x}{dt} + 2v_y \frac{dv_y}{dt} + 2v_z \frac{dv_z}{dt} \right] = \frac{\vec{v} \cdot \vec{a}}{v}$$

Which is a variable quantity

$$\left| \frac{d\vec{v}}{dt} \right| = |\vec{a}|, \text{ which would be constant}$$

$$\frac{dv^2}{dt} = \frac{d(v_x^2 + v_y^2 + v_z^2)}{dt} = 2\vec{v} \cdot \vec{a} \text{ (a variable quantity)}$$



$$\frac{d(\vec{v}/v)}{dt} = \frac{d}{dt} \left[ \frac{v_x \hat{i} + v_y \hat{j} + v_z \hat{k}}{\sqrt{v_x^2 + v_y^2 + v_z^2}} \right] \text{ (a variable quantity)}$$

204 (b)

$$\begin{aligned} |\text{Average velocity}| &= \frac{|\text{Displacement}|}{\text{Time}} \\ &= \frac{2r}{t} = 2 \times \frac{1}{1} = 2 \text{ ms}^{-1} \end{aligned}$$

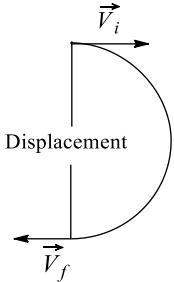

205 (a,b)

$$x = a \cos(pt), y = b \sin(pt)$$

Equation of path in  $x - y$  plane is  $\left[\frac{x}{a}\right]^2 + \left[\frac{y}{b}\right]^2 = 1$   
i.e., the path of the particle is an ellipse

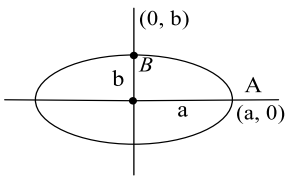

Position vector of a point  $P$  is

$$\vec{r} = a \cos pt \hat{i} + b \sin pt \hat{j}$$

$$\Rightarrow \vec{v} = p(-a \sin pt \hat{i} + b \cos pt \hat{j})$$

$$\text{and } \vec{a} = -p^2(-a \cos pt \hat{i} + b \sin pt \hat{j}) = -p^2 \vec{r}$$

Acceleration directed towards the centre

$$\text{Also, } \vec{v} \cdot \vec{a} = 0 \text{ at } t = \pi/2p,$$

$$\text{At } t = 0, \vec{r} = a \hat{i}$$

$$\text{At } t = \pi/2p, \vec{r} = b \hat{j}$$

So in time  $t = 0$  to  $t = \pi/2p$ , particle goes from  $A$  to  $B$  travelling a distance more than  $a$

206 (b,c)

$$|\vec{F}| = \sqrt{(1)^2 + (1)^2 + (\sqrt{2})^2} = 2$$

If  $\theta$  is the angle of  $\vec{F}$  with  $z$ -axis, then

$$\cos \theta = \frac{\vec{F} \cdot \hat{k}}{F} = \frac{\sqrt{2}}{2} = \frac{1}{\sqrt{2}} = 45^\circ$$

$$\theta = 45^\circ$$

207 (a,d)

$\alpha$  cannot remain positive for all  $t$  in the interval  $0 \leq t \leq 1$ . This is because since the body starts from rest, it will first accelerate, finally it stops therefore  $a$  will become negative. Therefore,  $a$

will change its direction. Hence, (a) and (d) are the correct options

208 (b,c,d)

Based on thought

209 (a,d)

$$|\vec{A} \times \vec{B}| = 15 = AB \sin \theta = 5 \times 6 \sin \theta$$

$$\text{or } \sin \theta = \frac{15}{30} = \frac{1}{2} \sin 30^\circ \text{ or } \sin 150^\circ$$

$$\text{or } \theta = 30^\circ \text{ or } 150^\circ$$

210 (b,d)

A body moving on a circular path with uniform speed must have varying velocity as well as acceleration

211 (a,d)

$$\vec{v}_r = -30\hat{j}, \vec{v}_m = \frac{10\sqrt{3}}{2}\hat{i} + \frac{10}{2}\hat{j}$$

$$\tan \theta = \frac{5\sqrt{3}}{35} = \frac{\sqrt{3}}{7} \Rightarrow \theta = \tan^{-1}\left(\frac{\sqrt{3}}{7}\right) \text{ with vertical}$$

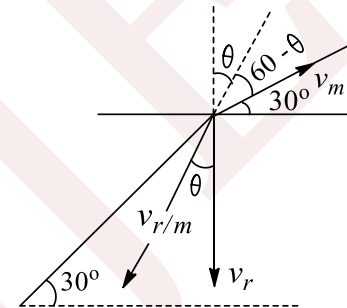

Angle of  $v_{r/m}$  with inclined plane is  $60 - \theta = \beta$

$$\tan \beta = \tan(60 - \theta) = \frac{\tan 60^\circ - \tan \theta}{1 + \tan 60^\circ \cdot \tan \theta}$$

$$= \frac{\sqrt{3} - \sqrt{3}/7}{1 + \sqrt{3} \cdot \sqrt{3}/7} = \frac{3\sqrt{3}}{5}$$

$$\Rightarrow \beta = \tan^{-1}\left(\frac{3\sqrt{3}}{5}\right)$$

212 (a,c)

For angle  $\theta$  in west of north

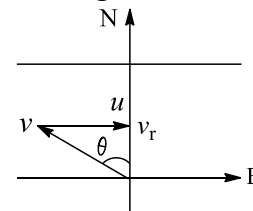

$$\sin \theta = \frac{5}{10} = 0.5, \text{ i.e., } \theta = 30^\circ$$

$$V_t = \text{resultant velocity} = \sqrt{(10)^2 - (5)^2} = 5\sqrt{3} \text{ ms}^{-1}$$

So, options (a) and (c) are correct

213 (a,b,c)

This is the example of non-uniform acceleration



$$a = \frac{dv}{dt} = -0.5t$$

$$\int_{16}^v dv = - \int_0^t 0.5t dt \Rightarrow v = 16 - \frac{0.5t^2}{2}$$

Direction of velocity changes at the moment when it becomes zero momentarily

$$0 = 16 - \frac{0.5t^2}{2} \Rightarrow t = 8 \text{ s}$$

$$\frac{dx}{dt} = v = 16 - \frac{0.5t}{2}$$

Let us consider that at  $t = 0$ , particle is at  $x = 0$

$$\int_0^x dx = \int_0^t \left(16 - \frac{0.5t^2}{2}\right); x = 16t - \frac{0.5t^3}{6};$$

Distance travelled = |displacement| for  $t \leq 8$  s. So, distance travelled in 4 s

$$x = 16 \times 4 - \frac{0.5 \times 4^3}{6} \approx 59 \text{ m}$$

Distance travelled in 10 s = |displacement in 8 s|  $\times 2$  - Displacement in 10 s =  $85.33 \times 2 - 76.55 = 94 \text{ m}$

$$v(t = 10 \text{ s}) = -9 \text{ ms}^{-1}$$

214 (b,c)

Initially, accelerations are opposite to velocities, hence motion will be retarded. But after sometimes velocity will be retarded. But after sometimes velocity will become zero and then velocity will in the direction of acceleration. Now the motion will be acceleration. As the particle is blown over by a wind with constant velocity along horizontal direction, the particle has a horizontal component of velocity. Let this component be  $v_0$ . Then it may be assumed that the particle is projected horizontally from the top of the tower with velocity  $v_0$

Hence, for the particle, initial velocity  $u = v_0$  and angle of projection  $\theta = 0^\circ$

We know equation of trajectory is

$$y = x \tan \theta - \frac{gx^2}{2u^2 \cos^2 \theta}$$

$$\text{Here, } y = -\frac{gx^2}{2v_0^2} (\text{putting } \theta = 0^\circ)$$

The slope of the trajectory of the particle is

$$\frac{dy}{dx} = -\frac{2gx}{2v_0^2} = -\frac{g}{v_0^2}x$$

Hence, the curve between slope and  $x$  will be a straight line passing through the origin and will

have a negative slope. It means that option (b) is correct

Since horizontal velocity of the particle remains constant,  $x = v_0 t$ . We get  $\frac{dy}{dx} = -\frac{gt}{v_0}$

So the graph between  $m$  and time  $t$  will have the same shape as the graph between  $m$  and  $x$ . Hence, option (a) is wrong

The vertical component of velocity of the particle at time  $t$  is equal to  $gt$ . Hence, at time  $t$

$$\text{KE} = \frac{1}{2}m[(gt)^2 + (v_0)^2]$$

It means, the graph between KE and time  $t$  should be a parabola having value  $\frac{1}{2}mv_0^2$  at  $t = 0$ .

Therefore, option (c) is correct

As the particle falls, its height decreases and KE increases

$\text{KE} = \frac{1}{2}mv_0^2 + mg(H - h)$ , where  $H$  is the initial height. The KE increases linearly with height of its fall or the graph between KE and height of the particle will be a straight line having negative slope. Hence, option (d) is wrong

215 (d)

$$\text{Here, } \vec{A} \cdot \vec{B} = (5\hat{i} + 6\hat{j} + 3\hat{k}) \cdot (6\hat{i} - 2\hat{j} - 6\hat{k}) = 0$$

So  $\vec{A}$  is perpendicular to  $\vec{B}$  and  $\vec{A}$  is not equal to  $\vec{A} \times \vec{B}$ , as cross product of two vectors in anticommunicative. The magnitude of  $\vec{A}$  is  $\sqrt{70}$  and of  $\vec{B}$  is  $\sqrt{76}$ .

216 (b,c,d)

If the particle is projected with velocity  $u$  at an angle  $\theta$ , then equation of its trajectory will be

$$y = x \tan \theta - \frac{gx^2}{2u^2 \cos^2 \theta}$$

We know slope is given by  $m = \frac{dy}{dx} = \frac{gx}{u^2 \cos^2 \theta}$

Therefore, slope  $m = \tan \theta - \frac{gx}{u^2 \cos^2 \theta}$

It implies that the graph between slope and  $x$  will be straight line having negative slope and a non-zero positive intercept on  $y$ -axis

But  $x$  is directly proportional to the time  $t$ ; therefore, the shape of graph between slope and time will be same as that of the graph between slope and  $x$ . Hence, only option (a) is correct, i.e., options (b),(c) and (d) are incorrect

217 (a,d)



With respect to observer  $A$  on the train, the ball has velocity  $\vec{u}$  along one direction only. Hence the motion of ball w.r.t. observer  $A$  is at straight line. With respect to observer  $B$ , the ball has two velocities which are inclined at angle  $\theta$ . Due to which the path followed by ball w.r.t. observer  $B$  is parabolic.

218 (a,c,d)

Total displacement ball  $A$  in 2 s,

$$S = ut - \frac{1}{2}gt^2 = 10 \times 2 - \frac{1}{2} \times 10 \times (2)^2 = 0$$

Hence, both  $A$  and  $B$  will reach the ground simultaneously and strike with the same velocity

219 (a,c,d)

$$u_x = u_y = 0, a_x = 4.9 \text{ ms}^{-2}, a_y = 9.8 \text{ ms}^{-2}$$

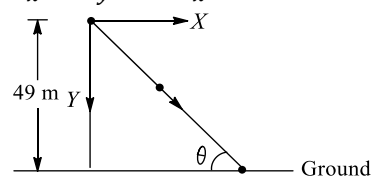

$$\text{So } x = \frac{1}{2}a_x t^2, \text{ and } y = \frac{1}{2}a_y t^2$$

$$\frac{x}{y} = \frac{a_x}{a_y} = \frac{1}{2}$$

So path of the ball is a straight line

Let  $t$  be the time taken by the ball to reach ground,

$$\tan \theta = \frac{a_y}{a_x} = 2 \Rightarrow \theta = \tan^{-1}(2)$$

220 (b,c)

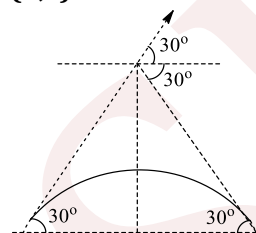

$$T = \frac{2u \sin \theta}{g} = \frac{2 \times 10 \times \frac{1}{2}}{10} = 1 \text{ s}$$

221 (a,c,d)

Velocity is given by the slope of the  $x-t$  graph.

Here the slope is zero at  $A$  and at peak of region  $CD$  and bottom most point of  $EF$

For  $AB$  and  $EF$ , acceleration is positive. For these regions, graph is concave up

For  $BC$  and  $DE$ , acceleration is zero as here velocity is constant

For  $CD$ , acceleration is negative as graph is concave down for this region

222 (b,d)

At initial point  $v_x = v \cos \theta$  and  $v_y = v \sin \theta$ . At second point, where particle moves at right angle to its direction, let its velocity be  $v'$ . Then  $v'_x = v \sin \theta = v_x = v \cos \theta$

$$\Rightarrow v' \frac{\cos \theta}{\sin \theta} = v \cot \theta$$

$$\text{Since } v'_y - gt \text{ or } t = \frac{v_y - v'_y}{g}$$

$$\begin{aligned} \therefore t &= \frac{v \sin \theta = v' \cos \theta}{g} \\ &= \frac{v \sin \theta - v \cot \theta \cdot \cos \theta}{g} \\ &= \frac{v \sin \theta}{g} (1 - \cot \theta) = \frac{v}{g \sin \theta} \end{aligned}$$

223 (c)

$$\text{Horizontal range } R = \frac{u^2 \sin 2\theta}{g} = \frac{u^2 \sin 2 \times 45^\circ}{g} = \frac{u^2}{g}$$

$$\begin{aligned} \text{Maximum height} &= \frac{u^2 \sin^2 \theta}{2g} \\ &= \frac{u^2 \sin^2 45^\circ}{2g} = \frac{u^2}{2g} \left(\frac{1}{\sqrt{2}}\right)^2 = \frac{u^2}{4g} \end{aligned}$$

$$R : h = 4 : 1$$

224 (c)

Centripetal force always acts perpendicular to the instantaneous displacement of the body on circular path so,  $\theta = 90^\circ$  and  $W = Fs \cos 90^\circ = 0$

225 (a,b)

$$\text{Time of ascent} = 2 + 1 = 3 \text{ s}$$

$$\Rightarrow \frac{u \sin \theta}{g} = 3 \Rightarrow u \sin \theta = 30$$

$$\begin{aligned} \text{And } \tan \beta &= \frac{u \sin \theta - gt}{u \cos \theta} \Rightarrow \tan 30^\circ = \frac{30 - 10 \times 2}{u \cos \theta} \\ \Rightarrow u \cos \theta &= 10\sqrt{3} \end{aligned}$$

$$\text{From here } u = \sqrt{(10\sqrt{3})^2 + 10^2} = 20\sqrt{3} \text{ ms}^{-1}$$

$$\text{and } \tan \theta = \frac{30}{10\sqrt{3}} = \sqrt{3} \Rightarrow \theta = 60^\circ$$

226 (b)

$$\text{Net velocity of boat in river} = \sqrt{5^2 - u^2}$$

$$t = \frac{\text{Distance}}{\text{Velocity}} \Rightarrow \frac{1}{4} = \frac{1}{\sqrt{5^2 - u^2}} \Rightarrow u = 3 \text{ kmh}^{-1}$$

227 (b,c,d)

The two particles will collide after time  $t$  if the distance moved along  $x$ -axis of  $A$  is equal to that



of  $B$  and the distance moved along  $y$ -axis of  $A$  is equal to that of  $B$

$$\text{So, } u_1 t = \frac{1}{2} a_2 t^2$$

$$\text{and } u_2 t = \frac{1}{2} a_1 t^2$$

$$\therefore \frac{u_1}{u_2} = \frac{a_2}{a_1} \text{ or } u_1 a_1 = u_2 a_2$$

The particles will have the same speed at some point after time  $t$  if

$$\sqrt{u_1^2 + (a_1 t)^2} = \sqrt{u_2^2 + (a_2 t)^2}$$

$$\text{or } u_1^2 - u_2^2 = (a_2^2 - a_1^2) t^2$$

$$\text{or } t = \sqrt{\frac{u_1^2 - u_2^2}{a_2^2 - a_1^2}} t \text{ will be positive if } u_1 > u_2 \text{ and}$$

$$a_2 > a_1$$

228 (a)

$$\text{Centripetal acceleration } a_c = v^2/r = v\omega$$

When  $v$  is doubled,  $\omega$  is halved. ( $v\omega$ ) shall remain unchanged

229 (c,d)

Distance between two buses on road is  $V_b T$

For  $A$  to  $B$  direction

distance = relative velocity  $\times$  time,

$$V_b T = (V_b - V_c) T_1 \Rightarrow T_1 = \frac{V_b T}{V_b - V_c}$$

For  $B$  to  $A$  direction:

$$V_b T = (V_b + V_c) T_2 \Rightarrow T_2 = \frac{V_b T}{V_b + V_c}$$

230 (a)

$$\text{Time taken to cross the river } t = \frac{d}{v_s \cos \theta}$$

For time to be minimum,  $\cos \theta = \max \Rightarrow \theta = 0^\circ$

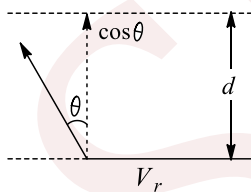

Hence, the swimmer should swim due north

231 (b,c,d)

Point of steepest slope corresponds to the maximum speed. Particle will speed up when the directions of acceleration and velocity are same.

For region  $AB$ , both the acceleration and velocity are positive while for  $CD$  both are negative, so particle is speeding up in these regions

232 (a,c)

$$\frac{dx}{dt} = t^2 \dots(i), y = \frac{1}{2} t^3 \Rightarrow \frac{dy}{dt} = \frac{t^2}{2} \dots(ii)$$

$$t = 1, v_x = 1, v_y = \frac{1}{2} \Rightarrow \vec{v} = \hat{i} + \frac{1}{2} \hat{j}$$

$$\frac{d^2x}{dt^2} = 2t \quad \text{(iii)} \quad \frac{d^2y}{dt^2} = t \quad \text{(iv)}$$

$$\text{At } t = 1 \text{ s, } a_x = 2 \text{ and } a_y = 1 \Rightarrow \vec{a} = 2\hat{i} + \hat{j}$$

233 (a,b,d)

As the particle is going up, it is slowing down, i.e., speed is decreasing and hence we can say that time taken by the particle to cover equal distance is increasing as the particle is going up

Hence,  $t_1 < t_2 < t_3$

As  $v_{av} = \frac{\text{Distance}}{\text{Time}}$ , we have  $v_{av} \propto \frac{1}{\text{Time}}$

$$\text{So, } v_{av_1} > v_{av_2} > v_{av_3}$$

Acceleration throughout the motion remains same from equation,

$$\vec{v} = \vec{u} + \vec{a}t, \Delta v \propto t \text{ So } \Delta v_1 < \Delta v_2 < \Delta v_3$$

234 (d)

As  $\omega = \frac{2\pi}{T} = \text{constant}$ , therefore,  $v \propto r$ . Also,  $\omega$

does not depend on  $r$

235 (a)

Before hitting the ground, the velocity  $v$  is given by  $v^2 = 2gd$  (quadratic equation and hence parabolic path)

Downward direction means negative velocity.

After collision, the direction become positive and velocity decreases

$$\text{Further, } v^2 = 2g \times \left(\frac{d}{2}\right) = gd; \left(\frac{v}{v'''}\right) = \sqrt{2}$$

$$\text{Or } v = v' \sqrt{2}$$

As the direction is reversed and speed is decreased and hence graph (a) represents these conditions correctly

236 (b,c)

$$v = \frac{dx}{dt} = -9 + t^2 = 0 \Rightarrow t = 3 \text{ s}$$

The particle's velocity is getting zero at  $t = 3 \text{ s}$ , where it changes its direction of motion

For  $0 < t < 3 \text{ s}$ ,  $v$  is negative,  $a$  is positive, so particle is slowing down

For  $t > 3$ , both  $v$  and  $a$  are positive, so the particle is speeding up

237 (a,c,d)

Self-explanatory

238 (a)

Time taken is shortest when one aims perpendicular to the flow



239 (a)

The body is able to move in a circular path due to centripetal force. The centripetal force in case of vehicle is provided by frictional force. Thus if the value of frictional force  $\mu mg$  is less than centripetal force, then it is not possible for a vehicle to take a turn and the body would overturn

Thus condition for safe turning of vehicle is,

$$\mu mg \geq \frac{mv^2}{r}$$

240 (d)

At the highest point, only the horizontal component of velocity is present and the vertical component is zero

241 (a)

$$\cos\theta = \frac{(\hat{i}+\hat{j})\cdot\hat{i}}{|\hat{i}+\hat{j}||\hat{i}|} = \frac{1}{\sqrt{2}} = \cos 45^\circ$$

$$\text{so, } \theta = 45^\circ$$

242 (c)

Due to air resistance, the accelerations of both balls will be different. Hence, they will reach at different times and with different velocities

243 (a)

When roads are not properly banked force of friction between tyres and road provides partially the necessary centripetal force. This causes wear and tear

244 (d)

For uniformly accelerated motion started from rest, the displacement versus time graph is parabolic

And for uniformly accelerated motion the velocity in equal intervals of time changes by same amount

245 (a)

$$\text{Horizontal range} = \frac{u^2 \sin^2 \theta}{g}$$

$$= \frac{(2\sqrt{gh})^2 \sin^2 60^\circ}{g} = 2\sqrt{3}h$$

246 (a)

When roads are not properly banked, force of friction between tyres and road provides partially the necessary centripetal force. This causes wear and tear of tyres

247 (c)

Alloys have least variation in length with temperature

248 (d)

Projectile motion is a motion with constant acceleration but it is not a straight line motion

A body with constant magnitude of acceleration may not speed up, this is possible in uniform circular motion

249 (d)

The direction of velocity vector is always along the tangent to the path but its slope will not give the magnitude of velocity. Magnitude of velocity is given by the slope of position-time graph

250 (c)

Centripetal force is defined from formula

$$F = \frac{mv^2}{r} \Rightarrow F \propto \frac{v^2}{r}$$

If  $v$  and  $r$  both are doubled then  $F$  also gets doubled

251 (c)

Here assertion is correct but reason is wrong; because in circular motion the direction of centripetal force is perpendicular to the velocity

252 (d)

Here assertion is false and reason is true.

253 (a)

For second's hand,  $T = 60$  s

$$\therefore \omega = \frac{2\pi}{T} = \frac{2\pi}{60} = \frac{\pi}{30} \text{ rad s}^{-1}$$

254 (a)



$$OA = OC$$

$\vec{OC} + \vec{OC}$  is along  $\vec{OB}$  (bisector) and its magnitude is

$$2R \cos 45^\circ = R\sqrt{2}$$

$(\vec{OC} + \vec{OC}) + \vec{OB}$  is along  $\vec{OB}$  and its magnitude is

$$R\sqrt{2} + R = R(1 + \sqrt{2})$$

255 (c)

$$R = \frac{u^2 \sin 2\theta}{g} \therefore R_{\max} = \frac{u^2}{g} \text{ when } \theta = 45^\circ \therefore R_{\max} \propto u^2$$

$$\text{Height } H = \frac{u^2 \sin^2 \theta}{2g} \Rightarrow H_{\max} = \frac{u^2}{2g}$$

When  $\theta = 90^\circ$

$$\text{It is clear that } H_{\max} = \frac{R_{\max}}{2}$$

256 (b)

In a non-uniform circular motion, due to change in magnitude of velocity, tangential acceleration arises and due to change in direction of velocity, centripetal acceleration is produced

257 (d)

Least count depends upon the scale

258 (a)

Let  $\mu$  be the coefficient of static friction between the tyres and the road, the magnitude of friction force  $F$  will not exceed  $\mu mg$ , so that  $F' \leq \mu mg$

$$\text{Hence, for a safe turn } \frac{mv^2}{r} \leq \mu mg$$

$$\text{or } \mu \geq \frac{v^2}{rg} \text{ or } v \leq \sqrt{\mu rg}$$

Hence, when speed of car (automobile) exceeds the value of  $\sqrt{\mu rg}$  then it overturns, as the inner wheels are moving in a circle of smaller radius, the maximum possible velocity is less for it. Therefore, the wheels leave the ground first and car will overturn on the outside

259 (b)

Speed and velocity are different physical quantities. Speed is a scalar quantity and velocity is vector

260 (a)

$$\vec{A} = \frac{1}{\sqrt{3}}\hat{i} + \frac{1}{\sqrt{3}}\hat{j} + \frac{1}{\sqrt{3}}\hat{k}$$

$$A = \left[ \left(\frac{1}{\sqrt{3}}\right)^2 + \left(\left(\frac{1}{\sqrt{3}}\right)^2 + \left(\frac{1}{\sqrt{3}}\right)^2\right) \right]^{1/2} = 1$$

261 (a)

If  $v - t$  graph is perpendicular to time axis, its slope will be infinite, which will indicate infinite acceleration, which is not possible in practice

262 (b)

If we cut the string anywhere, the bob will follow a parabolic path

263 (d)

Within a certain speed of the turn table the frictional force between the coin and the turn table supplies the necessary centripetal force required for circular motion. On further increase of speed, the frictional force cannot supply the necessary centripetal force. Therefore the coin files off tangentially

264 (d)

In assertion, the direction of  $(\vec{A} \times \vec{B})$  according to Right Hand Rule is towards West. Thus assertion is false and reason is true.

265 (a)

Backlash error is caused due to wear and tear or loose fittings in screws and can be minimized by turning the screw in one direction only

266 (b)

On an unbanked road, friction provides the necessary centripetal force  $\frac{mv^2}{r} = \mu mg \therefore v = \sqrt{\mu rg}$



Thus with increase in friction, safe velocity limit also increases

When the road is banked with angle of  $\theta$  than its limiting velocity is given by

$$v = \sqrt{\frac{rg(\tan \theta + \mu)}{1 - \mu \tan \theta}}$$

Thus limiting velocity increase with banking of road

267 (e)

At the highest point, vertical component of velocity becomes zero so there will be only horizontal velocity and it is perpendicular to the acceleration due to gravity

268 (d)

While moving along a circle, the body has a constant tendency to regain its natural straight path

This tendency gives rise to a force called centrifugal force. The centrifugal force does not act on the body in motion, the only force acting on the body in motion is centripetal force. The centrifugal force acts on the source of centripetal force to displace it radially outward from the centre of the path

269 (d)

$$y = x \tan \theta - \frac{gx^2}{2u^2 \cos^2 \theta}$$

270 (c)

Cross product of vectors is anticommutative. Therefore,  $\vec{v} = \vec{\omega} \times \vec{r} = -\vec{r} \times \vec{\omega}$ . Choice (c) is correct

271 (b)

Before attaining the maximum height, angle is acute and after this the angle is obtuse. At the highest point, it is perpendicular

272 (c)

In circular motion the frictional force acting towards the centre of the horizontal circular path provides the centripetal force and avoid

overturning of vehicle. Due to the change in direction of motion, velocity changes in circular motion

273 (c)

$$T \propto u \text{ and } R \propto u^2$$

When velocity of projection of a body is made  $n$  times, then its time of flight becomes  $n$  times and range becomes  $n^2$  times

274 (a)

Since relative acceleration is zero and initial relative velocity is also zero, relative velocity at any moment will be zero

275 (c)

$$\text{For safe turn } \tan \theta \geq \frac{v^2}{rg}$$

It is clear that for safe turn  $v$  should be small and  $r$  should be large. Also banking angle from the vertical would increase in velocity

276 (e)

The man should point his rifle at a point higher than the target since the bullet suffers a vertically downward deflection ( $y = \frac{1}{2}gt^2$ ) due to gravity

277 (e)

Due to earth's axial rotation, the speed of the trains relative to earth will be different and hence the centripetal forces on them will be different.

Thus their effective weights  $mg - \frac{mv^2}{r}$  and  $mg + \frac{mv^2}{r}$  will be different. So they exert different pressure on the rails

278 (b)

When automobile moves in circular path then reaction on inner wheel and outer wheel will be different

$$R_{\text{inner}} = \frac{M}{2} \left[ g - \frac{v^2 h}{ra} \right] \text{ and } R_{\text{outer}} = \frac{M}{2} \left[ g + \frac{v^2 h}{ra} \right]$$

$$\text{In critical condition } v_{\text{safe}} = \sqrt{\frac{gra}{h}}$$



If  $v$  is equal or more than the critical value then reaction on inner wheel becomes zero. So it leaves the ground first

279 (c)

In a uniform circular motion, velocity is along tangential direction and acceleration is always towards centre, so angle between velocity vector and acceleration vector is always  $\pi/2$ . But in general, angle between velocity and the acceleration can be acute or obtuse also

280 (a)

$H = \frac{u^2 \sin^2 \theta}{2g}$  i. e. it is independent of mass of projectile

281 (c)

Slope of position-time graph will give the velocity and from here we can find both direction and magnitude of acceleration

282 (d)

When velocity at the lowest point is  $\sqrt{5gr}$ , velocity at highest point =  $\sqrt{gr} \neq 0$ . That is why, the vertical loop is completed

283 (a)

Let  $t$  be the time taken by the projectile while going through height  $h$ . Taking vertical upward motion of projectile, we have

$$y_0 = 0, y = h, u_y = 2\sqrt{gh} \sin 60^\circ$$

$$= 2\sqrt{gh} \times \frac{\sqrt{3}}{2} = \sqrt{3gh}$$

$$a_y = -g, t = ?$$

$$\text{As, } y = y_0 + u_y t + \frac{1}{2} a_y t^2$$

$$\therefore h = 0 + \sqrt{3gh}t + \frac{1}{2}(-g)t^2$$

$$\text{or } gt^2 - 2\sqrt{3gh}t + 2h = 0$$

On solving, we get two value of time,

$$\text{i.e., } \left( \frac{\sqrt{3gh} + \sqrt{gh}}{g} \right)$$

and  $\left( \frac{\sqrt{3gh} - \sqrt{gh}}{g} \right)$ , Here, the first time is to reach a height  $h$  while going up and second time is to come back at height  $h$ . Therefore, time of projectile above the height  $h$  is

$$= \left( \frac{\sqrt{3gh} + \sqrt{gh}}{g} \right) - \left( \frac{\sqrt{3gh} - \sqrt{gh}}{g} \right)$$

$$= \frac{2\sqrt{gh}}{g} = \sqrt{\frac{4h}{g}}$$

284 (c)

$$v_r/m = \sqrt{v_r^2 + v_m^2}$$

285 (a)

$$\text{Maximum height} = \frac{u^2 \sin^2 \theta}{2g}$$

$$= \frac{(2\sqrt{gh})^2 \sin^2 60^\circ}{2g} = \frac{4gh \times 3/4}{2g} = \frac{3h}{2}$$

286 (c)

Least count = pitch/number of circular scale divisions. Less is the pitch, less is least count so more is the accuracy

287 (a)

Both bodies will take same time to reach the earth because vertical downward component of the velocity for both the bodies will be zero and time of descent =  $\sqrt{\frac{2h}{g}}$ . Horizontal velocity has no effect on the vertical direction

288 (c)

$$T = \frac{2u \sin \theta}{g} \Rightarrow T \propto u, R = \frac{u^2 \sin 2\theta}{g} \Rightarrow R \propto u^2$$

289 (c)

$$\tan \theta = \frac{v^2}{rg}$$

When  $v$  is large and  $r$  is small  $\tan \theta$  increases. Therefore  $\theta$  increases, chances of skidding increase. Choice (c) is correct

290 (c)



Time of flight,  $T = \frac{2u_y}{g}$

or  $u_y = \frac{gT}{2} = \frac{10 \times 6}{2} = 30 \text{ ms}^{-1}$

Vertical velocity after 2s,  $v_y = u_y - gt$   
 $= 30 - 10 \times 2 = 10 \text{ ms}^{-1}$

Horizontal velocity after 2 s,  $v_x = u_x$

As per question,  $\tan 30^\circ = \frac{v_y}{v_x} = \frac{10}{u_x}$

or  $u_x = \frac{10}{\tan 30^\circ} = 10\sqrt{3} \text{ ms}^{-1}$

$\therefore u = \sqrt{u_x^2 + u_y^2} = \sqrt{(10\sqrt{3})^2 + (30)^2}$

$= 20\sqrt{3} \text{ ms}^{-1}$

291 (a)

Range,  $R = \frac{u^2 \sin 2\theta}{g}$

When  $\theta = 45^\circ$ ,  $R_{\max} = \frac{u^2}{g} \sin 90^\circ = \frac{u^2}{g}$

When  $\theta = 135^\circ$ ,  $R_{\max} = \frac{u^2}{g} \sin 270^\circ = \frac{-u^2}{g}$

Negative sign shows opposite direction

292 (d)

$\tan \theta = \frac{u_y}{u_x} = \frac{30}{10\sqrt{3}} = \sqrt{3} = \tan 60^\circ$

$\therefore \theta = 60^\circ$

293 (a)

From relation

$F = \frac{mv^2}{r} = \frac{m(r\omega)^2}{r} = mr\omega^2$

$= mr(2\pi v)^2 = 4\pi^2 mrv^2$

Here,  $m = 1 \text{ kg}$ ,  $v = 1 \text{ rps}$ ,  $r = 1 \text{ m}$

$\therefore F = 4\pi^2 \times 1 \times 1 \times 1^2 = 4\pi^2 \text{ N}$

294 (c)

i  $\rightarrow$  a. Range is maximum, when the angle of projection is  $45^\circ$

$H = \frac{v^2}{2g} \sin^2 45 = \frac{v^2}{4g} \dots(i)$

Velocity, at half of the maximum height is  $v$

$v'^2 = v^2 \sin^2 45 - 2g \frac{H}{2} = \frac{v^2}{2} - \frac{v^2}{4} \Rightarrow v' = \frac{\sqrt{3}v}{2}$

ii  $\rightarrow$  b. Velocity at the maximum height

$v' = v \cos 45 \Rightarrow v' = \frac{v}{\sqrt{2}}$

[Because vertical component of velocity is zero at the highest point]

iii  $\rightarrow$  c. Projection velocity

At projection point,  $v_i = v \cos 45 \hat{i} + v \sin 45 \hat{j}$

At the point, when the body strikes the ground

$\vec{v}_f = v \cos 45 \hat{i} - v \sin 45 \hat{j}$

$\Delta v = \vec{v}_f + (-\vec{v}_i) = 2 v \sin 45 (-\hat{j})$

$|\Delta \vec{v}| = 2 v \sin 45 = v\sqrt{2}$

iv  $\rightarrow$  d. Average velocity =  $\frac{\text{Total displacement}}{\text{Total time}}$

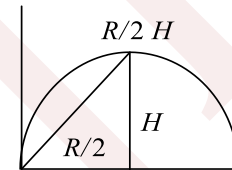

Displacement =  $\sqrt{\left(\frac{R}{2}\right)^2 + H^2}$

$\vec{v}_{av} = \frac{\sqrt{\frac{R^2}{4} + H^2}}{\frac{v \sin \theta}{g}} = \frac{\sqrt{R^2 + 4H^2}}{2v \sin \theta}$

$v_{av} = \frac{\sqrt{\left(\frac{v^2}{g}\right)^2 + 4\left(\frac{v^2}{4g}\right)^2}}{\frac{\sqrt{2}v}{g}}$

$= \frac{\frac{v^2}{g} \sqrt{1 + \frac{1}{4}}}{\frac{v\sqrt{2}}{g}} = \frac{v^2 \sqrt{5}}{2v\sqrt{2}} = \frac{v}{2} \sqrt{\frac{5}{2}}$

295 (d)

$y = Px - Qx^2$

Equation of trajectory of projectile motion is given by

$y = x \tan \theta - \frac{gx^2}{2u^2 \cos^2 \theta}$

On comparing,  $\tan \theta = P$

So iv  $\rightarrow$  b



$$\frac{g}{2u^2 \cos^2 \theta} = Q; u \cos \theta = \sqrt{\frac{g}{2Q}}$$

$$\begin{aligned} \text{Range } R &= \frac{2u^2}{g} \sin \theta \cos \theta = \frac{2u^2 \cos^2 \theta}{g} \tan \theta \\ &= \frac{2}{g} \frac{g}{2Q} P = \frac{P}{Q} \end{aligned}$$

So i → a

$$\begin{aligned} \text{Maximum height } H &= \frac{u^2}{2g} \sin^2 \theta \\ &= \frac{1}{2g} \frac{g}{2Q} \frac{\sin^2 \theta}{\cos^2 \theta} = \frac{1}{2Q} P^2 = \frac{P^2}{4Q^2} \end{aligned}$$

So ii. → c

$$\text{Time of flight } T = \frac{2u \sin \theta}{g} = \frac{2}{g} \sqrt{\frac{g}{2Q}} P = \sqrt{\frac{2}{Qg}} P$$

296 (a)

Here, maximum height for all the particles is same

$$H = \frac{u^2 \sin^2 \theta}{2g} = \frac{u_y^2}{2g}$$

So, all three particles have same  $u_y$

$$T = \frac{2u \sin \theta}{2g} = \frac{2u_y}{g}$$

So all three particles have the same time period

Range ( $R$ ) is maximum for  $C$

$R$  = horizontal component of velocity  $\times T$

So, horizontal component of velocity is greater for  $C$

$$u = \sqrt{u_x^2 + u_y^2}$$

$u_x$  is least for  $A$  and  $u_y$  are same for all, so  $u$  is least for  $A$

297 (b)

Initial velocity  $\vec{u} = u \cos \theta \hat{i} + u \sin \theta \hat{j}$

$$\vec{u} = 60 \frac{\sqrt{3}}{2} \hat{i} + 60 \left(\frac{1}{2}\right) \hat{j} = 30\sqrt{3} \hat{i} + 30 \hat{j}$$

Velocity after 3s

$$\begin{aligned} \vec{v} &= u \cos \theta \hat{i} + (u \sin \theta - gt) \hat{j} \\ &= 30\sqrt{3} \hat{i} (30 - 10 \times 3) \hat{j} = 30\sqrt{3} \hat{i} \end{aligned}$$

Displacement after 2 s:

$$\begin{aligned} \vec{s} &= u \cos \theta t \hat{i} + \left(u \sin \theta t - \frac{1}{2} gt^2\right) \hat{j} \\ &= 30\sqrt{3} \times 2 \hat{i} + \left(30 \times 2 - \frac{1}{2} \times 10 \times (2)^2\right) \hat{j} \\ &= 60\sqrt{3} \hat{i} + 40 \hat{j} \end{aligned}$$

Velocity after 2 s  $\vec{v} = u \cos \theta \hat{i} + (u \sin \theta - gt) \hat{j}$

$$= 30\sqrt{3} \hat{i} + (30 - 10 \times 2) \hat{j} = 30\sqrt{3} \hat{i} + 10 \hat{j}$$

298 (a)

1. Area of  $v - t$  graph lies below time axis, so displacement is negative, but slope is positive, so acceleration is positive

2. Area of  $v - t$  graph lies above time axis, so displacement is positive, and slope is positive, so acceleration is also positive

3. Displacement is zero, because half area is above time axis and half below. Slope is negative, so acceleration is negative

4. Area of  $v - t$  lies above time axis, so displacement is positive, and slope is negative, so acceleration is also negative

299 (b)

5. In uniform circular motion, acceleration and velocity are perpendicular to each other, but in non-uniform circular motion, angle between velocity and acceleration lies between zero and  $\pi/2$

6. In straight line motion, acceleration vector and velocity vector are collinear to each other, i.e., angle between them is either zero or  $180^\circ$

7. In projectile motion, angle  $\theta$  between velocity and acceleration can vary from  $0 < \theta < \pi$

8. In space, angle between velocity and acceleration may be  $0 \leq \theta \leq \pi$

300 (a)

Slope of velocity-time graph gives acceleration. If the directions of acceleration and velocity are the same, then particle is speeding up, otherwise slowing down

Particle moves in the direction of velocity

301 (b)

If initial velocity and acceleration are in opposite directions, velocity reaches zero and then increases in the opposite direction

In (ii), initial velocity and acceleration are in the same direction, so velocity increases continuously and particle moves along the direction of acceleration



In (iii),  $x > 0$  but velocity can be either along positive or negative  $x$ -axis. Similarly in (iv)

302 (c)

Particle is accelerating when both velocity and acceleration are having the same direction (sign), and acceleration when velocity and acceleration have opposite direction (sign)

303 (a)

Distance will be minimum because man will reach from  $A$  to  $B$  directly

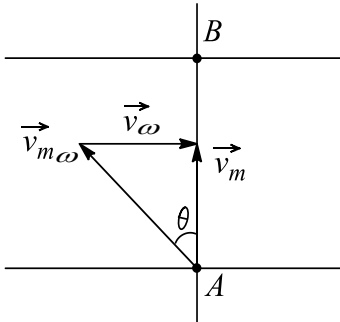

$$\sin \theta = \frac{v_{\omega}}{v_{m\omega}} \text{ and } \vec{v}_m \perp \vec{v}_{\omega}$$

Hence **i**  $\rightarrow$  **b,d**

Time taken is minimum if  $\vec{v}_{m\omega}$  is perpendicular to  $\vec{v}_{\omega}$

Hence **ii**  $\rightarrow$  **c, iv**  $\rightarrow$  **c**

If  $\vec{v}_{m\omega} < \vec{v}_{\omega}$ , then drift or distance is shortest if

$$\sin \theta = \frac{v_{m\omega}}{v_{\omega}}. \text{ Hence (iii) } \rightarrow \text{ a}$$

304 (c)

$$\text{When } v_L = \sqrt{5gr}, v_H = \sqrt{gr} = \sqrt{9.8 \times 1} = 3.13$$

305 (b)

To avoid skidding on unbanked curve,

$$v = \sqrt{\mu rg} = \sqrt{0.2 \times 200 \times 9.8} = 19.8 \text{ ms}^{-1}$$

306 (a)

$$\text{From figure } \tan \beta = \frac{AC}{OA} = \frac{5}{10} = \frac{1}{2}$$

So  $\beta = \tan^{-1}\left(\frac{1}{2}\right)$  West of North

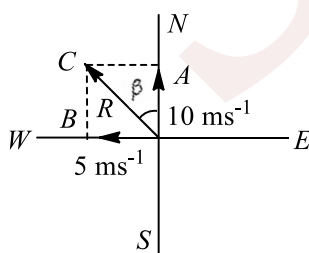

307 (b)

Both  $A$  and  $R$  are true and  $R$  is the correct explanation of  $A$

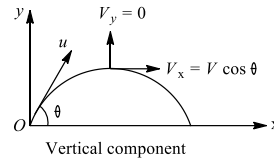

$$v_y = 0$$

$$\text{Horizontal component } v_x = v \cos \theta$$

308 (d)

Assertion is true but reason is false.

Horizontal range is same whether the body is projected at  $\theta = \theta_0$  or  $90 - \theta_0$

$$\text{But height } h = \frac{u^2 \sin^2 \theta}{2g}$$

Depends on sine of angle of projection, which is more for large angle ( $60^\circ$ ) and less for smaller one ( $30^\circ$ )

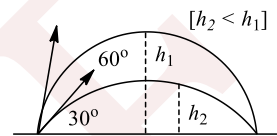

309 (d)

$QA$  represents velocity of man due east

$OQ$  represents relative velocity of rain w.r.t. man.

Actual velocity of rain is represented by  $QR$  fig

$$OR = \sqrt{OQ^2 + RQ^2} = \sqrt{3^2 + 3^2} = 3\sqrt{2} \text{ kmh}^{-1}$$

$$\text{Also, } \tan \theta = \frac{QR}{OQ} = 1 \Rightarrow \theta = 45^\circ$$

The rain is falling at  $45^\circ$  east of vertical with a velocity  $3\sqrt{2} \text{ kmh}^{-1}$

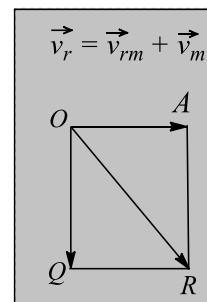

310 (c)

Taking  $N$  as  $+y$ -axis and  $E$  as  $+x$  Axis

Imagine yourself as an observer sitting inside the car. You will regard the car as being at rest (at  $C$ ).

Relative to you, the speed of the motorcyclist is obtained by imposing the reversed velocity of the car on motorcyclist as shown in Fig.  $v_m =$

$$15 \text{ ms}^{-1}, v_c = 20 \text{ ms}^{-1}$$



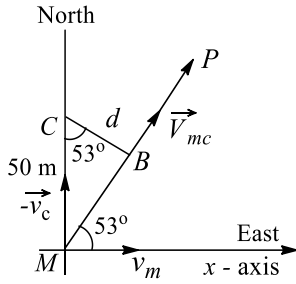

View from inside the car (at C)

$$v_{mc} = \sqrt{15^2 + 20^2} = 25 \text{ ms}^{-1}$$

$$\theta = \tan^{-1}\left(\frac{20}{15}\right) = 53^\circ \text{ with } x\text{-axis}$$

The motorcyclist appears to move along the line MP with speed  $25 \text{ ms}^{-1}$

The shortest distance = perpendicular distance of MP from C =  $d \Rightarrow d = 50 \cos 53^\circ \Rightarrow d = 30 \text{ m}$

Time taken to come closest = time taken by motorcyclist to reach B

$$t = \frac{MB}{v_{mc}} = \frac{50 \sin 53^\circ}{25} \Rightarrow t = 1.6 \text{ s}$$

311 (c)

$$t = \frac{d}{v \sin \theta} = \frac{0.5 \text{ km}}{3 \sin 120^\circ \text{ km h}^{-1}} = \frac{1}{3\sqrt{3}} \text{ h}$$

$$x = (u + v \cos \theta)t = (2 + 3 \cos 120^\circ) \frac{1}{3\sqrt{3}} = \frac{1}{6\sqrt{3}}$$

312 (b)

$$\sin 30^\circ = \frac{v_m}{v_r} \Rightarrow v_r = 1 \text{ ms}^{-1}$$

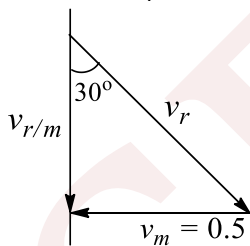

$$v_{r/m} = v_r \cos 30^\circ \times \frac{\sqrt{3}}{2} = 0.5 \sqrt{3} \text{ ms}^{-1}$$

313 (c)

Velocity of first body at any instant  $t$ ,  $\vec{v}_1 = 2\hat{i} - gt\hat{j}$

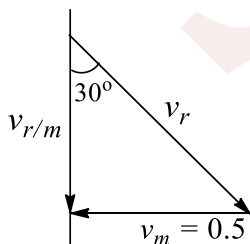

Velocity of second body at any instant

$$\vec{v}_2 = -8\hat{i} - gt\hat{j}$$

Since  $\vec{v}_1 \perp \vec{v}_2$ , i.e.,  $\vec{v}_1 \cdot \vec{v}_2 = 0$

$$(2\hat{i} - gt\hat{j}) \cdot (-8\hat{i} - gt\hat{j}) = 0 \Rightarrow -16 + g^2 t^2 = 0$$

$$\Rightarrow t = \sqrt{\frac{16}{g^2}} \Rightarrow t = \frac{4}{10} = 0.4 \text{ s}$$

$$\vec{S}_1 = (2 \times 0.4)\hat{i}, \vec{S}_2 = (8 \times 0.4)(-\hat{i})$$

$$\vec{S}_1 = 0.8\hat{i} \text{ and } \vec{S}_2 = -3.2\hat{i}$$

$$\text{Separation} = \vec{S}_1 - (-\vec{S}_2) = 0.8\hat{i} + (3.2\hat{i}) = 4\hat{i}$$

$$\vec{S}_1 = 2t\hat{i} - \frac{1}{2}gt^2\hat{j}, \vec{S}_2 = -8t\hat{i} - \frac{1}{2}gt^2\hat{j}$$

$$\text{As } \vec{S}_1 \perp \vec{S}_2 \text{ i.e., } \vec{S}_1 \cdot \vec{S}_2 = 0$$

$$-16t + \frac{1}{2} \times \frac{1}{2} g^2 t^4 = 0 \Rightarrow g^2 t^2 = 16 \times 4$$

$$\Rightarrow gt = 4 \times 2 \Rightarrow t = \frac{8}{10} = 0.8 \text{ s}$$

314 (d)

$$\vec{S} = \vec{u}t + \frac{1}{2}\vec{a}t^2$$

$$x\hat{i} + y\hat{j} = (5\hat{i})t + \frac{1}{2}(3\hat{i} + 2\hat{j})t^2$$

$$x = 5t + \frac{3}{2}t^2 \Rightarrow 84 = 5t + \frac{3}{2}t^2$$

$$\Rightarrow 3t^2 + 10t - 168 = 0$$

$$\Rightarrow 3t^2 + 28t - 18t - 168 = 0$$

$$\Rightarrow [3t + 28] - 6[3t + 28] = 0 \Rightarrow t = 6 \text{ s}$$

$$y = t^2 \Rightarrow y = 6^2 = 36 \text{ m}$$

315 (c)

Here  $r$  will become range

$$r = \frac{u^2 \sin 2\theta}{g} \Rightarrow gr = u^2 \sin 2\theta$$

$$h = u \sin \theta t + \frac{1}{2}gt^2 \text{ fig}$$

$$x = u \cos \theta t$$

$$t = \frac{x}{u \cos \theta}$$

$$h = u \sin \theta \frac{x}{u \cos \theta} + \frac{1}{2}g \frac{x^2}{u^2 \cos^2 \theta}$$

$$gx^2 + 2u^2 \sin \theta \cos \theta x - 2hu^2 \cos^2 \theta = 0$$

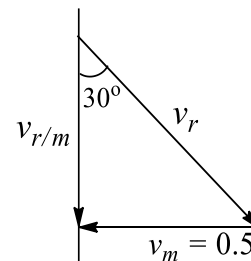

$$x = \frac{u \cos \theta}{g} \left[ \sqrt{u^2 \sin^2 \theta + 2gh} - u \sin \theta \right]$$

316 (a)



$$\frac{1}{2}mv^2 = mg(3-1) = 2mg \quad [\text{from conservation of energy}]$$

$$\text{or } v = \sqrt{4g} = 2\sqrt{g}$$

$$\text{Vertical component at A is } 2\sqrt{g} \sin 30^\circ = \sqrt{g}$$

Time of flight

$$T = \frac{2v \sin \theta}{g} = \frac{2\sqrt{g}}{g} = \frac{2}{\sqrt{g}}$$

Using  $S = ut + \frac{1}{2}at^2$ , we get

$$-1 = \sqrt{g}t - \frac{1}{2}gt^2 \text{ or } \frac{1}{2}gt^2 - \sqrt{g}t - 1 = 0$$

$$t = \frac{\sqrt{g} \pm \sqrt{g + 4 \times \frac{1}{2}g}}{2 \times \frac{g}{2}} = \frac{1 \pm \sqrt{3}}{\sqrt{g}}$$

Neglecting negative time,  $t = \frac{1+\sqrt{3}}{\sqrt{g}}$

$$x = 2\sqrt{g} \cos 30^\circ \left[ \frac{1+\sqrt{3}}{\sqrt{g}} \right] \text{ or } x = (\sqrt{3} + 3)m$$

317 (c)

$$h = v \sin \theta t - \frac{1}{2}gt^2 \text{ or } \frac{1}{2}gt^2 - v \sin \theta t + h = 0$$

$$t_1 + t_2 = -\frac{-v \sin \theta}{\frac{1}{2}g} = \frac{2v \sin \theta}{g} = T$$

$$\text{or } T = (1+3)s = 4s$$

$$h_{\max} = \frac{v^2 \sin^2 \theta}{2g}$$

$$= \frac{g^2 T^2}{8g} = \frac{1}{8}gT^2 = \frac{1}{8}g \times 4 \times 4$$

$$= 2g \left[ \because v \sin \theta = \frac{gT}{2} \right]$$

$$h = v \sin \theta t - \frac{1}{2}gt^2$$

$$\text{When } t = 1 \text{ s, then } h = v \sin \theta - \frac{1}{2}g$$

$$\text{or } h = \frac{g \times 4}{2} - \frac{g}{2} = 2g - \frac{g}{2} \text{ or } h = \frac{3g}{2}$$

$$\text{Aliter } \frac{1}{2}gt^2 - v \sin \theta t + h = 0$$

$$t_1 t_2 = \frac{h}{\frac{1}{2}g} \text{ or } 1 \times 3 = \frac{h}{g/2} \text{ or } h = \frac{3g}{2}$$

318 (c)

$$v_y^2 v_y^2 - v^2 \sin^2 \theta = -2g \left[ \frac{1}{2} \frac{v^2 \sin^2 \theta}{2g} \right]$$

$$\text{or } v_y^2 = v^2 \sin^2 \theta - \frac{v^2 \sin^2 \theta}{2} = \frac{v^2 \sin^2 \theta}{2}$$

$$\text{or } v_y = \frac{v \sin \theta}{\sqrt{2}}$$

$$v'^2 = (v \cos \theta)^2 + \left( \frac{v \sin \theta}{\sqrt{2}} \right)^2$$

$$= v^2 \cos^2 \theta + \frac{v^2 \sin^2 \theta}{2}$$

$$= v^2 \left( \cos^2 \theta + \frac{\sin^2 \theta}{2} \right)$$

$$v'' = v \sqrt{\cos^2 \theta + \frac{\sin^2 \theta}{2}}$$

$$v^2 \cos^2 \theta = \frac{2}{5} v^2 \left[ \cos^2 \theta + \frac{\sin^2 \theta}{2} \right]$$

$$\text{or } 5 \cos^2 \theta = 2 \cos^2 \theta + \sin^2 \theta \text{ or } 3 \cos^2 \theta = \sin^2 \theta$$

$$\text{or } \tan^2 \theta = 3 \text{ or } \tan \theta = \sqrt{3} \text{ or } \theta = 60^\circ$$

Angle of projection with vertical is  $90^\circ - 60^\circ = 30^\circ$

319 (c)

$$R = ut = u \sqrt{\frac{2h}{g}} = 3 \sqrt{\frac{2 \times 1}{10}} = \frac{3}{\sqrt{5}} \text{ m}$$

$$v_x = u_x = 3 \text{ ms}^{-1}$$

$$v_y^2 = u_y^2 + 2gh = 0^2 + 2 \times 10 \times 1 = 20$$

$$v = \sqrt{v_x^2 + u_y^2} = \sqrt{29} \text{ ms}^{-1}$$

320 (d)

$$y = x \tan \theta - \frac{gx^2}{2u^2 \cos^2 \theta}$$

$$\Rightarrow 15 = 30 \tan 45^\circ - \frac{10(30)^2}{2u^2 \cos^2 45^\circ} \Rightarrow u = 10\sqrt{6} \text{ ms}^{-1}$$

$$v_x = u_x = 10\sqrt{6} \cos 45^\circ = 10\sqrt{3} \text{ ms}^{-1}$$

$$v_y^2 = u_y^2 + 2a_y s_y = (10\sqrt{6} \sin 45^\circ)^2 + 2(-10)15 = 0$$

So velocity is  $10\sqrt{3} \text{ ms}^{-1}$  horizontally

321 (c)

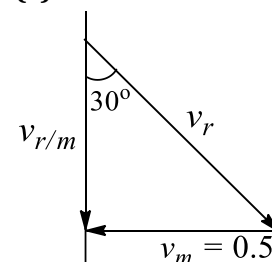

$$a_x = g \sin \theta, a_y = -g \cos \theta$$

$$S_y = 0 \Rightarrow u_y t + \frac{1}{2} a_y t^2 = 0$$

$$\Rightarrow v \sin \theta t - \frac{1}{2} g \cos \theta t^2 = 0$$

$$\Rightarrow t = \frac{2v \sin \theta}{g \cos \theta} = \frac{2 \times 5}{10} \tan \theta = \frac{3}{4} \text{ s}$$



$$R = u_x t + \frac{1}{2} a_x t^2 = v \cos \theta t + \frac{1}{2} g \sin \theta t^2$$

$$= 5 \cos 37^\circ \times \frac{3}{4} + \frac{1}{2} \times 10 \times \sin 37^\circ \times \left(\frac{3}{4}\right)^2 = \frac{75}{16} \text{ m}$$

$$v_x = u_x + a_x t = 5 \cos 37^\circ + g \sin 37^\circ \times \frac{3}{4}$$

$$= \frac{17}{2} \text{ ms}^{-1}$$

$$v_y = u_y + a_y t = 5 \sin 37^\circ - g \cos 37^\circ \times \frac{3}{4}$$

$$= -3 \text{ ms}^{-1}$$

$$v = \sqrt{v_x^2 + v_y^2} = \sqrt{\left(\frac{17}{2}\right)^2 + 3^2} = \frac{5}{2} \sqrt{13} \text{ ms}^{-1}$$

322 (c)

We know that  $a_c = \frac{v^2}{r} \Rightarrow r = \frac{v^2}{a_c}$ , where  $r$  is known as radius of curvature. At the highest point  $v = u \cos \theta$ ,  $a_c = g \Rightarrow r = \frac{u^2 \cos^2 \theta}{g}$

Similarly, find the velocity and  $a_c$  at the given point and then find  $r$ .  $a_c$  will be component of  $g$  perpendicular to velocity at that point fig

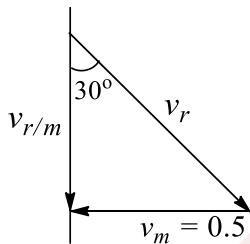

$$v \cos(\theta/2) = u \cos \theta \Rightarrow v = u \cos \theta \sec(\theta/2)$$

$$a_c = g \cos(\theta/2)$$

$$\text{Now find } r = \frac{v^2}{a_c}$$

$$h = H/2, v \cos \phi = u \cos \theta \quad \dots(i)$$

$$v^2 \sin^2 \phi = u^2 \sin^2 \theta - 2g \frac{H}{2} \quad \dots(ii)$$

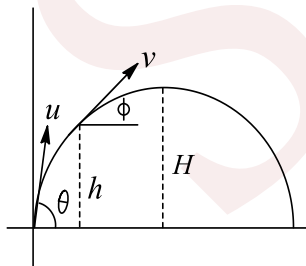

Squaring (i) and adding in (ii), we get

$$v^2 = u^2 - gH \text{ where } H = \frac{u^2 \sin^2 \theta}{2g}$$

$$a_c = g \cos \phi = \frac{gu \cos \theta}{v}$$

$$\text{Now } r = \frac{v^2}{a_c}$$

323 (a)

$$h = \frac{1}{2} g t^2$$

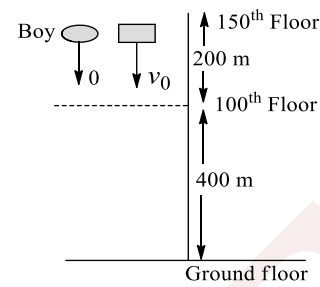

$$200 = \frac{1}{2} g \times (6.39)^2$$

$$\Rightarrow g = 9.798 = 9.80 \text{ ms}^{-2}$$

324 (a)

Initial velocity of ball w.r.t. ground

$$\vec{v}_{BG} = \vec{v}_{BE} + \vec{v}_{EG} = 15 + 10 = 25 \text{ ms}^{-1} \uparrow$$

$$\vec{v}_{BE} = 15 \text{ ms}^{-1} \uparrow, \vec{a}_{BG} = 10 \text{ ms}^{-2} \downarrow$$

$$\vec{a}_{BE} = \vec{a}_{BG} - \vec{a}_{EG} = 10 - (-5) = 15 \text{ ms}^{-2} \downarrow$$

$$\vec{s}_{BE} = 2 \text{ m} \downarrow. \text{ Using } s = ut + \frac{1}{2} at^2$$

w.r.t. elevator frame

$$-2 = 15t - \frac{1}{2} \times 15^2 \Rightarrow t = 2.13 \text{ s}$$

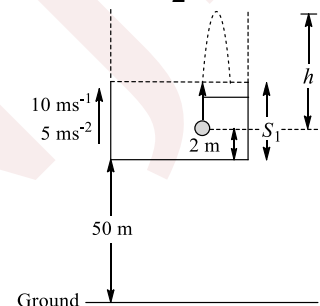

325 (a)

$$\text{Average velocity} = \frac{\text{Displacement}}{\text{Time}} = \frac{r\sqrt{2}}{t}$$

$$\text{Where } t = \frac{2\pi r/4}{v}$$

326 (b)

$$y = ax - bx^2$$

$$\text{or } \frac{dy}{dt} = a \frac{dx}{dt} - 2bx \frac{dx}{dt} = (a - 2bx) \frac{dx}{dt}$$

$$\text{Initially } x = 0, v_y = av_x$$

$$\frac{d^2y}{dt^2} = (a - 2bx) \frac{d^2x}{dt^2} + \left[-2b \frac{dx}{dt}\right]$$

$$= (a - 2bx) \frac{d^2y}{dt^2} - 2b \left(\frac{dx}{dt}\right)^2$$

$$\text{At } t = 0, \frac{d^2y}{dt^2} = -\alpha, x = 0, \frac{d^2x}{dt^2} = 0$$

$$\Rightarrow -\alpha = -2b \left(\frac{dx}{dt}\right)^2 = -2b(v_x)^2 \text{ or } v_x = \sqrt{\frac{\alpha}{2b}}$$



$$\Rightarrow v = \sqrt{v_x^2 + v_y^2} = v_x \sqrt{1 + a^2} = \sqrt{\frac{\alpha(1 + a^2)}{2b}}$$

327 (b)

$$x = a \sin \omega t, y = a - a \cos \omega t$$

$$v_x = \frac{dx}{dt} = a\omega \cos \omega t, v_y = \frac{dy}{dt} = a\omega \sin \omega t$$

$$\text{Now } v = \sqrt{v_x^2 + v_y^2} = a\omega$$

328 (d)

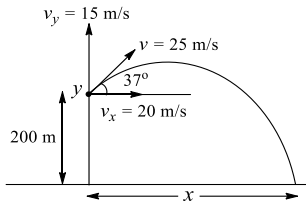

$$s_y = v_y t - \frac{1}{2}gt^2 \Rightarrow -200 = 15t - 5t^2 \Rightarrow t = 8 \text{ sec}$$

$$x = v_x t = 20 \times 8 = 160 \text{ m}$$

329 (d)

$$v = u + at = (2\hat{i} - 9\hat{j}) + (4\hat{i} + 3\hat{j}) \times 2 = 10\hat{i} - 3\hat{j}$$

330 (a)

$$V_{B,A} = V_B - V_A$$

$$= -14 \cos 45^\circ \hat{i} + 14 \sin 45^\circ \hat{j} - (2 \cos 45^\circ \hat{i} - 2 \sin 45^\circ \hat{j})$$

$$= -\frac{16}{\sqrt{2}} \hat{i} + \frac{12}{\sqrt{2}} \hat{j} = -8\sqrt{2} \hat{i} + 6\sqrt{2} \hat{j}$$

331 (d)

Two given planes are mutually perpendicular and the particle is projected perpendicularly from plane  $OA$ . It means  $\vec{u}$  is parallel to plane  $OB$

At the instant of collision of the particle with  $OB$ , its velocity is perpendicular to  $OB$  or velocity component parallel to  $OB$  is zero

First considering motion of particle parallel to plane  $OB$ ,  $u = 10\sqrt{3} \text{ ms}^{-1}$ , acceleration =  $-g \sin 60^\circ = -5\sqrt{3} \text{ ms}^{-2}$

$$v = 0, t = ? s = ?$$

$$\text{Using } v = u + at \Rightarrow 0 = 10\sqrt{3} - 5\sqrt{3}t \Rightarrow t = 2 \text{ s}$$

$$s = ut + \frac{1}{2}at^2 \Rightarrow OQ = 10\sqrt{3} \times 2 - \frac{1}{2}5\sqrt{3}(2)^2$$

$$\Rightarrow OQ = 10\sqrt{3} \text{ m}$$

Now considering motion of the particle normal to plane  $OB$ . Initial, velocity = 0, acceleration =  $g \cos 60^\circ = 5 \text{ ms}^{-2}$

$$v = ? s = PO = ?$$

$$\text{Using } v = u + at,$$

$$\text{We get } v = 10 \text{ ms}^{-1}$$

$$s = ut + \frac{1}{2}at^2 \text{ or } PO = 10 \text{ m}$$

$$h = PO \sin 30^\circ = 10 \times \sin 30^\circ = 5 \text{ m}$$

Inclination of velocity at point  $P$  with the vertical is  $30^\circ$ , therefore its vertical component is,

$$u \cos 30^\circ = 15 \text{ ms}^{-1} \text{ (upward)}$$

Considering vertically upward motion of the particle from  $P$ , initial velocity =  $15 \text{ ms}^{-1}$

$$\text{Acceleration} = -g = -10 \text{ ms}^{-2}, v = 0, s = H = ?$$

$$\text{Using } v^2 = u^2 + 2as, \text{ we get } H = 11.25 \text{ m}$$

Maximum height reached by particle above  $O$  is

$$h + H = 16.25 \text{ m}$$

$$\text{Distance } PQ = \sqrt{(PO)^2 + (OQ)^2}$$

$$= \sqrt{(10)^2 + (10\sqrt{3})^2} = 20 \text{ m}$$

332 (b)

Since the  $x - t$  graph is parabolic, its slope (velocity) should change linearly. At  $t = 0$ , slope is positive, so velocity should be positive. At  $t = T$ , slope is zero, so velocity should be zero. At  $t = 2T$ , slope is negative, so velocity should be negative

333 (b)

$$a = 5t \Rightarrow \frac{dv_y}{dt} = 5t \Rightarrow v_y = \frac{5t^2}{2}$$

$$\Rightarrow \frac{dy}{dt} = \frac{5}{2}t^2 \Rightarrow y = \frac{5}{6}t^3$$

$$\text{Putting } y = d, \text{ we get } d = \frac{5}{2}t^3 \Rightarrow t = \left(\frac{6d}{5}\right)^{1/3}$$

334 (2)

$$AB = 2R \cos \theta$$

$$AB = \frac{1}{2}g \cos \theta t^2 \Rightarrow 2R \cos \theta = \frac{1}{2}g \cos \theta t^2$$

$$2\sqrt{\frac{R}{g}} = t \Rightarrow 2\sqrt{\frac{10}{10}} = t = 2 \text{ s}$$

335 (2)

$$y = u \sin \theta t - \frac{1}{2}gt^2$$

$$15 = 52 \times \frac{5}{13}t - \frac{1}{2} \times 10t^2$$

$$5t^2 + -20t + 15 = 0$$

$$t^2 - 4t + 3 = 0$$

$$t^2 - 3t \times t + 3 = 0 \Rightarrow t(t - 3) - 1(t - 3) = 0$$

$$t_1 = 1 \text{ s} \Rightarrow t_2 = 3 \text{ s}$$

$$\text{Thus, } t_2 - t_1 = 3 - 1 = 2 \text{ s}$$

336 (4)

$$\text{Initial velocity } u = u \cos \theta \hat{i} + u \sin \theta \hat{j}$$

$$\text{Velocity after time } t \text{ is}$$



$$v = u \cos \theta \hat{i} + (u \sin \theta - gt) \hat{j}$$

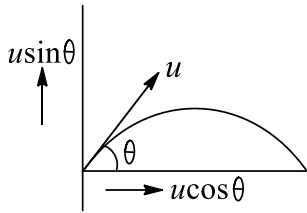

Since  $u$  and  $v$  are perpendicular to each other

$$\vec{u} \cdot \vec{v} = 0$$

$$(u \cos \theta \hat{i} + u \sin \theta \hat{j}) \times [u \cos \theta \hat{i} + (u \sin \theta - gt) \hat{j}] = 0$$

$$u^2 \cos^2 \theta + u^2 \sin^2 \theta - u \sin \theta gt = 0$$

$$t = \frac{u}{g \sin \theta} = \frac{20}{10 \times \frac{1}{2}} = 4s$$

337 (5)

At any instant  $t$ , the distance of the particles  $P$  and  $Q$  from  $O$  are  $(\ell_1 - v_1 t)$  and  $(\ell_2 - v_2 t)$ , respectively

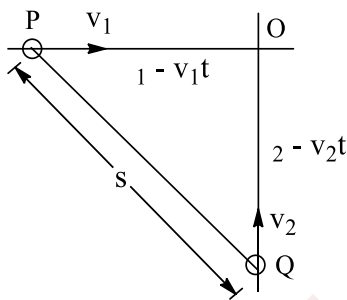

$$s = PQ = \sqrt{(\ell_1 - v_1 t)^2 + (\ell_2 - v_2 t)^2}$$

For minimum  $s$

$$\frac{ds}{dt} = 0 \text{ and } \frac{d^2s}{dt^2} > 0$$

$$2s \frac{ds}{dt} = 2(\ell_1 - v_1 t)(-v_1) + 2(\ell_2 - v_2 t)(-v_2) = 0$$

$$t = \frac{\ell_1 v_1 + \ell_2 v_2}{v_1^2 + v_2^2} = 5s$$

$$s_{\min} = \frac{\ell_1 v_2 + \ell_2 v_1}{\sqrt{v_1^2 + v_2^2}} = 2.237 \gg 2 \text{ m}$$

338 (4)

$$v_{av} = \frac{r\sqrt{2}}{T/4}$$

$$= \frac{r\sqrt{2} \times 4v}{2\pi r} = \frac{2\sqrt{2}v}{\pi} = \frac{2\sqrt{2}(\sqrt{2}\pi)}{\pi} = 4 \text{ m/s}$$

339 (9)

$$v_x = v \cos 60^\circ = 2\sqrt{15} \text{ m/s}$$

$$\therefore v = 4\sqrt{15} \text{ m/s}$$

$$\therefore v_y = v \sin 60^\circ = 4\sqrt{15} \frac{\sqrt{3}}{2} = 2\sqrt{45} \text{ m/s}$$

$$H_{\max} = \frac{v_y^2}{2g} = \frac{4 \times 45}{20} = 9 \text{ m}$$

340 (5)

As the velocity of the ball changes from  $\vec{v}_1$  to  $\vec{v}_2$ , the change in velocity  $\Delta\vec{v}$  is given by

$$|\Delta\vec{v}| = \sqrt{v_1^2 + v_2^2 - 2v_1v_2 \cos \theta}$$

Where  $v_1 = 30 \text{ m/s}$ ,  $v_2 = 40 \text{ m/s}$  and  $\theta = 90^\circ$ .

Then,  $|\Delta\vec{v}| = 5 \text{ m/s}$

$$a_{av} = \frac{|\Delta\vec{v}|}{\Delta t} = \frac{5}{0.01} = 5 \times 10^2 \text{ m/s}^2$$

341 (2)

At minimum velocity, it will move just touching point  $E$  reaching the ground  $A$  is origin of reference co-ordinate

If  $u$  is the minimum speed,  $x = 40$ ,  $y = 20$ ,  $\theta = 0^\circ$

$$y = x \tan \theta - g \frac{x^2 \sec^2 \theta}{2u^2}$$

Where  $g = 10 \text{ ms}^{-2} = 1000 \text{ cm s}^{-2}$

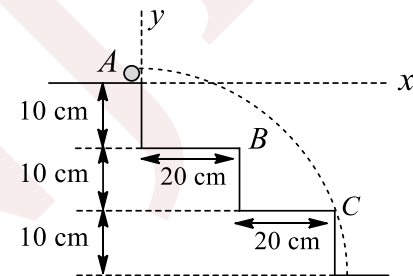

$$-20 = -\frac{800000}{2u^2}$$

$$u = 200 \text{ cm s}^{-1} = 2 \text{ ms}^{-1}$$

342 (5)

$$T = \frac{2u \sin \theta}{g} \Rightarrow T = \frac{2 \times 10 \times \sqrt{3}}{10 \times 2} = \sqrt{3} \text{ sec}$$

$$R = u \cos \theta \cdot T - \frac{1}{2} a T^2$$

$$1.15 = 10 \times \frac{1}{2} \sqrt{3} - \frac{1}{2} \sqrt{3} - \frac{1}{2} a (\sqrt{3})^2$$

$$\frac{3}{2} a = 5\sqrt{3} - 1.15$$

$$\frac{3a}{2} = 8.65 - 1.15 = 7.5$$

$$a = 7.5 \times \frac{2}{5} \approx \text{m/sec}^2$$

$$a = 5 \text{ m/sec}^2$$

343 (5)



$$v_x = \frac{dx}{dt} = 3 \text{ and } v_y = \frac{dy}{dt} = 4 - 10t = 4 - 10(0) = 4$$

$$v = [v_x^2 + v_y^2]^{1/2} = [3^2 + 4^2]^{1/2} = 5 \text{ m/sec}$$

344 (7)

At  $t = T/6$ , particle will travel only  $1/6$  of the circle

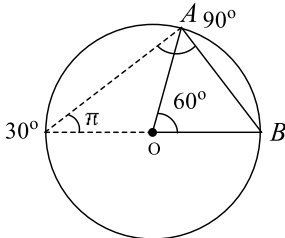

$$\text{Average speed} = \frac{\text{Arc } AB}{\text{Time}} = \frac{(2\pi R)/6}{T/6} = \frac{2\pi R}{T}$$

$$\text{Average velocity} = \frac{\text{Chord } AB}{\text{Time}} = \frac{2R \sin 30^\circ}{T/6} = \frac{6R}{T}$$

$$\text{Difference} = \frac{R}{T} \left[ \frac{44}{7} - 6 \right] = \frac{22}{7T} = 2 \text{ ms}^{-1} \text{ (given)}$$

$$R = 7T = 7(1) = 7 \text{ m}$$

345 (3)

The horizontal and vertical components of the velocity are the same, let it be  $u = v \cos 45^\circ$

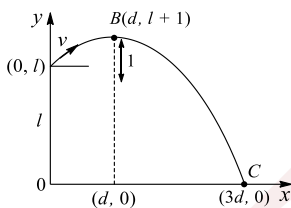

$$\text{From A to B: } 1 = \frac{u^2}{2g} \Rightarrow u^2 = 2g$$

$$\text{At B: } d = ut_1 \Rightarrow t_1 = d/u$$

$$1 = ut_1 - \frac{g}{2} t_1^2 = u \frac{d}{u} - \frac{g d^2}{2 u^2}$$

$$\Rightarrow 1 = d - \frac{g d^2}{2 u^2} \Rightarrow 1 = d - \frac{g d^2}{4g}$$

$$\Rightarrow 4 = 4d - d^2 \Rightarrow d^2 - 4d + 4 = 0$$

$$\Rightarrow d = 2 \text{ m}$$

$$\text{At C: } 3d = ut_2 \Rightarrow t_2 = \frac{3d}{u}$$

$$-l = ut_2 - \frac{1}{2} g t_2^2 = u \cdot \frac{3d}{u} - \frac{g 9d^2}{2 \cdot 4^2} = 3d - \frac{9gd^2}{4g}$$

$$= 3d - \frac{9d^2}{4} = 3 \times 2 - \frac{9}{4} \times 4 = 6 - 9 = -3$$

$$\Rightarrow l = 3 \text{ m}$$

346 (0)

As  $s-t$  graph is a parabola, it can be given as  $s = k_1 t - k_2 t^2$ , where  $k_1$  and  $k_2$  are constants. Since it is symmetrical  $t = 1$  s, we have equal

displacements at  $t = \frac{1}{2}$  s and  $t = \frac{3}{2}$  s that tells us that line  $AB$  joining two coordinates is parallel to the  $t$ -axis. Hence, slope of  $AB$  is zero. This implies that the average velocity during the time interval  $\Delta t = 1$  s is zero

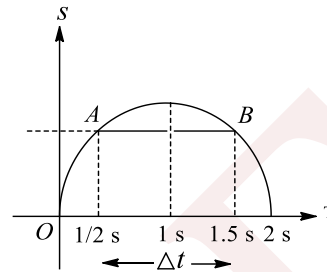

347 (3)

The velocity of the particle at  $t = 4$  s can be given as

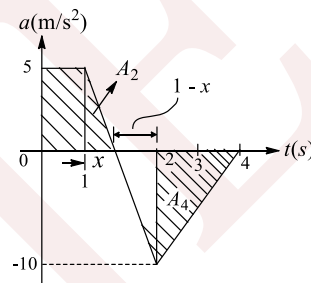

$$\vec{v}_4 = \vec{v}_0 + \Delta \vec{v} \quad \dots (i)$$

Where  $\Delta \vec{v} \equiv A$  (= area under  $a-t$  graph during first 4 s)

Referring to  $a-t$  graph (shown in the figure), we have

$$A = A_1 + A_2 - A_3 - A_4 \quad \dots (ii)$$

$$\text{Where } A_1 = 5 \times 1 = 5, A_2 = \frac{1}{2} \times x \times 5$$

$$A_3 = \frac{1}{2} \times (1-x) \times 10 \text{ and } A_4 = \frac{1}{2} \times 2 \times 10 = 10$$

We can find the value of  $x$  as follows:

$$\text{Using properties of similar triangles, we have } \frac{x}{5} = \frac{1-x}{10}$$

$$\text{This yields } x = \frac{1}{3}$$

$$\text{Substituting } x = \frac{1}{3} \text{ in } A_2 = \frac{1}{2} \times x \times 5 \text{ and } A_3 =$$

$$\frac{1}{2} (1-x) \times 10, \text{ we have}$$

$$A_2 = \frac{5}{6} \text{ and } A_3 = \frac{10}{3}$$

Then substituting  $A_1, A_2, A_3$  and  $A_4$  in Eq. (ii), we

$$\text{have } A = -7.5 \Rightarrow \Delta v = -7.5 \text{ and } \vec{v}_0 = 10.5 \text{ m/s}$$

$$\text{Hence, we have } v_4 = v_0 + \Delta v = 10.5 - 7.5 =$$

$$3 \text{ m/s}$$

348 (2)



$$80 = \frac{1}{2} \times 10$$

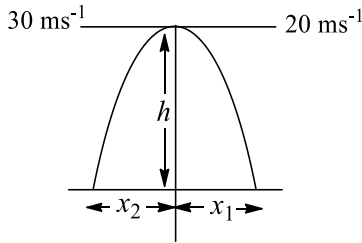

$$t^2 = \frac{80}{5} \Rightarrow t = 4$$

$$x_1 = 20 \times 4 = 120$$

$$x_2 = 30 \times 4 = 120$$

$$\text{Separation } x_1 + x_2 = 80 + 120 = 200 \text{ m}$$

349 (2)

Let the velocity of car be  $u$  when the ball is thrown. Initial velocity of car = Horizontal velocity of ball

Distance travelled by ball  $B$ ,  $S_b = ut$  (in horizontal direction)

$$\text{Car has travelled extra distance} = S_c = S_b = \frac{1}{2}at^2$$

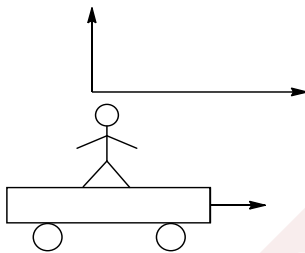

Ball can be considered a projectile having  $\theta = 90^\circ$

$$t = \frac{2u \sin \theta}{g} = \frac{2 \times 9.8}{9.8} = 2 \text{ s}$$

$$S_c - S_b = \frac{1}{2}at^2 = \frac{1}{2}(1)2^2 = 2 \text{ m}$$

Hence, the ball will drop 2 m behind the boy

350 (5)

$$v_x = u_x + a_x t \Rightarrow 0 = u \cos 30^\circ - g \sin 30^\circ t$$

$$\Rightarrow t = \frac{u \sqrt{3}}{g}$$

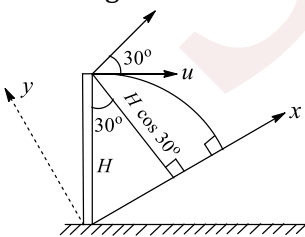

$$S_y = u_y t + \frac{1}{2}a_y t^2$$

$$\Rightarrow -H \cos 30^\circ = -u \sin 30^\circ t - \frac{1}{2}g \cos 30^\circ t^2$$

$$\Rightarrow -H \frac{\sqrt{3}}{2} = \frac{-u u \sqrt{3}}{2g} - \frac{1}{2}g \frac{\sqrt{3} u^2 3}{g^2}$$

$$\Rightarrow u = \sqrt{2gH/5} = \sqrt{2 \times 10 \times 6.25/5} = 5 \text{ m/s}$$

351 (6)

$$\text{Maximum range } (\theta = 45^\circ) = \frac{u^2}{g} = 0.8 u = 2\sqrt{2} \text{ m}$$

$$\text{Distance covered in } 3 \text{ s} = (u \cos 45^\circ)(3)$$

$$= (2\sqrt{2}) \left(\frac{1}{\sqrt{2}}\right) (3) = 6 \text{ m}$$

352 (9)

Radius of curvature at the highest point

$$r = \frac{v}{g} \Rightarrow r = \frac{(v_0 \cos \theta)^2}{g}$$

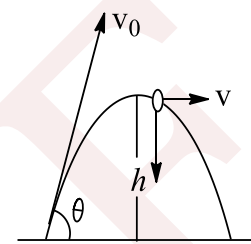

$$v_0 \cos \theta = \sqrt{gr} \dots (i)$$

$$\text{Maximum height } h = \frac{v_0^2 \sin^2 \theta}{g} \Rightarrow v_0 \sin \theta = \sqrt{gh}$$

... (ii)

By using (i) and (ii), we get

$$v_0^2 \sin^2 \theta + v_0^2 \cos^2 \theta = gh + gr = g(h + r)$$

$$\Rightarrow v_0 = \sqrt{g(h + r)} = \sqrt{10(5 + 3)} = 9 \text{ ms}^{-1}$$

353 (5)

Let the particle meet after at time  $t$ . First of all, we choose the point of collision above the top of the cliff

For the first particle,  $s = s_1, v_0 = v_1, a = -g$

$$\text{Then, } s_1 = v_1 t - \frac{1}{2}gt^2 \dots (i)$$

For the second particle,  $s = s_2, v_0 = v_2, a = -g$

$$\text{Then, } s_2 = v_2 t - \frac{1}{2}gt^2 \dots (ii)$$

Referring to the figure,  $s_2 - s_1 = h \dots (iii)$

Substituting  $s_1$  from Eq. (i),  $s_2$  from Eq. (ii) in Eq. (iii),

$$\text{We have } t = \frac{h}{v_2 - v_1} = \frac{10}{4 - 2} = 5 \text{ s}$$

354 (2)

$$(a) T = \frac{2u \sin(\alpha - \beta)}{g \cos \beta} \dots (i)$$

Now we shall consider the motion of particle along  $OA$



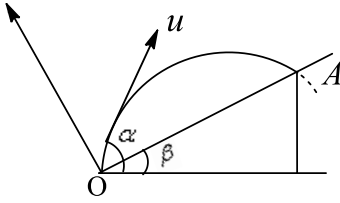

(b) When the particle strikes the plane horizontally

$$\text{In this case } t = \frac{2u \sin(\alpha - \beta)}{g \cos \beta}$$

$$\text{and } 0 = u \sin \alpha - gt$$

$$u \sin \alpha = g \left[ \frac{2u \sin(\alpha - \beta)}{g \cos \beta} \right]$$

$$2 \tan \beta = \tan \alpha \Rightarrow \tan \alpha : \tan \beta = 2$$

SENJEE

